

IFB#6-2014/2015 GULF COAST STATE COLLEGE PHASE 1 CAMPUS IMPROVEMENTS PANAMA CITY, FLORIDA

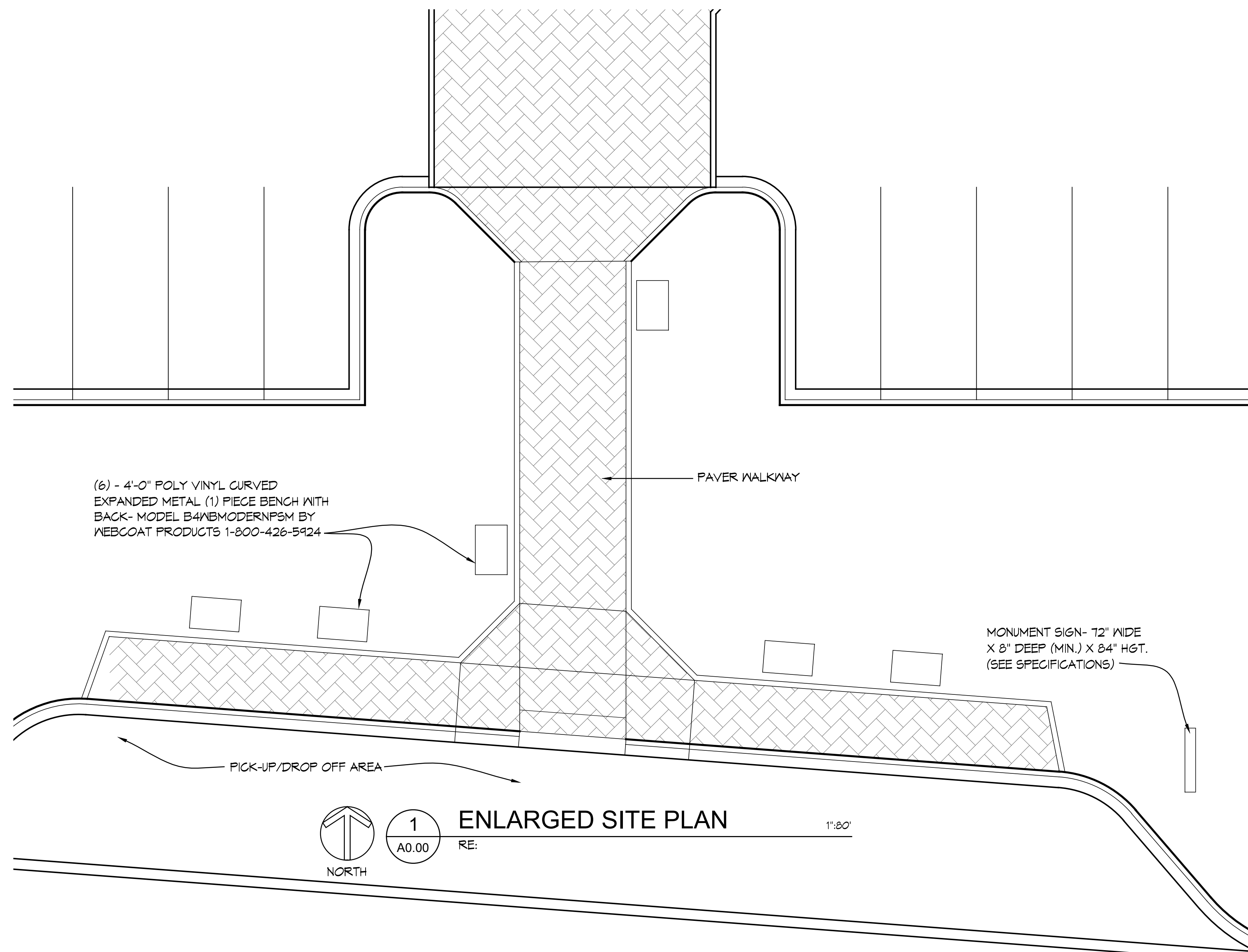

VICINITY MAP



ENLARGED SITE PLAN
 1
 A0.00 RE:
 NORTH
 1"=80'

DESIGN CODES	
FLORIDA BUILDING CODE (FBC)	2010 ED
FBC - PLUMBING CODE	2010 ED
FBC - ACCESSIBILITY CODE	2010 ED
NEC - NATIONAL ELECTRIC CODE	2008 ED
FLORIDA FIRE PREVENTION CODE	2010 ED
LIFE SAFETY CODE (NFPA 101)	2006 ED
AMERICANS WITH DISABILITIES ACT	2004 ED

PROJECT SUMMARY NOTES

- THE SCOPE OF WORK INDICATED ON THESE DRAWINGS IS FOR DEMOLITION OF EXISTING PARKING LOT AND CONSTRUCTION OF A NEW PARKING LOT TO INCLUDE, BUT NOT NECESSARILY LIMITED TO, THE FOLLOWING:
 - SITE WORK, TO INCLUDE; GRADING, UTILITY CONNECTIONS, INSTALLATION OF NEW WALKWAY, STORM WATER AND PARKING SPACE. (SITE DESIGN BY OTHERS)
 - NEW LANDSCAPING AND IRRIGATION.
 - NEW LIGHT POLES
- G.C. SHALL FIELD VERIFY ALL SIZES AND FIELD CONDITIONS PRIOR TO BEGINNING WORK.
- THE ARCHITECT/OWNER RESERVES THE RIGHT TO REJECT ITEMS INCORPORATED INTO THE WORK WHICH FAILED TO MEET THE SPECIFIED MINIMUM REQUIREMENTS. THE ARCHITECT/OWNER FURTHER RESERVES THE RIGHT AND WITHOUT PREJUDICE FOR OTHER RECOURSE SO THAT THE ARCHITECT/OWNER MAY MAKE ACCEPTABLE ANY NON-COMPLIANT ITEMS SUBJECT TO AN ADJUSTMENT IN THE CONTRACT AMOUNT AS APPROVED BY THE OWNER.

INDEX OF DRAWINGS	
GENERAL	
A0.00 COVER SHEET / DRAWINGS INDEX / VICINITY MAP	
CIVIL	
C1	GENERAL NOTES
C2	OVERALL SITE PLAN
C3	PROJECT LIMITS
C4	DEMOLITION AND EROSION CONTROL PLAN
C5	OVERALL SITE UTILITY PLAN
C6	SITE UTILITY PLAN
C7	SITE UTILITY PLAN
C8	SITE PAVING PLAN
C9	OVERALL SITE GRADING PLAN
C10	SITE GRADING PLAN
C11	SITE GRADING PLAN
C12	SITE GEOMETRY PLAN
C13	SITE GEOMETRY PLAN
C14	OVERALL SIGNAGE AND STRIPING PLAN
C15	SIGNAGE AND STRIPING PLAN
C16	SIGNAGE AND STRIPING PLAN
C17	STORMWATER POLLUTION PREVENTION PLAN
C18	STORMWATER POLLUTION PREVENTION PLAN DETAILS
C19	MISCELLANEOUS DETAILS
C20	MISCELLANEOUS DETAILS
LANDSCAPE	
L1.0	LANDSCAPE PLAN
L2.0	LANDSCAPE PLAN
L3.0	LANDSCAPE PLAN
L4.0	IRRIGATION PLAN
L5.0	IRRIGATION PLAN
L6.0	IRRIGATION PLAN
ELECTRICAL	
E1	ELECTRICAL LEGENDS
E2	ELECTRICAL DEMOLITION PLAN
E3	NEW WORK ELECTRICAL LIGHTING PLAN
E4	NEW WORK CCTV INFRASTRUCTURE PLAN
E5	LANGUAGE ARTS ELECTRICAL WORK PLAN
E6	ELECTRICAL DETAILS
E7	ELECTRICAL RISER AND CONCRETE POLE FOUNDATION DETAIL

GULF COAST STATE COLLEGE
 PHASE 1 CAMPUS
 IMPROVEMENTS
 TITLE SHEET,
 INDEX OF DRAWINGS,
 ENLARGED SITE PLAN

Copyright © 2015 BY FLORIDA ARCHITECTS, INC. ARCHITECT EXPRESSLY RESERVES HIS EXCLUSIVE COMMON LAW COPYRIGHT AND PROPERTY RIGHTS TO THESE DRAWINGS WHICH MAY NOT BE REPRODUCED, CHANGED OR COPIED IN ANY FORM OR MANNER, NOR ARE THEY TO BE ASSIGNED TO ANY PARTY WITHOUT THE ARCHITECT'S WRITTEN CONSENT.

GENERAL NOTES:

- THE BENCHMARK DATUM USED FOR THE PLANS IS NAVD88.
- ANY PUBLIC LAND CORNER OR MONUMENT THAT PERPETUATES BAY COUNTY RIGHT OF WAY WITHIN THE PROJECT LIMITS IS TO BE PROTECTED BY THE CONTRACTOR. IF A MONUMENT IS IN DANGER OF BEING DESTROYED THE CONTRACTOR IS TO ENSURE THAT IT IS PROPERLY REFERENCED AND RESET PRIOR TO PROJECT COMPLETION. THE MONUMENTS SET SHALL MEET MINIMUM TECHNICAL STANDARDS AS DEFINED IN 61G17, F.A.C. AND CURRENT BAY COUNTY SURVEYING STANDARDS.
- ALL WORK SHALL BE PERFORMED IN ACCORDANCE WITH FDOT 2013 DESIGN STANDARDS AND STANDARD SPECIFICATIONS FOR ROAD AND BRIDGE CONSTRUCTION, UNLESS OTHERWISE STATED OR SHOWN IN THE PLANS.
- ALL WORK SHALL BE PERFORMED IN ACCORDANCE WITH THE CITY OF PANAMA CITY STANDARDS AND SPECIFICATIONS, UNLESS APPROVED BY THE CITY OF PANAMA CITY.
- THE CONTRACTOR SHALL NOT BRING ANY HAZARDOUS MATERIALS ONTO THE PROJECT. SHOULD THE CONTRACTOR REQUIRE SUCH MATERIALS FOR PERFORMING THE CONTRACTED WORK, THE CONTRACTOR SHALL REQUEST, IN WRITING, WRITTEN PERMISSION FROM THE PROJECT ADMINISTRATOR. THE CONTRACTOR SHALL PROVIDE THE PROJECT ADMINISTRATOR WITH A COPY OF THE MATERIAL SAFETY DATA SHEET (MSDS) FOR EACH HAZARDOUS MATERIAL PROPOSED FOR USE. THE CONSTRUCTION PROJECT ADMINISTRATOR SHALL COORDINATE WITH THE ENGINEER OF RECORD PRIOR TO ISSUING WRITTEN APPROVAL TO THE CONTRACTOR. SINCE STATE LAW DOES NOT TREAT PETROLEUM PRODUCTS THAT ARE PROPERLY CONTAINERIZED AND INTENDED FOR EQUIPMENT USE AS A HAZARDOUS MATERIAL, SUCH PRODUCTS DO NOT NEED A MSDS SUBMITTAL.
- ANY KNOWN OR SUSPECTED HAZARDOUS MATERIAL FOUND ON THE PROJECT SHALL IMMEDIATELY BE REPORTED TO THE CONSTRUCTION PROJECT ADMINISTRATOR WHO SHALL DIRECT THE CONTRACTOR TO PROTECT THE AREA OF KNOWN OR SUSPECTED CONTAMINATION FROM FURTHER ACCESS. THE CONSTRUCTION PROJECT ADMINISTRATOR IS TO NOTIFY THE PROJECT MANAGER OF DISCOVERY. THE PROJECT MANAGER WILL ARRANGE AN INVESTIGATION, IDENTIFICATION AND REMEDIATION OF THE HAZARDOUS MATERIAL. THE CONTRACTOR SHALL NOT RETURN TO THE AREA OF CONTAMINATION UNTIL APPROVAL IS PROVIDED BY THE CONSTRUCTION PROJECT ADMINISTRATOR.
- THE CONTRACTOR SHALL NOTIFY UTILITY OWNERS THROUGH SUNSHINE ONE CALL OF FLORIDA, INC. TWO BUSINESS DAYS IN ADVANCE OF BEGINNING CONSTRUCTION ON THE JOB SITE. CALL 1-800-432-4770 AND 811 (NATIONWIDE TOLL FREE UTILITY LOCATE). THE LOCATION OF THE UTILITIES SHOWN ON THE PLANS ARE APPROXIMATE ONLY. THE EXACT LOCATION SHALL BE DETERMINED BY THE CONTRACTOR DURING CONSTRUCTION.
- INFORMATION SHOWN ON THE PLANS CONCERNING THE TYPE AND LOCATION OF UNDERGROUND AND OVERHEAD UTILITIES IS BASED ON DATA PROVIDED BY UTILITY OWNERS, AVAILABLE RECORDS, AND FIELD SURVEYS. THE PLANS MAY NOT SHOW ALL UTILITIES WITHIN PROJECT LIMITS, EITHER ACTIVE OR PLACED OUT-OF-SERVICE, OR THAT SAID UTILITIES ARE ACTUALLY IN THE HORIZONTAL OR VERTICAL POSITIONS SHOWN IN THE PLANS. DETERMINE THE TYPE AND LOCATION OF ALL UTILITIES TO ESTABLISH THEIR LOCATIONS AND TO AVOID DAMAGE TO UNDERGROUND UTILITIES.
- UTILITY ADJUSTMENTS ARE TO BE PERFORMED BY THE UTILITY OWNERS UNLESS OTHERWISE NOTED.
- SWEEPING SHALL OCCUR DAILY OR AFTER SUCH EVENTS AS CAUSE TRACKING ONTO STREET.
- ALL PROPOSED GROUND ELEVATIONS ARE FINISHED SOD ELEVATIONS. FINISH EARTHWORK GRADING SHALL BE 0.2 FEET BELOW ELEVATIONS SHOWN TO ALLOW FOR SOD THICKNESS.
- SODDING INCLUDES MAINTAINING SLOPES AND SOD UNTIL COMPLETION AND ACCEPTANCE OF TOTAL PROJECT OR GROWTH IS ESTABLISHED, WHICHEVER COMES LAST. UNTIL THEN, ALL EROSION, SILTATION AND MAINTENANCE OF GRADES IS THE RESPONSIBILITY OF THE CONTRACTOR.
- WHERE EXCAVATIONS ARE IN CLOSE PROXIMITY OF TREES NOT SHOWN AS BEING REMOVED, THE CONTRACTOR SHALL USE EXTREME CARE IN NOT DAMAGING THE ROOT SYSTEM, NO EQUIPMENT, SUPPLIES, OR VEHICLES SHALL BE STORED OR PARKED WITHIN THE DRIP LINE OF TREES TO REMAIN AND BE PRESERVED. IT SHALL BE THE RESPONSIBILITY OF THE CONTRACTOR TO INFORM ALL EMPLOYEES AND SUBCONTRACTORS OF THIS REQUIREMENT AND TO ENFORCE SAME.
- PROPOSED CONSTRUCTION SHALL COMPLY WITH THE AMERICANS WITH DISABILITIES ACT (ADA), THE ADA COMPLIANCE HANDBOOK, LATEST EDITION, AND THE FLORIDA ACCESSIBILITY CODE. SIDEWALK CONSTRUCTION AND EXPANSION JOINT SPACING SHALL BE IN ACCORDANCE WITH FDOT DESIGN STANDARD INDEX 310.
- ALL INLETS SHALL BE PROTECTED AS PER FDEP BEST MANAGEMENT PRACTICES, AND THE FDEP/FDOT EROSION AND SEDIMENT CONTROL HANDBOOK.
- THE CONTRACTOR SHALL PROTECT ALL GRASSED AREAS FROM DISCARDED CONCRETE AND EXCESS MATERIALS. ALL DISCARDED CONCRETE AND EXCESS MATERIALS SHALL BE REMOVED FROM THE RIGHT-OF-WAY (OR JOB SITE) ON A DAILY BASIS.
- THE CONTRACTOR SHALL DISPOSE OF ALL DEBRIS UPON COMPLETION OF THE PROJECT.
- THE EROSION CONTROL PLAN SHALL BE IN ACCORDANCE WITH THE FDOT/FDEP EROSION & SEDIMENT CONTROL HANDBOOK.
- ALL FILL MATERIAL SHALL BE SELECT FILL AS DEFINED BY FDOT DESIGN STANDARD INDEX 505.
- DEWATERING: SHOULD LOWERING OF GROUNDWATER BE NECESSARY FOR THE INSTALLATION OF CONCRETE STRUCTURES, OR TO PREVENT LATERAL MOVEMENT OF CONCRETE ALREADY PLACED, SUCH LOWERING SHALL BE ACCOMPLISHED BY MEANS OF A WELL POINT SYSTEM OR OTHER APPROVED MEANS, AT CONTRACTOR'S EXPENSE. COMPREHENSIVE PLANS FOR DEWATERING OPERATIONS, IF USED, SHALL BE SUBMITTED BY THE CONTRACTOR PRIOR TO INSTALLATION. THE CONTRACTOR SHALL BE RESPONSIBLE FOR ALL PERMITTING ASSOCIATED WITH DEWATERING.
- THE CONTRACTOR SHALL BE RESPONSIBLE FOR ACQUIRING NPDES PERMIT.
- THE CONTRACTOR SHALL REPAIR OR REPLACE ANY METERS, VALVES, SERVICE LATERALS, FIRE HYDRANTS, MAINS, WATER, WASTEWATER, OR GAS FACILITIES DAMAGED DURING CONSTRUCTION AT NO ADDITIONAL COST.
- ALL PROPOSED INLETS SHALL HAVE 18" SUMP BOTTOMS .OPEN BOTTOMS SHALL NOT BE ALLOWED IN AREAS WHERE HIGH GROUNDWATER EXISTS.
- ALL DEMOLISHED MATERIALS SHALL BE REMOVED FROM SITE AND DISPOSED OF IN A LEGAL MANNER.
- CONTRACTOR SHALL PROVIDE (5) SIGNED AND SEALED AS-BUILT SURVEYS PREPARED BY A REGISTERED FLORIDA SURVEYOR. A DIGITAL (AUTOCAD) FILE SHALL ALSO BE PROVIDED.

UTILITY GENERAL NOTES:

- ALL MAINS SHALL BE INSTALLED ACCORDING TO ENGINEERING PLANS AND SPECIFICATIONS.
- ALL VALVES AND MATERIALS SHALL COMPLY WITH AWWA (AMERICAN WATER WORKS ASSOCIATION) STANDARDS, LATEST EDITION.
- ALL MAIN LINE VALVES SHALL BE RESILIENT SEATED GATE VALVES.
- THE CONTRACTOR WILL BE REQUIRED TO REMOVE & REPLACE ITEMS ENCOUNTERED IN THE FIELD, ie SIGNS, FENCING, POST, etc..
- MAINS SHALL HAVE A MINIMUM OF 36" COVER UNLESS APPROVED BY ENGINEER.
- CONTRACTOR IS TO FURNISH "AS BUILT PLANS" INDICATING LOCATIONS OF ALL FITTINGS, VALVES, AND DEAD END RUNS WITH THREE (3) PHYSICAL FEATURES (LOT CORNERS, TREES, ETC.).
- ALL WATER MAINS SHALL BE DISINFECTED IN ACCORDANCE WITH AWWA C651. PRESSURE TESTING SHALL BE IN ACCORDANCE WITH AWWA C600.
- CONTRACTOR SHALL NOTIFY AND COORDINATE WITH ENGINEER 48 HOURS PRIOR TO PRESSURE TESTING, DISINFECTION, AND BACTERIOLOGICAL TESTING. PRESSURE TESTING SHALL BE VALVE TO VALVE. CONTRACTOR SHALL USE 2" AIR RELEASE VALVE PORTS OR SHALL TAP THE WATER MAIN WITH A 1" TAPPING SADDLE.
- BASE AND BACKFILL MATERIALS SHALL BE EITHER OF THE SAME TYPE AND COMPOSITION AS THE MATERIALS REMOVED, OR OF EQUAL OR GREATER STRUCTURAL ADEQUACY. MATERIALS CONTAMINATED WITH DELETERIOUS SUBSTANCES DURING EXCAVATION SHALL NOT BE USED FOR FILL.
- CONTRACTOR SHALL BE RESPONSIBLE FOR ALL FITTINGS, TAPS, EQUIPMENT AS REQUIRED FOR FLUSHING SYSTEM, PRESSURE TESTING, DISINFECTION, AND BACTERIOLOGICAL TESTING.
- THE CONTRACTOR SHALL BE RESPONSIBLE FOR DETERMINING THE EXACT LOCATION OF EXISTING UTILITIES, AND TO DETERMINE IF OTHER UTILITIES WILL BE ENCOUNTERED DURING THE COURSE OF THE WORK, AND TAKE WHATEVER STEP NECESSARY TO PROVIDE FOR THEIR PROTECTION.
- UTILITIES SHOWN ON THE PLAN MAY NOT BE ACCURATE AND ALL UTILITIES MAY NOT BE SHOWN.
- THE CONTRACTOR SHALL NOTIFY ALL UTILITY OWNERS 48 HOURS PRIOR TO COMMENCING CONSTRUCTION AND SHALL VERIFY LOCATION OF ALL UTILITIES PRIOR TO EXCAVATION.
- ALL VALVE BOXES SHALL BE INSTALLED PER DETAIL SHOWN. PRE-CAST VALVE PADS SHALL NOT BE USED. ALL VALVE BOX RISERS SHALL BE DUCTILE IRON, NOT PVC.
- ALL PAVEMENT SHALL BE CUT AND PATCHED IN ACCORDANCE WITH ENGINEERING PLANS AND SPECIFICATIONS.
- ALL CONCRETE ENCASED DUCTILE IRON SHALL BE WRAPPED WITH A PLASTIC MATERIAL AND TAPED TOGETHER BEFORE CONCRETE IS PLACED AROUND THE PIPE.
- WHERE THERE IS LESS THAN 12" CLEARANCE BETWEEN PVC/DI PIPE AND OTHER PIPE OR SPECIFIED AREAS, THE PIPE SHALL BE ENCASED WITH 6" THICKNESS AROUND THE PIPE AND 6" CLEARANCE EACH WAY IN THE AXIAL DIRECTION.
- THE CONTRACTOR SHALL REMOVE AND REPLACE, TO THEIR ORIGINAL NATURE, ALL DISTURBED MATERIALS OR OBJECTS WITHIN THE PATH OF THE NEW UTILITIES AS NECESSARY. ALL REPLACED MATERIALS SHALL BE EQUAL OR BETTER AND SHALL BE APPROVED BY THE ENGINEER. THIS INCLUDES ALL LANDSCAPING WITHIN THE RIGHT OF WAY IN THE PATH OF THE NEW UTILITIES.
- THE CONTRACTOR SHALL VISIT THE SITE PRIOR TO BIDDING. THE SURVEY MAY NOT SHOW ALL OBJECTS WITHIN THE PATH OF THE NEW UTILITIES. IF OBJECTS ARE NOT SHOWN ON THE SURVEY, THE CONTRACTOR SHALL NOTIFY THE ENGINEER WITHIN 7 DAYS PRIOR TO THE BID DATE. CONTRACTOR WILL BE RESPONSIBLE FOR REPLACEMENT OF ALL OBJECTS NOT SHOWN ON THE SURVEY.
- ALL CONSTRUCTION AREAS NEAR WETLANDS ARE TO BE MONITORED CLOSELY FOR EROSION. SILT FENCE AND HAY BALES SHALL BE USED IN THESE AREAS. CONTRACTOR SHALL FOLLOW ALL THE FDEP/COE DREDGE AND FILL PERMIT REQUIREMENTS IF APPLICABLE. SEE SPECIFICATIONS.
- ALL SPOIL MATERIAL SHALL BE PLACED ON THE UPLAND SIDE OF ANY SLOPED CONSTRUCTION AREA.
- THE CONTRACTOR SHALL TAKE WHATEVER STEPS NECESSARY TO PREVENT EROSION INTO NEARBY WETLANDS.
- THE CONTRACTOR SHALL USE RESTRAINED JOINT PIPE FOR ALL BENDS, TEES, VALVES, AND TRANSITION FITTINGS.
- INSULATED 12 GA. LOCATING WIRE SHALL BE INSTALLED ON TOP OF ALL NON-METALIC PIPE, WHICH INCLUDES SERVICE CONNECTIONS. ALL LOCATING WIRE SHALL BE CONNECTED AND SHALL TERMINATE IN VALVE BOXES AND METER BOXES AS SHOWN IN THE DETAILS.
- ALL PIPE SHALL BE INSTALLED IN DRY CONDITIONS. WELL POINTING MAY BE REQUIRED AT THE DIRECTION OF THE ENGINEER. WELL POINTS OR SOCK PIPE MAY BE USED.
- THE FLUSHING VELOCITY SHALL BE A MINIMUM OF 3 FEET PER SECOND FOR 3 TIMES THE PIPE VOLUME. THE OWNER WILL PAY FOR THE FIRST FLUSH AND PRESSURE TEST WATER. THE CONTRACTOR WILL PAY FOR ANY WATER FOR ADDITIONAL REPAIRS, FLUSHING, AND TESTING. THE CONTRACTOR SHALL PROVIDE ALL TEMPORARY ABOVE GROUND OUTLETS AND VALVES FOR FLUSHING THE PIPES ON THIS PROJECT.
- CONTRACTOR SHALL FOLLOW ALL OSHA REQUIREMENTS FOR CONSTRUCTION.
- THE CONTRACTOR SHALL FOLLOW ALL CONDITIONS OF THE PERMIT REQUIREMENTS. SEE SPECIFICATIONS FOR COPY OF PERMITS.
- ALL DISTURBED AREAS SHALL BE SODDED.
- A ONE FOOT STRIP OF SOD SHALL BE INSTALLED ON THE EDGE OF ALL ASPHALT OVERLAY AREAS AND AROUND ALL ABOVE GROUND CONCRETE STRUCTURES INCLUDING BUT NOT LIMITED TO VALVE PADS, BLOW OFF VAULTS, AND AIR RELEASE VAULTS.
- CONTRACTOR SHALL PROVIDE ALL FITTINGS, SLEEVES AND TRANSITION ADAPTERS AS NECESSARY TO COMPLETE THIS PROJECT.
- CONTRACTOR SHALL COMPLETE RESTORATION WITHIN 2 WEEKS OF SUCCESSFUL PIPE PRESSURE TESTING AT ANY GIVEN LOCATION. TEST SHALL BE PERFORMED VALVE TO VALVE WITHIN ONE WEEK OF COMPLETING THAT SECTION. PRESSURE TESTING SHALL TAKE PLACE EVERY 2 WEEKS DURING CONSTRUCTION FOR ANY PIPE INSTALLED IN THAT PERIOD.

UTILITY CONTACTS:

OWNER	CONTACT	PHONE
BAY COUNTY TRAFFIC	BOB EDMUNDS	850-248-8760
CITY OF PANAMA CITY	MATT STANDLEY	850-872-3191
KNOLOGY HOLDINGS	STEVE THOMAS	850-215-2138
COMCAST CABLE	JEFFERY SMITH	850-770-8056
SOUTHERN LIGHT	ANDRO BRAMBLETT	251-662-1170
GULF POWER	KENNY DOUGLAS	850-505-5567
AT&T	NANCY SPENCE	770-918-5424
AT&T DISTRIBUTION	DANNEY WATSON	334-850-7761
TECO GAS	ROLAND MOORE	850-914-6129

EROSION AND SEDIMENT CONTROL NOTES:

CONSTRUCTION:

- CONTRACTOR SHALL STAGE AND TIME CONSTRUCTION TO MINIMIZE THE SIZE OF EXPOSED SOIL AREAS AND THE TIME BETWEEN EXPOSING THE SOIL AREA AND FINISHING THE SOIL AREA.
- AS SOON AS GRADING IS COMPLETE IN AN AREA, THE CONTRACTOR WILL STABILIZE THE SOIL. FOR LONG, NARROW AREAS, THE CONTRACTOR SHALL STABILIZE CONTINUOUSLY DURING GRADING OPERATIONS. ROUGH GRADED AREAS SHOULD BE STABILIZED WITH TEMPORARY EROSION CONTROL. IF FINAL GRADING AND STABILIZATION WILL NOT BE PERFORMED WITHIN FIVE (5) DAYS, FAILURE TO STABILIZE EXPOSED SOIL AREAS IN A TIMELY MANNER AFTER GRADING MAY BE CONSIDERED A VIOLATION OF CHAPTERS 17-3, 17-12, AND/OR 17-25, FLORIDA ADMINISTRATIVE CODE, BY THE FLORIDA DEPARTMENT OF ENVIRONMENTAL PROTECTION (FDEP) AND SUBJECT TO CORRECTIVE ACTION, PURSUANT TO SECTION 403.121- 403.161 FLORIDA STATUTES.
- IT SHALL BE THE RESPONSIBILITY OF THE CONTRACTOR PERFORMING A TASK TO PROVIDE EROSION CONTROL. UNLESS ANOTHER PARTY HAS BEEN PREVIOUSLY SPECIFIED AS RESPONSIBLE FOR THE EROSION CONTROL ASSOCIATED WITH THAT TASK. IN THE EVENT ANOTHER PARTY IS RESPONSIBLE FOR EROSION CONTROL, THE CONTRACTOR SHALL STILL BE RESPONSIBLE FOR COORDINATION WITH THE PARTY RESPONSIBLE. IN THE EVENT THAT DAMAGE TO THE CONSTRUCTED ITEM RESULTS ARE DUE TO LACK OF EROSION CONTROL, THE CONTRACTOR SHALL REPAIR OR REPLACE THE ITEM AT NO CHARGE TO THE OWNER.
- TEMPORARY EROSION CONTROL SHALL CONSIST OF TEMPORARY GRASS, TEMPORARY MULCH, TEMPORARY SOD, ARTIFICIAL COVERINGS, BALED HAY OR STRAW, SILT FENCES, AND TURBIDITY BARRIERS. TEMPORARY EROSION CONTROL SHALL BE IN ACCORDANCE WITH SECTION 104 OF THE FLORIDA DEPARTMENT OF TRANSPORTATION (FDOT) STANDARD SPECIFICATIONS.
- PERMANENT EROSION CONTROL SHALL CONSIST OF SEED, SEED AND MULCH, HYDRO-SEEDING, SOD, AND/OR ARTIFICIAL COVERINGS. PERMANENT EROSION CONTROL SHALL BE IN ACCORDANCE WITH SECTIONS 570 AND 575 OF THE FDOT STANDARD SPECIFICATIONS. SEED OR GRASS TYPE SHALL MATCH EXISTING OR BE AS SPECIFIED BY OWNER UNLESS NOTED OTHERWISE.
- GRASS BY SEEDING SHALL BE IN ACCORDANCE WITH SECTIONS 104, 570, 981, 982, AND 983 OF FDOT STANDARD SPECIFICATIONS. THIS SHALL BE USED ONLY IN AREAS SUBJECT TO LIGHT EROSION SUCH AS FLAT AREAS.
- GRASS BY HYDRO-SEEDING SHALL BE IN ACCORDANCE WITH SECTIONS 104, 570, 981, 982, AND 983 OF FDOT STANDARD SPECIFICATIONS. HYDRO-SEEDING MAY BE USED FOR FLAT AREAS AND SIDE SLOPES WHICH DO NOT EXCEED 2:1. DRAINAGE DITCHES OR LARGE SWALES MUST HAVE ADDITIONAL PROTECTION BESIDES HYDRO-SEEDING.
- GRASS AND MULCH SHALL BE IN ACCORDANCE WITH SECTIONS 104, 570, 981, 982, AND 983 OF FDOT STANDARD SPECIFICATIONS. GRASS AND MULCH MAY BE USED IN ALL AREAS EXCEPT LARGE SWALES OR DITCHES. MULCH SHALL BE ANCHORED IN ACCORDANCE WITH SECTION 570. SOLID SOD SHALL BE IN ACCORDANCE WITH SECTIONS 104, 575, 981, 982, AND 983 OF FDOT STANDARD SPECIFICATIONS. SOD MAY BE USED IN ALL AREAS FOR SIDE SLOPES LESS THAN 2:1. SOD SHOULD NOT BE USED ON SLOPES GREATER THAN 1:2 (V:H). EROSION CONTROL BLANKETS WITH GRASSING OR OTHER SLOPE STABILIZATION TECHNIQUES SHOULD BE USED ON SLOPES GREATER THAN 1:2. SOD SHALL BE STAGGERED SO AS TO AVOID A CONTINUOUS SEAM. IN AREAS WITH SLOPES 3:1 OR STEEPER, EACH PIECE OF SOD SHALL BE PEGGED WITH SOD PEGS. IN DIFFICULT SOIL CONDITIONS WITH STEEP SLOPES, IT MAY BE NECESSARY TO COVER SOD WITH ARTIFICIAL COVERINGS SUCH AS JUTE MESH UNTIL SOD BECOMES ESTABLISHED.
- TEMPORARY EROSION CONTROL BY ARTIFICIAL COVERINGS SHALL CONSIST OF STRAW BLANKETS, COCONUT FIBER BLANKETS, POLYESTER BLANKETS, JUTE MESH, AND DRAINAGE FABRICS. MATERIALS SHALL BE INSTALLED IN ACCORDANCE WITH MANUFACTURER'S RECOMMENDATIONS. SEEDING SHALL BE INCLUDED IF MATERIAL REQUIRES VEGETATION TO FUNCTION PROPERLY.
- THE CONTRACTOR IS TO PROVIDE EROSION CONTROL/ SEDIMENTATION BARRIER (HAY BALES, SILT FENCE, TURBIDITY BARRIER, OR AS SPECIFIED IN THE CONSTRUCTION DRAWINGS) TO PREVENT SILTATION OF ADJACENT PROPERTY, STREETS, STORM SEWERS, WATERWAYS, AND WETLAND OR JURISDICTIONAL AREAS. IF, IN THE OPINION OF THE ENGINEER, AND/OR REGULATORY AUTHORITIES, EXCESSIVE QUANTITIES OF MATERIAL ARE TRANSPORTED OFFSITE BY EROSION OR STORM WATER RUNOFF, THE CONTRACTOR SHALL IMPROVE CONDITIONS TO THE SATISFACTION OF THE ENGINEER AND/OR AUTHORITIES IN NO CASE SHALL CONSTRUCTION COMMENCE PRIOR TO INSTALLATION OF EROSION CONTROL/SEDIMENTATION BARRIER.
- CONTRACTOR SHALL PLACE STRAW, MULCH, OR OTHER SUITABLE MATERIAL ON GROUND IN AREAS WHERE CONSTRUCTION-RELATED TRAFFIC IS TO ENTER AND EXIT SITE.
- IF WIND EROSION BECOMES SIGNIFICANT DURING CONSTRUCTION, THE CONTRACTOR SHALL STABILIZE THE AREA USING SPRINKLING IRRIGATION OR OTHER ACCEPTABLE METHODS.

MAINTENANCE:

- THE CONTRACTOR SHALL PROVIDE ROUTINE MAINTENANCE OF PERMANENT AND TEMPORARY EROSION CONTROL FEATURES. UNTIL THE PROJECT IS COMPLETED AND ACCEPTED, THEN MAINTENANCE SHALL BE IN ACCORDANCE WITH SECTION 104 OF THE FLORIDA DEPARTMENT OF TRANSPORTATION (FDOT) STANDARD SPECIFICATIONS OR BAY COUNTY SPECIFICATIONS.
- SILT FENCES AND TURBIDITY BARRIERS SHALL BE CHECKED DAILY FOR EFFECTIVENESS, BREACHES, AND ROUTINE MAINTENANCE.

PAVING, GRADING, AND EARTH WORK NOTES:

CONSTRUCTION:

- ALL AREAS DISTURBED BY CONSTRUCTION ACTIVITIES SHALL BE SEEDED, MULCHED, SODDED, STABILIZED, OR PLANTED WITH OTHER APPROVED LANDSCAPE MATERIAL, WITHIN FIVE (5) DAYS AFTER CONSTRUCTION.
- ALL WASTE MATERIAL SHALL BE DISPOSED OF OFFSITE IN ACCORDANCE WITH APPLICABLE REGULATIONS.
- PROPOSED SPOT ELEVATIONS REPRESENT PAVEMENT OR GROUND SURFACE GRADE UNLESS OTHERWISE NOTED ON DRAWINGS.
- CONTRACTOR TO PROVIDE 1/2" TO 1" BITUMINOUS EXPANSION JOINT MATERIAL WITH SEALER AT ABUTMENT OF CONCRETE AND OTHER MATERIALS (BUILDINGS, OTHER POURED CONCRETE, ETC.) EXCEPT ASPHALT.
- CONTRACTOR SHALL TRIM, TACK AND MATCH EXISTING PAVEMENT AT LOCATIONS WHERE NEW PAVEMENT ABUTS.
- TESTING SHALL BE IN GENERAL CONFORMANCE WITH THE FDOT SPECIFICATIONS FOR ROAD AND BRIDGE CONSTRUCTION, LATEST EDITION. SELECTION AND CONTRACTING WITH THE TESTING FIRMS SHALL BE THE RESPONSIBILITY OF THE CONTRACTOR. IT SHALL BE THE RESPONSIBILITY OF THE CONTRACTOR TO COORDINATE AND SCHEDULE ALL TESTS, AND PROVIDE TO THE ENGINEER OF RECORD.
- ALL POTHoles WITHIN THE LIMITS OF PROJECT SHALL BE FILLED WITH ASPHALT AND COMPACTED PRIOR TO RESURFACING.
- TOP SOIL SHALL BE PLACED IN AREAS WHERE SOD IS PROPOSED, PRIOR TO INSTALLATION OF SOD.

SIGNING AND MARKING NOTES:

- FOR SIGN DETAILS, USE THE MANUAL OF UNIFORM TRAFFIC CONTROL DEVICES PUBLISHED BY THE US DEPARTMENT OF TRANSPORTATION, FEDERAL HIGHWAY ADMINISTRATION, 2009.
- ALL SIGNAGE AND WHEEL STOPS SHALL BE REMOVED AND STOCKPILED ON SITE. CONTRACTOR SHALL COORDINATE STOCKPILE LOCATION WITH PROJECT ADMINISTRATOR.
- THE SIGN LOCATIONS ARE APPROXIMATE AND MAY REQUIRE FIELD ADJUSTMENT AS DIRECTED BY THE PROJECT ADMINISTRATOR.
- SIGNING AND PAVEMENT MARKINGS SHALL BE PLACED IN ACCORDANCE WITH CURRENT MUTCD, AMERICANS WITH DISABILITIES ACT, FDOT DESIGN STANDARDS (CURRENT EDITION), AND THE PLANS.
- THE PAVEMENT MARKINGS AT ALL EXISTING/PROPOSED INTERFACE LOCATIONS SHALL MATCH IN TERMS OF ALIGNMENT AND COLOR.
- ALL FINAL PROPOSED STRIPING AND MESSAGES SHALL BE THERMOPLASTIC. TEMPORARY STRIPING SHALL BE PAINT.



FLORIDA ARCHITECTS
 LICENSE #A00002730
 648 Florida Avenue
 Panama City, FL 32401
 P 850/257-5400

JONATHAN SKLARSKI
 FL. P.E. 67361

Principal in Charge
 Joseph J. Sorci
 Project Number:
 4166-2
 Date Issued:
 5-7-2015
 Drawn By:
 BWR
 Checked By:
 J.S.
 Revisions:



PREBLE-RISH, INC.

GULF COAST STATE COLLEGE
 PHASE 1 CAMPUS
 IMPROVEMENTS

GENERAL NOTES

BID DOCUMENTS
 Sheet Number

C1

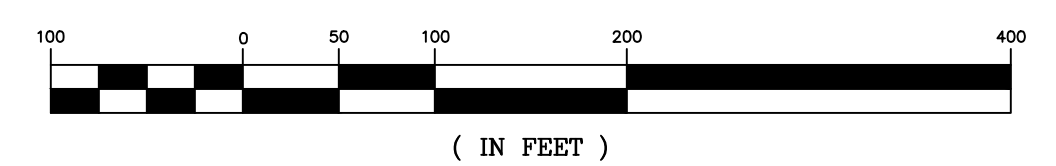
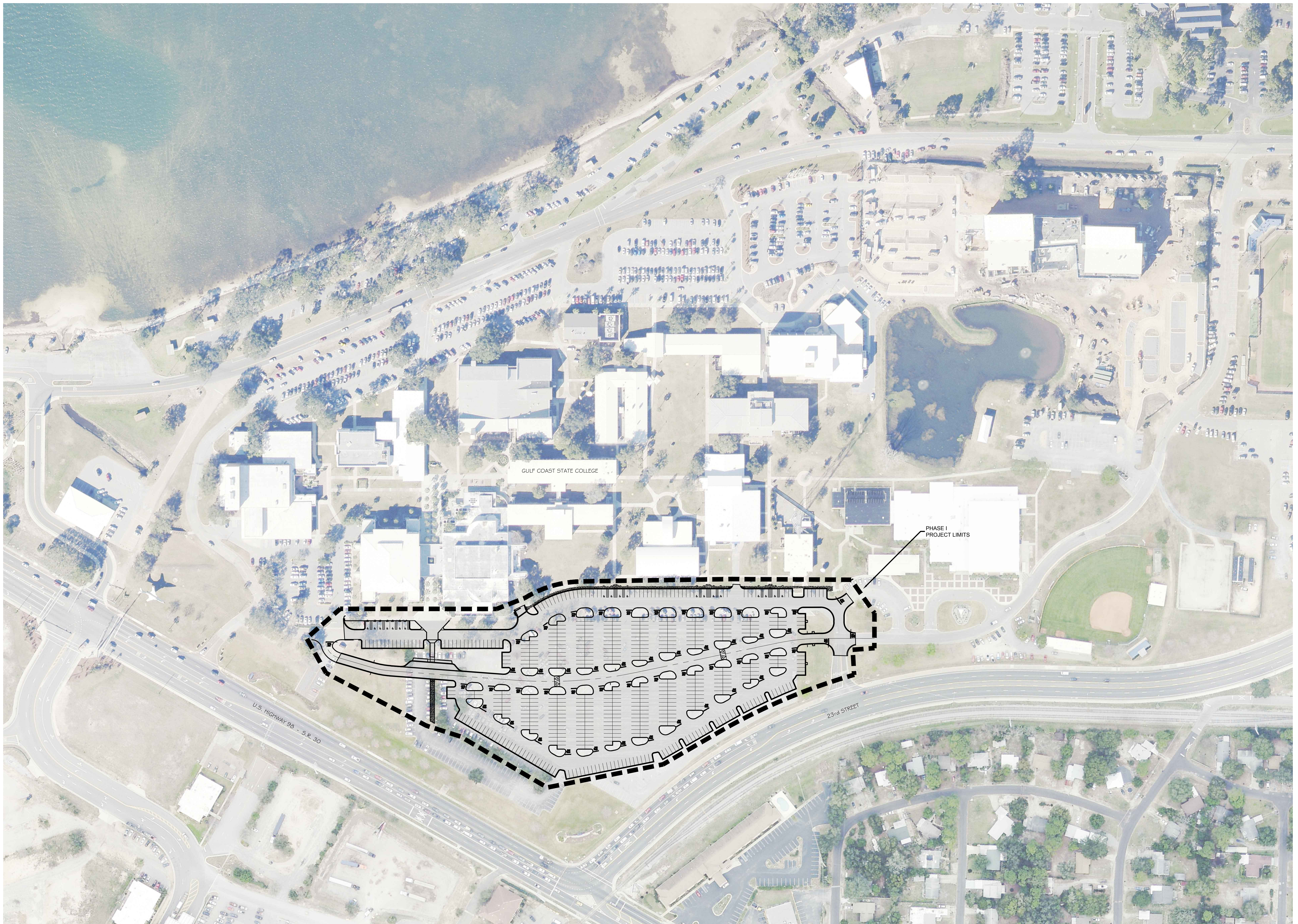

GRAPHIC SCALE

(IN FEET)

JONATHAN SKLARSKI
FL. P.E. 67361

Principal in Charge
Joseph J. Sorci
Project Number:
4166-2
Date Issued:
5-7-2015
Drawn By:
BWR
Checked By:
J.S.
Revisions:



GULF COAST STATE COLLEGE
PHASE 1 CAMPUS
IMPROVEMENTS

OVERALL SITE PLAN

Copyright © 2015 by Florida Architects, Inc. All rights reserved. This drawing is the property of Florida Architects, Inc. and is not to be reproduced, changed or copied in any form or manner, nor are they to be assigned to any party without the architects written consent.

May 6, 2015 (14-21-48 EST)
K:\7852.007_655C_PC_PHASE1\CIVIL3\FOLDER_PRODUCTION\782007_0A1STEP1AN.DWG

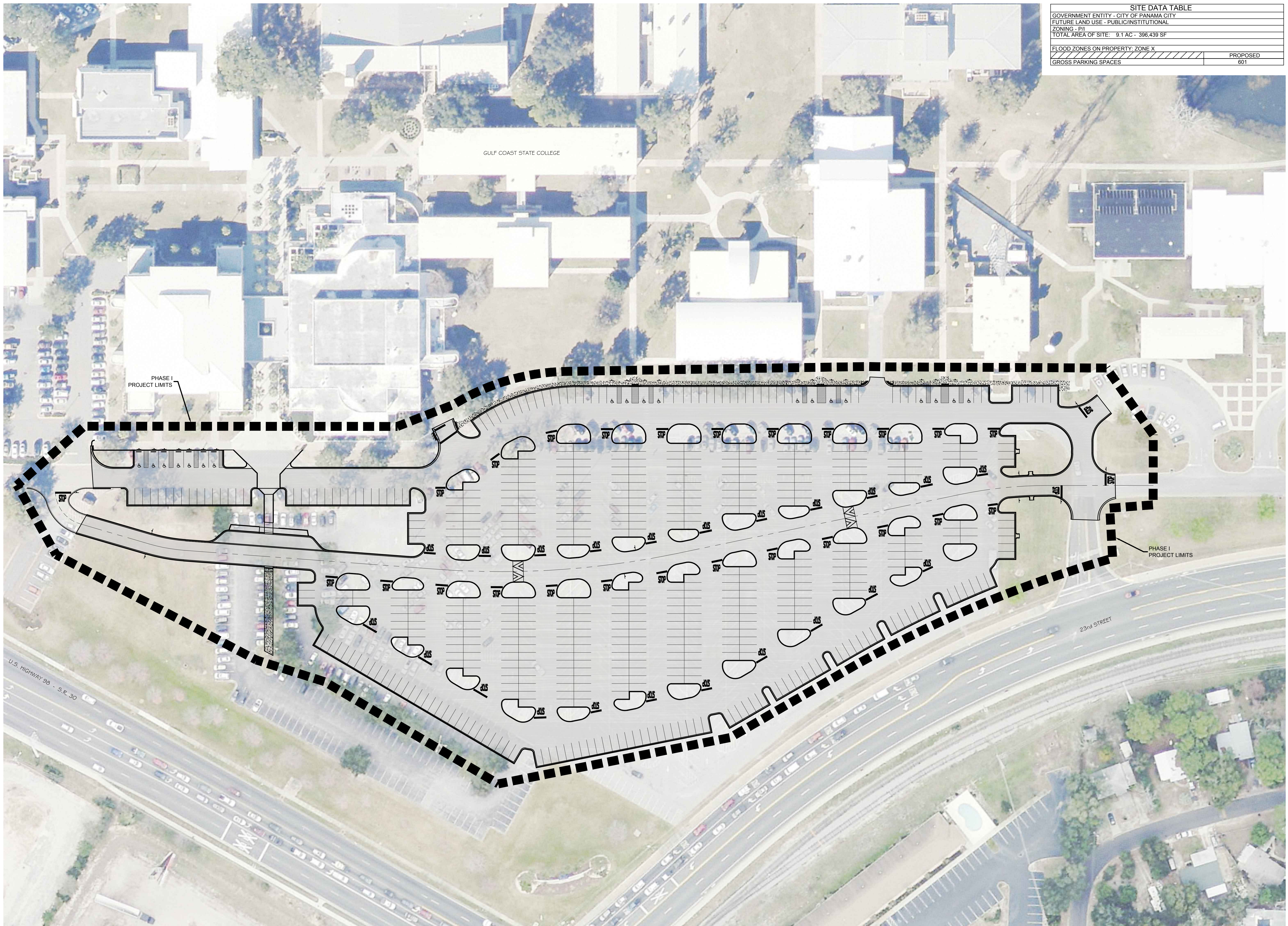

SITE DATA TABLE	
GOVERNMENT ENTITY - CITY OF PANAMA CITY	
FUTURE LAND USE - PUBLIC/INSTITUTIONAL	
ZONING - PI	
TOTAL AREA OF SITE: 9.1 AC - 396,438 SF	
FLOOD ZONES ON PROPERTY: ZONE X	
GROSS PARKING SPACES	PROPOSED 601

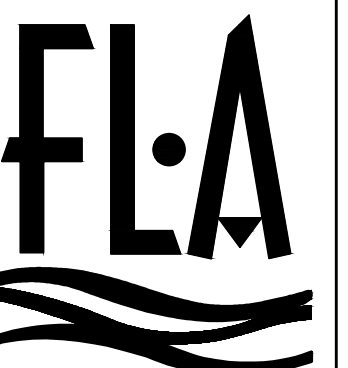

FLORIDA ARCHITECTS
 LICENSE #AA0002730
 648 Florida Avenue
 Panama City, FL 32401
 P 850/257-5400

JONATHAN SKLARSKI
 FL P.E. 67361

Principal in Charge
 Joseph J. Sorci
 Project Number:
 4166-2
 Date Issued:
 5-7-2015
 Drawn By:
 BWR
 Checked By:
 J.S.
 Revisions:



**GULF COAST STATE COLLEGE
 PHASE 1 CAMPUS
 IMPROVEMENTS**

PROJECT LIMITS

BID DOCUMENTS
 Sheet Number

C3

GRAPHIC SCALE

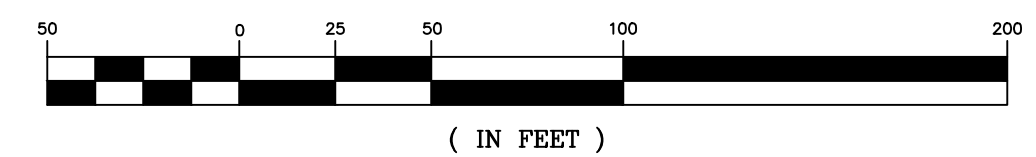

Copyright © 2015 BY FLORIDA ARCHITECTS, INC. ARCHITECT EXPRESSLY RESERVES HIS EXCLUSIVE COMMON LAW COPYRIGHT AND PROPERTY RIGHTS TO THESE DRAWINGS WHICH MAY NOT BE REPRODUCED, CHANGED OR COPIED IN ANY FORM OR MANNER, NOR ARE THEY TO BE ASSIGNED TO ANY PARTY WITHOUT THE ARCHITECT'S WRITTEN CONSENT.

May 6, 2015 (14:27:59 EST)
K:\7892.007_GCSO_PC_PHASE1\CIVIL3\FOLDER_PRODUCTION\782007_DEMOPLAN.DWG

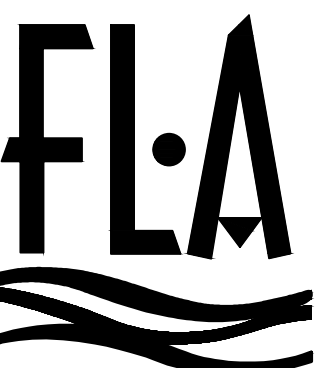
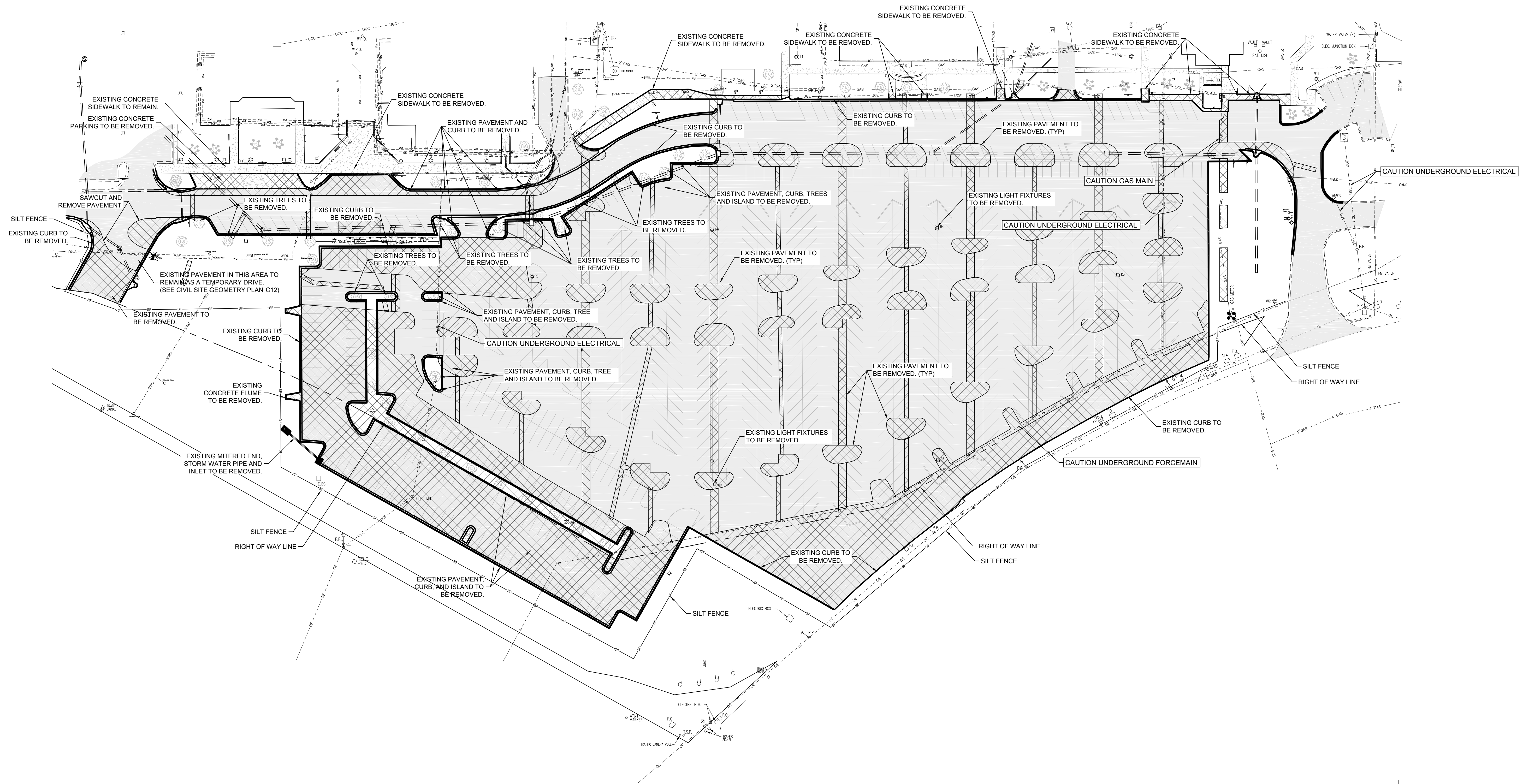

FLORIDA ARCHITECTS
LICENSE #AA0002730
648 Florida Avenue
Panama City, FL 32401
P 850/257-5400

JONATHAN SKLARSKI
FL. P.E. 67361

Principal in Charge
Joseph J. Sorci
Project Number:
4166-2
Date Issued:
5-7-2015
Drawn By:
BWR
Checked By:
J.S.
Revisions:



GULF COAST STATE COLLEGE
PHASE 1 CAMPUS
IMPROVEMENTS

DEMOLITION AND EROSION
CONTROL PLAN

BID DOCUMENTS
Sheet Number
C4

Copyright © 2015 by Florida Architects, Inc. All rights reserved. This drawing is the property of Florida Architects, Inc. and shall not be reproduced, changed or copied in any form or manner, nor are they to be assigned to any party without the architect's written consent.

WARNING: GAS MAIN IN AREA OF CONSTRUCTION



FLORIDA ARCHITECTS
LICENSE #AA0002730
648 Florida Avenue
Panama City, FL 32401
P 850/257-5400

JONATHAN SKLARSKI
FL P.E. 67361

Principal in Charge
Joseph J. Sorci
Project Number:
4166-2
Date Issued:
5-7-2015
Drawn By:
BWR
Checked By:
J.S.
Revisions:



PREBLE-RISH, INC.

OVERALL SITE UTILITY PLAN
GULF COAST STATE COLLEGE
PHASE 1 CAMPUS
IMPROVEMENTS

OVERALL SITE UTILITY PLAN
GULF COAST STATE COLLEGE
PHASE 1 CAMPUS
IMPROVEMENTS

BID DOCUMENTS
Sheet Number
C5

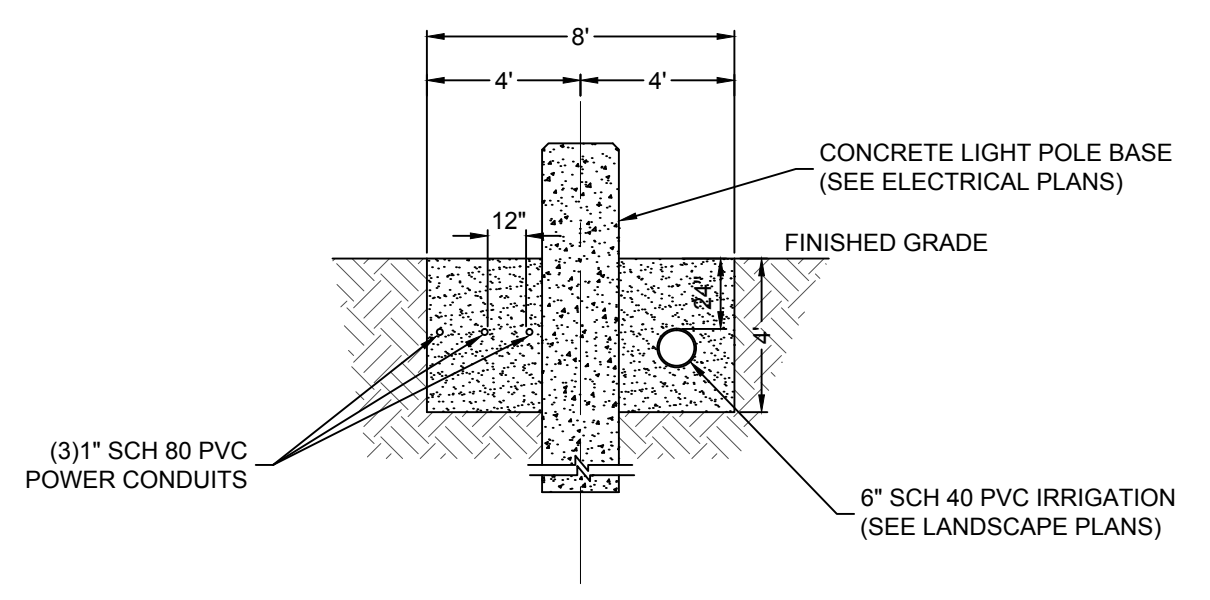
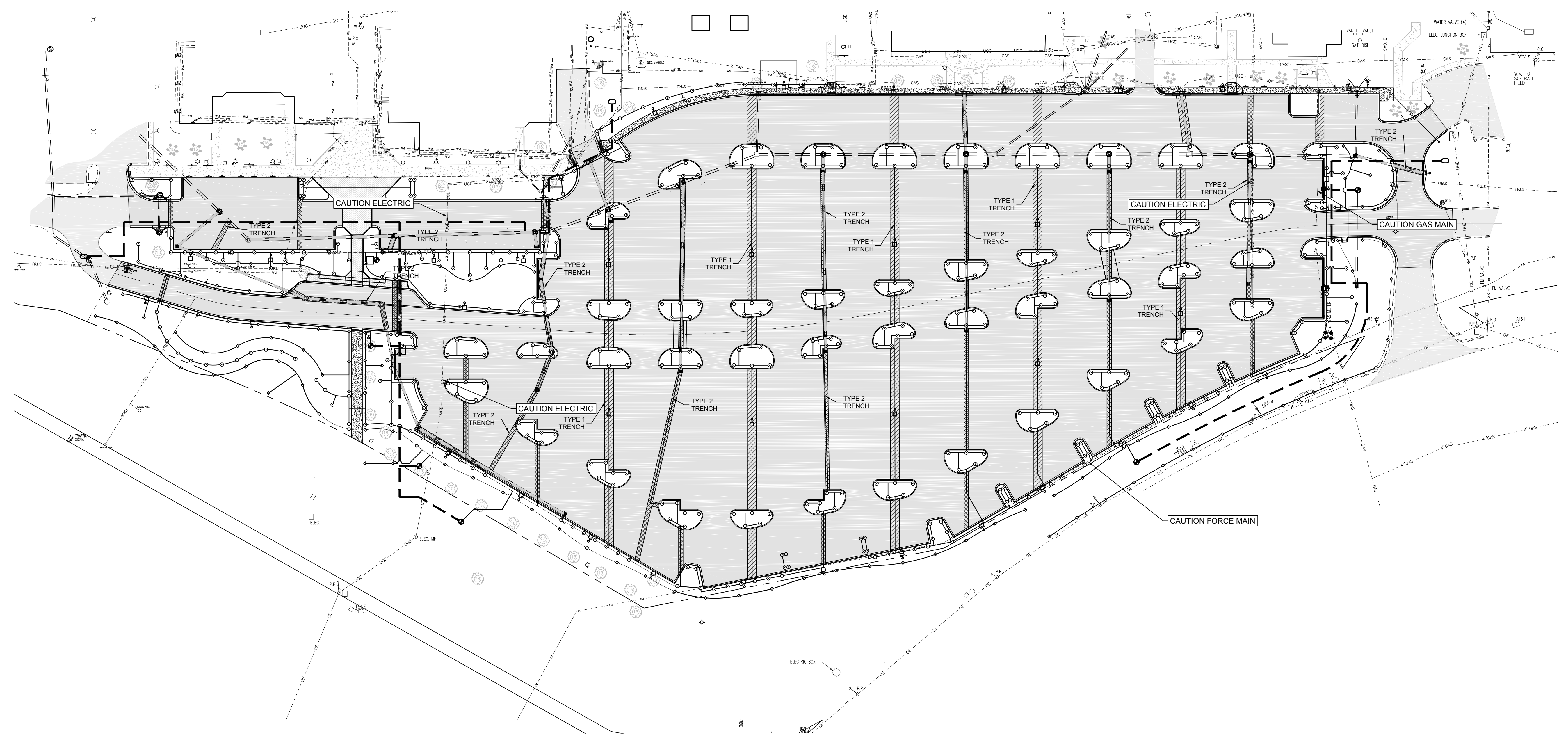

DETAIL TYPE 1 TRENCH
SCALE: N.T.S.

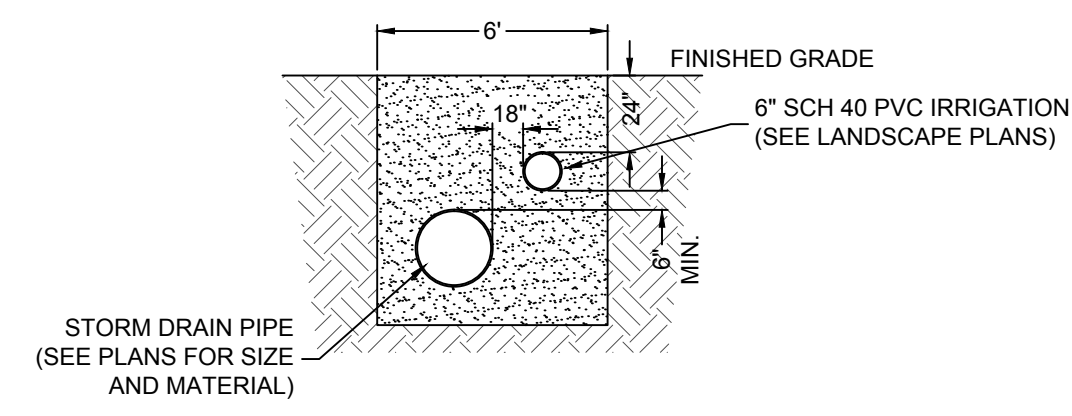

DETAIL TYPE 2 TRENCH
SCALE: N.T.S.

NOTE: SEE SHEET C19 FOR PAVING DETAILS FOR TYPE 1 AND TYPE 2 TRENCH

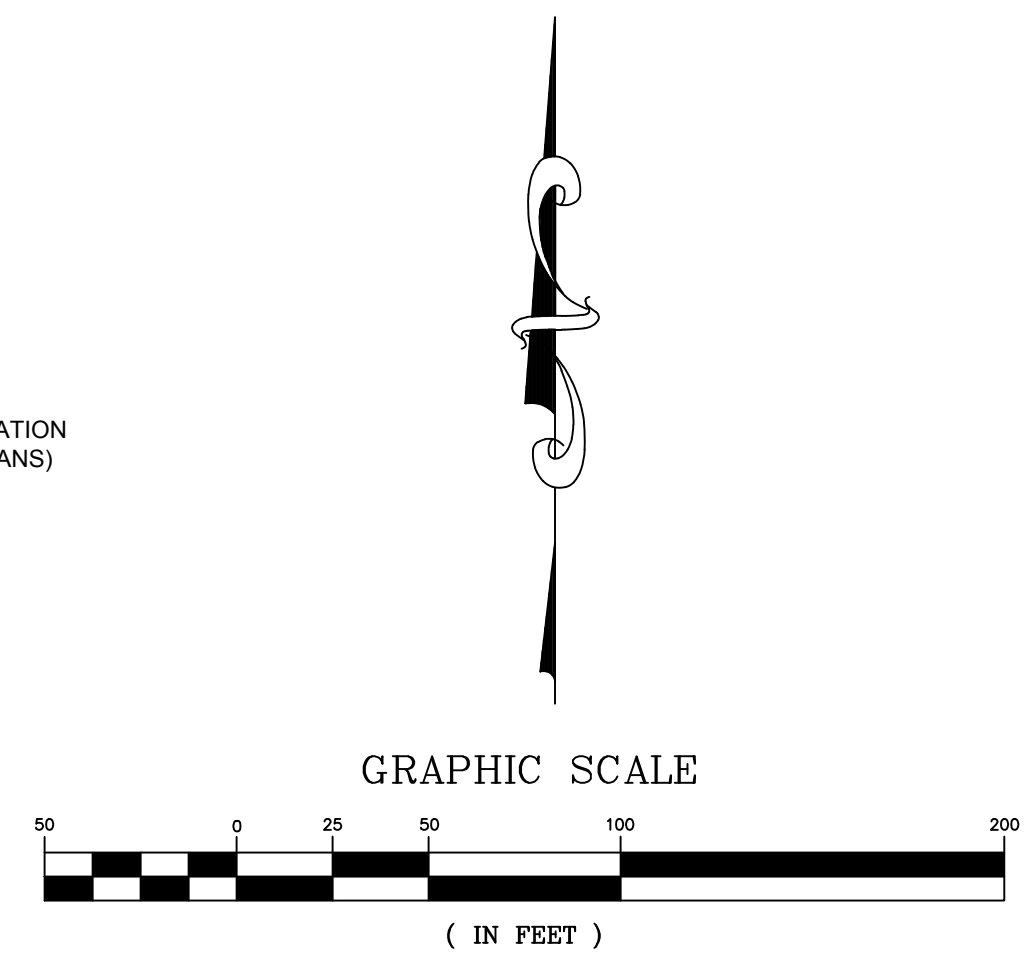

MAY 6, 2015 (14:41:07 EST)
K:\782007_GCSG_PC_PHASE1\CIVIL3\FOLDER_PRODUCTION\782007_STEP1A.DWG

Copyright © 2015 BY FLORIDA ARCHITECTS, INC. ARCHITECT EXPRESSLY RESERVES HIS EXCLUSIVE COMMON LAW COPYRIGHT AND PROPERTY RIGHTS TO THESE DRAWINGS WHICH MAY NOT BE REPRODUCED, CHANGED OR COPIED IN ANY FORM OR MANNER, NOR ARE THEY TO BE ASSIGNED TO ANY PARTY WITHOUT THE ARCHITECT'S WRITTEN CONSENT.



FLORIDA ARCHITECTS
 LICENSE #AA0002730
 648 Florida Avenue
 Panama City, FL 32401
 P 850/257-5400

JONATHAN SKLARSKI
 FL. P.E. 67361

Principal in Charge
 Joseph J. Sorci
 Project Number:
 4166-2
 Date Issued:
 5-7-2015
 Drawn By:
 BWR
 Checked By:
 J.S.
 Revisions:



PREBLE-RISH, INC.

GULF COAST STATE COLLEGE
 PHASE 1 CAMPUS
 IMPROVEMENTS

SITE UTILITY PLAN

BID DOCUMENTS
 Sheet Number
C6

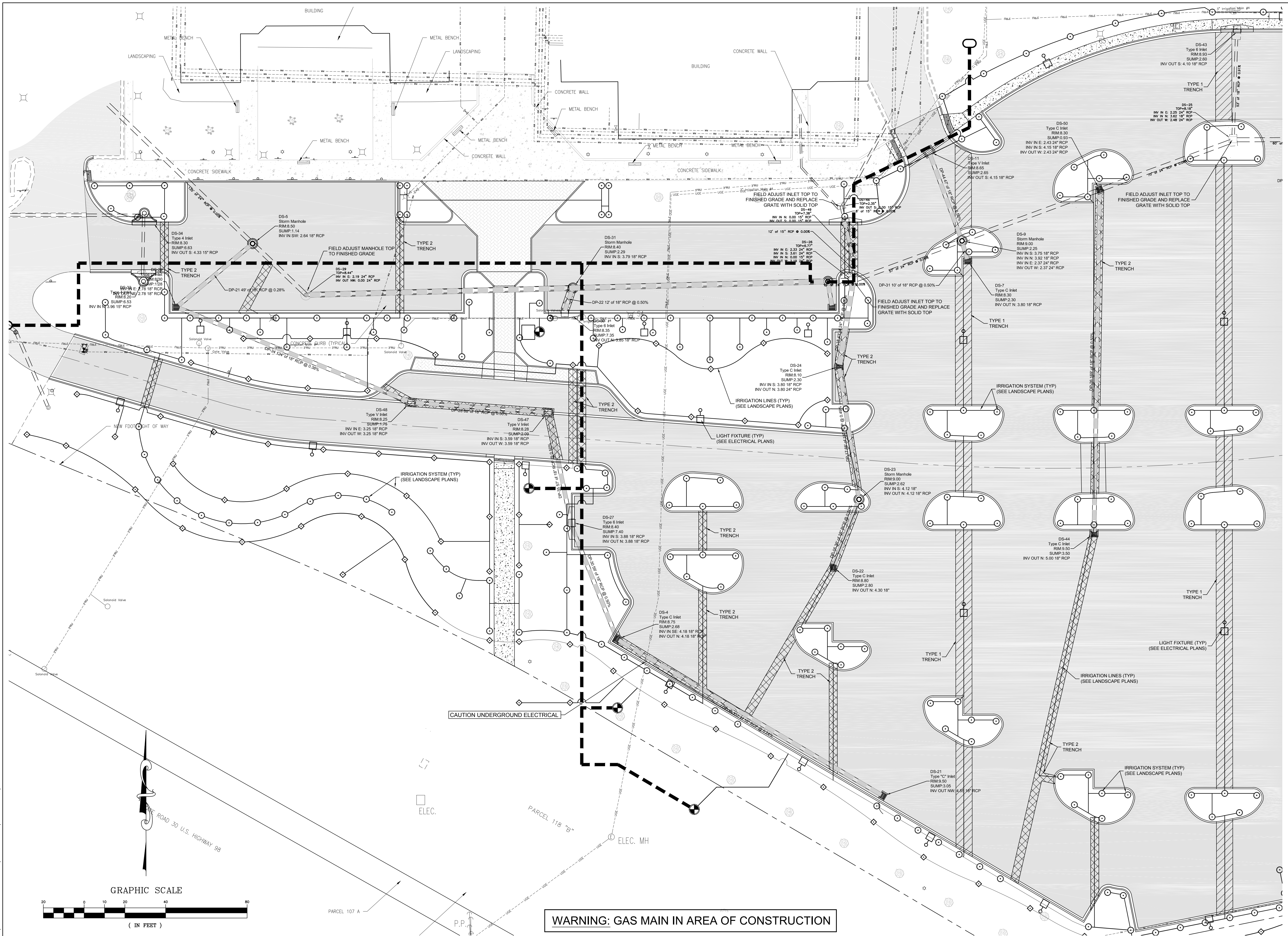

MAY 6, 2015 (14:41:07 EST)
 K:\7852\027 GCSC PC PHASE 1\01\3\FOLDER_V\PRODUCTION\782007_STEP1.DWG

GRAPHIC SCALE

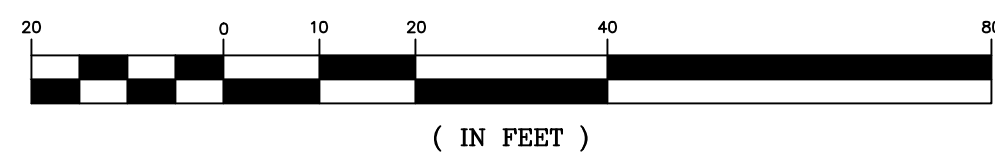

(IN FEET)

WARNING: GAS MAIN IN AREA OF CONSTRUCTION

Copyright © 2015 BY FLORIDA ARCHITECTS, INC. ARCHITECT EXPRESSLY RESERVES HIS EXCLUSIVE COMMON LAW COPYRIGHT AND PROPERTY RIGHTS TO THESE DRAWINGS WHICH MAY NOT BE REPRODUCED, CHANGED OR COPIED IN ANY FORM OR MANNER, NOR ARE THEY TO BE ASSIGNED TO ANY PARTY WITHOUT THE ARCHITECT'S WRITTEN CONSENT.

Nov 6, 2015 (14:41:07 EST)
K:\7852\027\655C_PC_PHASE\1\CIVIL3\FOLDER_V\PRODUCTION\782007_STEP1.DWG

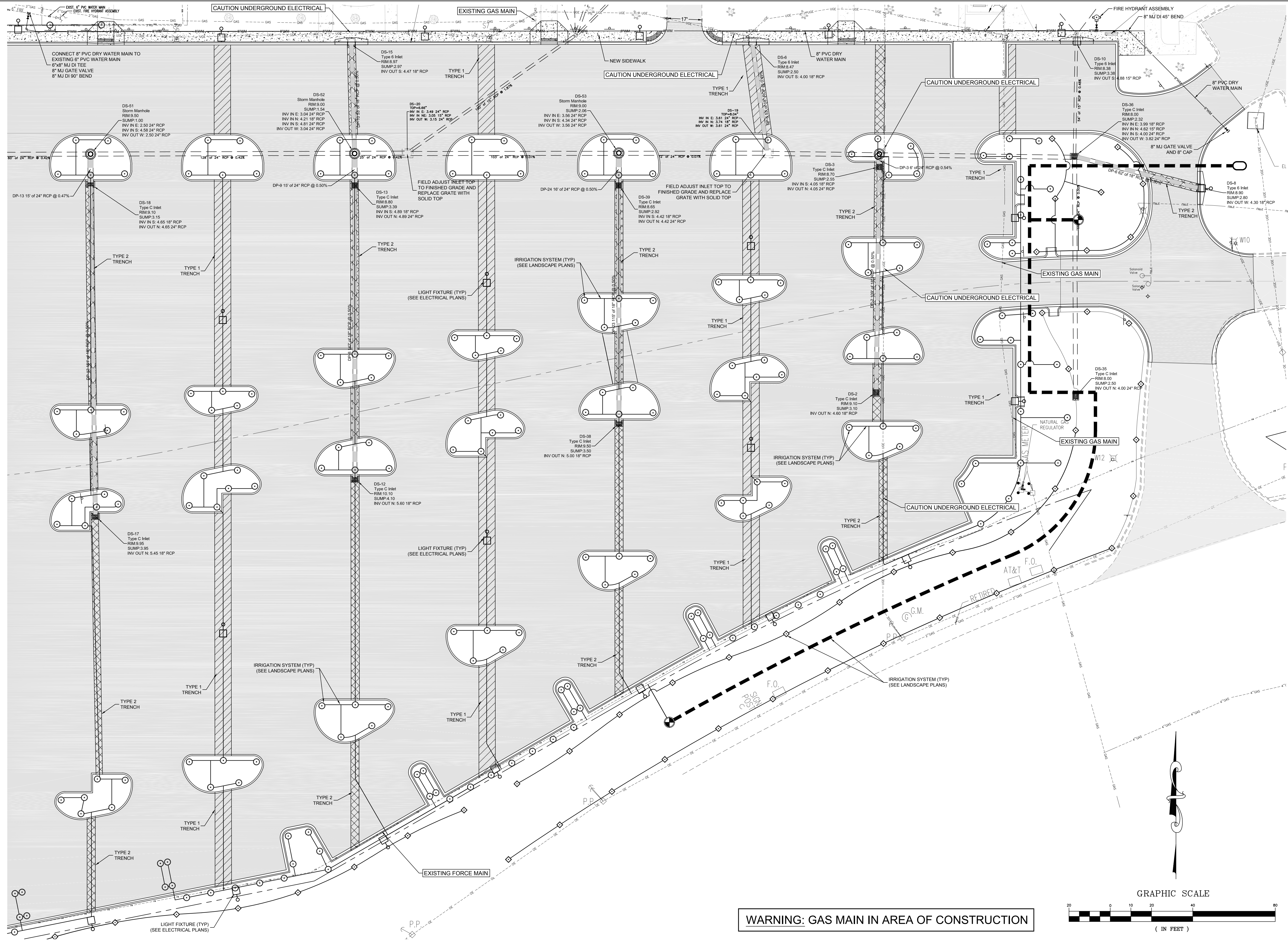

WARNING: GAS MAIN IN AREA OF CONSTRUCTION

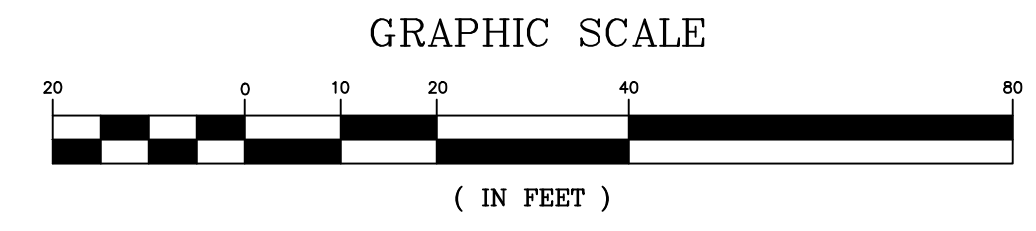

FLA
FLORIDA ARCHITECTS
 LICENSE #AA0002730
 648 Florida Avenue
 Panama City, FL 32401
 P 850/257-5400

JONATHAN SKLARSKI
 FL. P.E. 67361
 Principal in Charge
 Joseph J. Sorci
 Project Number:
 4166-2
 Date Issued:
 5-7-2015
 Drawn By:
 BWR
 Checked By:
 J.S.
 Revisions:



GULF COAST STATE COLLEGE
 PHASE 1 CAMPUS
 IMPROVEMENTS

SITE UTILITY PLAN

BID DOCUMENTS
 Sheet Number
C7

Copyright © 2015 by Florida Architects, Inc. All rights reserved. This drawing is the property of Florida Architects, Inc. and shall not be reproduced, changed or copied in any form or manner, nor are they to be assigned to any party without the architect's written consent.

WARNING: GAS MAIN IN AREA OF CONSTRUCTION



FLORIDA ARCHITECTS
LICENSE #AA0002730
648 Florida Avenue
Panama City, FL 32401
P 850/257-5400

JONATHAN SKLARSKI
FL P.E. 67361

Principal in Charge
Joseph J. Sorci
Project Number:
4166-2
Date Issued:
5-7-2015
Drawn By:
BWR
Checked By:
J.S.
Revisions:



PREBLE-RISH, INC.

GULF COAST STATE COLLEGE
PHASE 1 CAMPUS
IMPROVEMENTS

SITE PAVING PLAN

BID DOCUMENTS
Sheet Number
C8

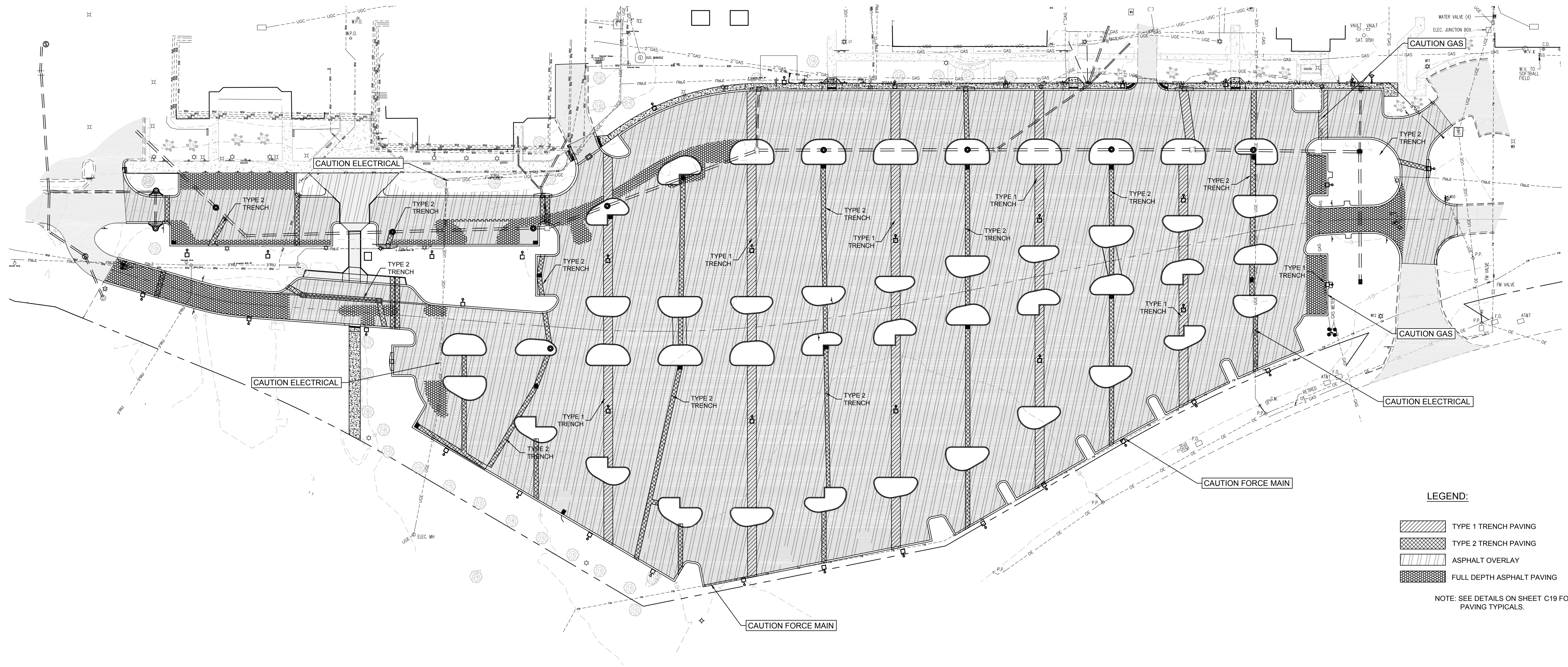

LEGEND:

- TYPE 1 TRENCH PAVING
- TYPE 2 TRENCH PAVING
- ASPHALT OVERLAY
- FULL DEPTH ASPHALT PAVING

NOTE: SEE DETAILS ON SHEET C19 FOR PAVING TYPICALS.

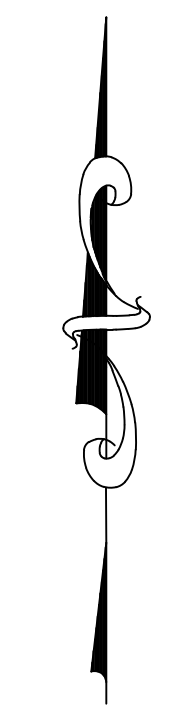

GRAPHIC SCALE

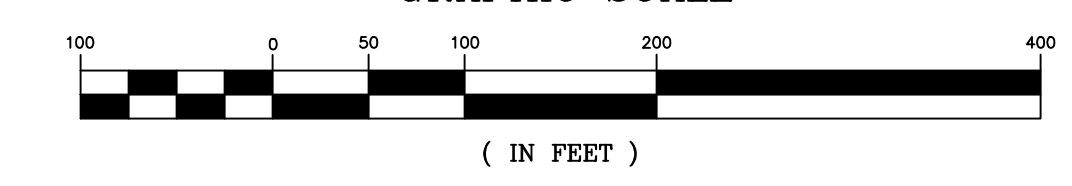

MAY 6, 2015 (14:41:07 EST)
K:\782007_GCSO_PC_PHASE1\CIVIL3D\FOLDER_PRODUCTION\782007_STEP1A.DWG

Copyright © 2015 BY FLORIDA ARCHITECTS, INC. ARCHITECT EXPRESSLY RESERVES HIS EXCLUSIVE COMMON LAW COPYRIGHT AND PROPERTY RIGHTS TO THESE DRAWINGS WHICH MAY NOT BE REPRODUCED, CHANGED OR COPIED IN ANY FORM OR MANNER, NOR ARE THEY TO BE ASSIGNED TO ANY PARTY WITHOUT THE ARCHITECT'S WRITTEN CONSENT.

WARNING: GAS MAIN IN AREA OF CONSTRUCTION



FLORIDA ARCHITECTS
LICENSE #AA0002730
648 Florida Avenue
Panama City, FL 32401
P 850/257-5400

JONATHAN SKLARSKI
FL. P.E. 67361

Principal in Charge
Joseph J. Sorci
Project Number:
4166-2
Date Issued:
5-7-2015
Drawn By:
BWR
Checked By:
J.S.
Revisions:



PREBLE-RISH, INC.

OVERALL SITE GRADING PLAN
GULF COAST STATE COLLEGE
PHASE 1 CAMPUS
IMPROVEMENTS

BID DOCUMENTS
Sheet Number
C9

MAY 6, 2015 (14:41:07 EST)
K:\782\007\0050\PC PHASE 1\01\3\FOLDER_V\PRODUCTION\782007_STEP1.DWG

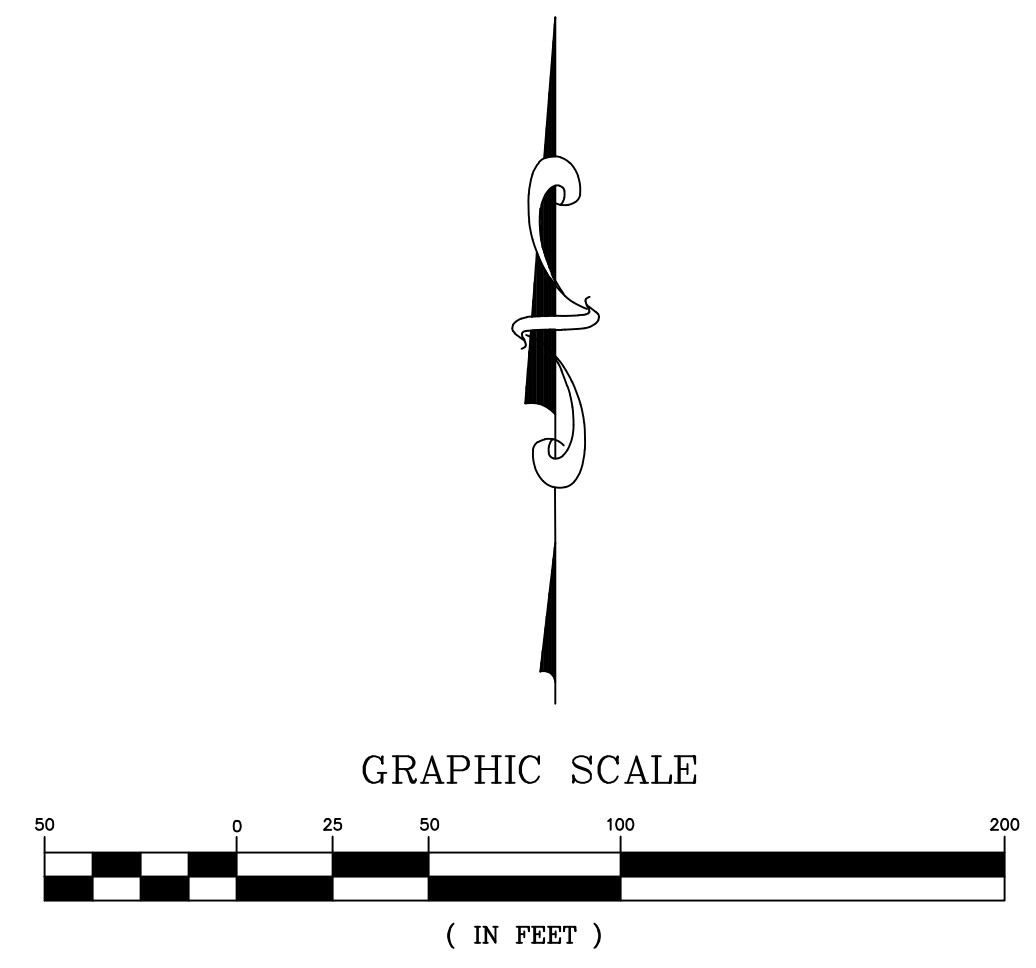
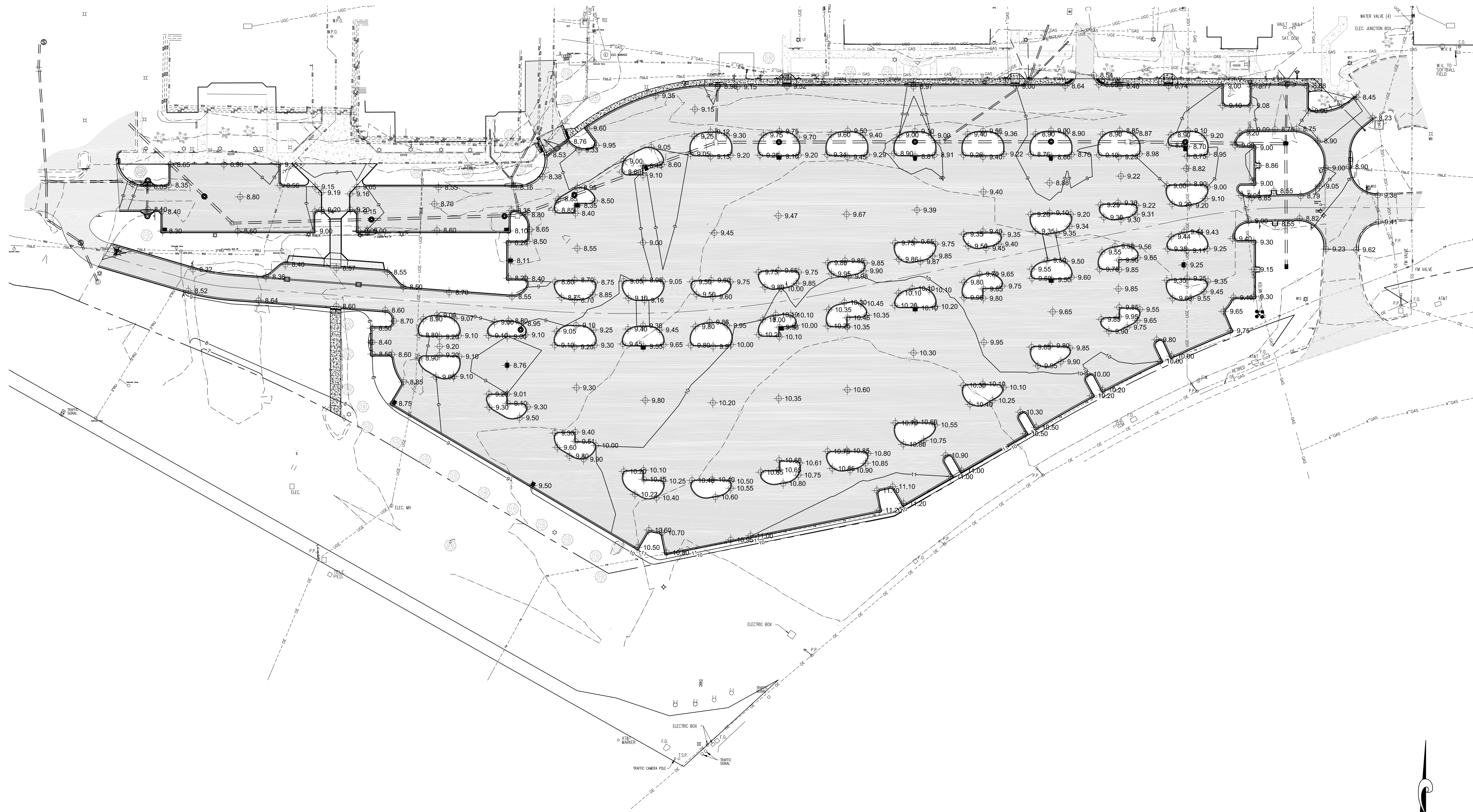

Copyright © 2015 BY FLORIDA ARCHITECTS, INC. ARCHITECT EXPRESSLY RESERVES HIS EXCLUSIVE COMMON LAW COPYRIGHT AND PROPERTY RIGHTS TO THESE DRAWINGS WHICH MAY NOT BE REPRODUCED, CHANGED OR COPIED IN ANY FORM OR MANNER, NOR ARE THEY TO BE ASSIGNED TO ANY PARTY WITHOUT THE ARCHITECT'S WRITTEN CONSENT.

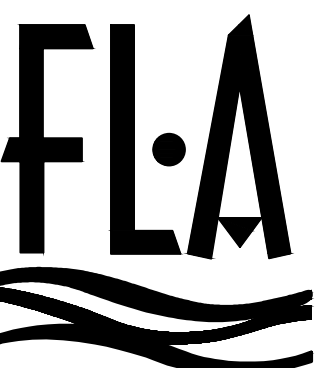

FLORIDA ARCHITECTS
 LICENSE #AA0002730
 648 Florida Avenue
 Panama City, FL 32401
 P 850/257-5400

JONATHAN SKLARSKI
 FL. P.E. 67361

Principal in Charge
 Joseph J. Sorci
 Project Number:
 4166-2
 Date Issued:
 5-7-2015
 Drawn By:
 BWR
 Checked By:
 J.S.
 Revisions:



PREBLE-RISH, INC.

GULF COAST STATE COLLEGE
 PHASE 1 CAMPUS
 IMPROVEMENTS

SITE GRADING PLAN

BID DOCUMENTS
 Sheet Number
C10

MAY 6, 2015 (14:41:07 EST)
 K:\7852.007_GCS.C_PC PHASE 1\CIVIL3D\FOLDER_L_PRODUCTION\782007_STEP1.DWG

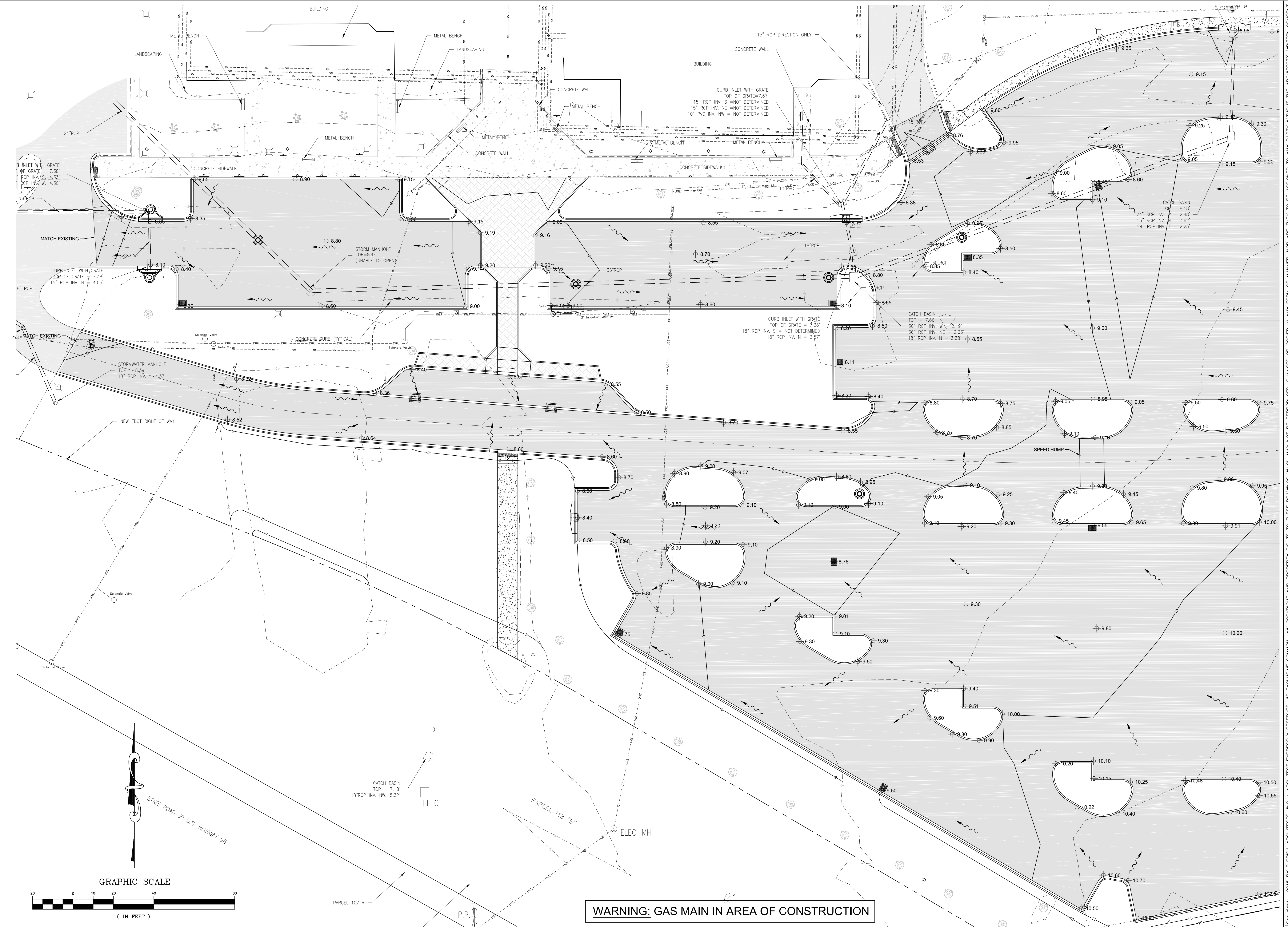

STATE ROAD 30 U.S. HIGHWAY 98

GRAPHIC SCALE

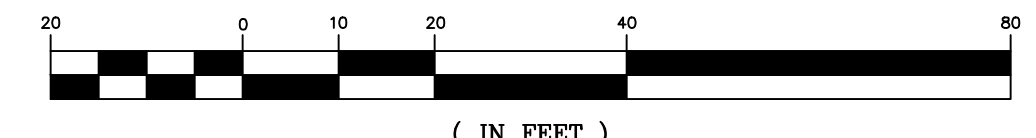

WARNING: GAS MAIN IN AREA OF CONSTRUCTION

Copyright © 2015 BY FLORIDA ARCHITECTS, INC. ARCHITECT EXPRESSLY RESERVES HIS EXCLUSIVE COMMON LAW COPYRIGHT AND PROPERTY RIGHTS TO THESE DRAWINGS WHICH MAY NOT BE REPRODUCED, CHANGED OR COPIED IN ANY FORM OR MANNER, NOR ARE THEY TO BE ASSIGNED TO ANY PARTY WITHOUT THE ARCHITECT'S WRITTEN CONSENT.

May 6, 2015 (14:41:07 EST)
K:\782007_GCSO_PC_PHASE\1\CIVIL3\FOLDER_L\PRODUCTION\782007_STEP1.DWG

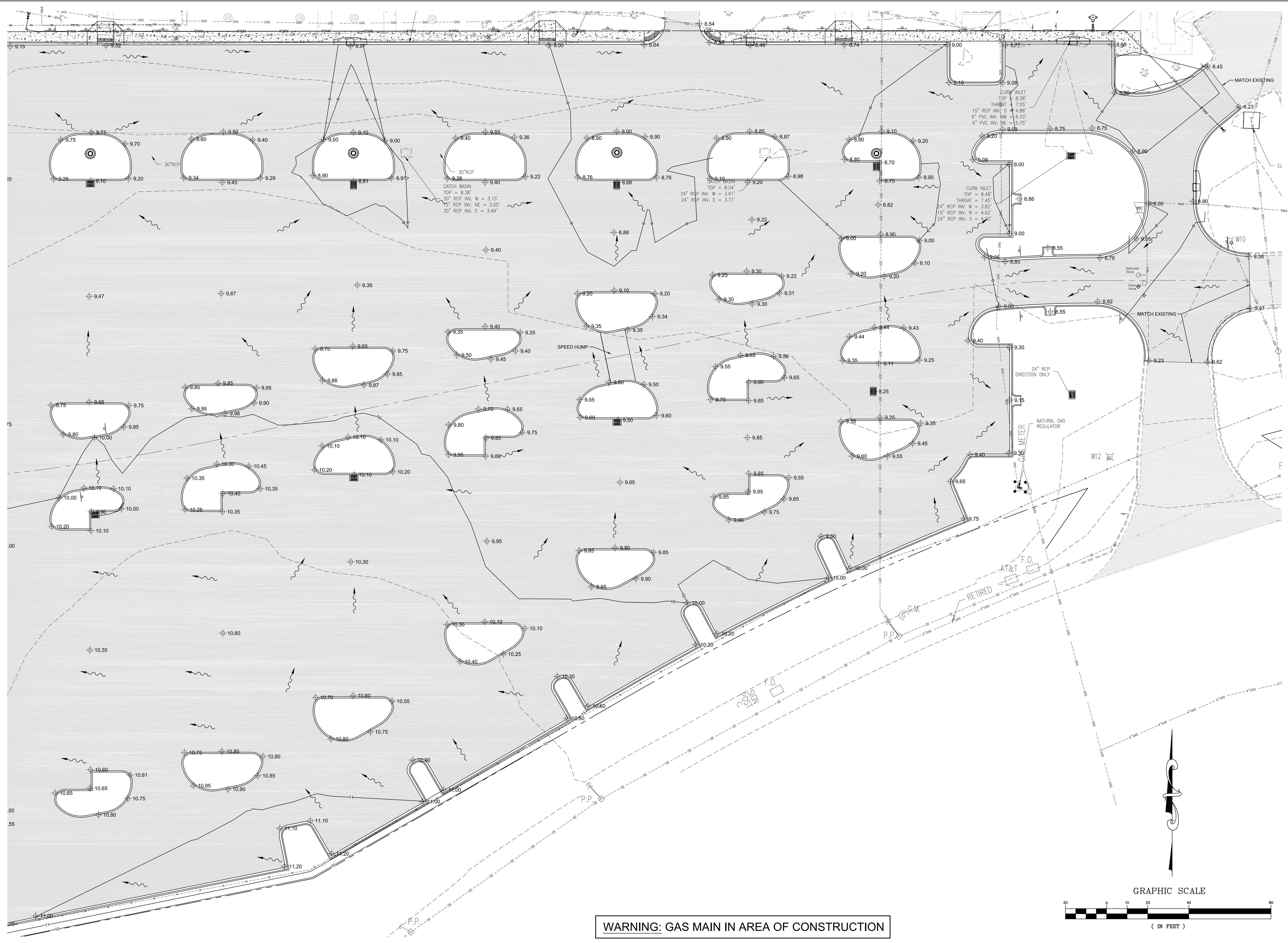

WARNING: GAS MAIN IN AREA OF CONSTRUCTION

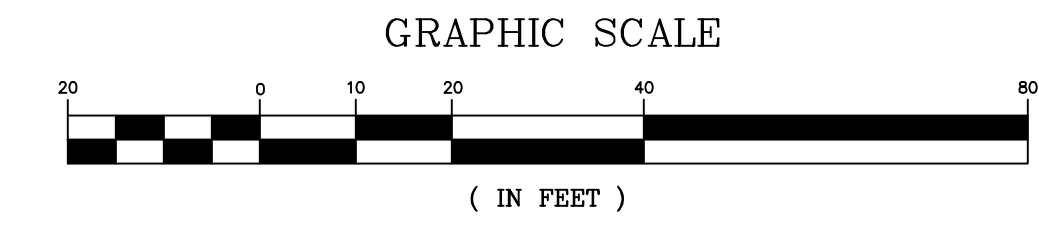

GRAPHIC SCALE
(IN FEET)



FLORIDA ARCHITECTS
LICENSE #AA0002730
648 Florida Avenue
Panama City, FL 32401
P 850/257-5400

JONATHAN SKLARSKI
FL. P.E. 67361

Principal in Charge
Joseph J. Sorci
Project Number:
4166-2
Date Issued:
5-7-2015
Drawn By:
BWR
Checked By:
J.S.
Revisions:



**GULF COAST STATE COLLEGE
PHASE 1 CAMPUS
IMPROVEMENTS**

SITE GRADING PLAN

BID DOCUMENTS
Sheet Number
C11

Copyright © 2015 BY FLORIDA ARCHITECTS, INC. ARCHITECT EXPRESSLY RESERVES HIS EXCLUSIVE COMMON LAW COPYRIGHT AND PROPERTY RIGHTS TO THESE DRAWINGS WHICH MAY NOT BE REPRODUCED, CHANGED OR COPIED IN ANY FORM OR MANNER, NOR ARE THEY TO BE ASSIGNED TO ANY PARTY WITHOUT THE ARCHITECT'S WRITTEN CONSENT.

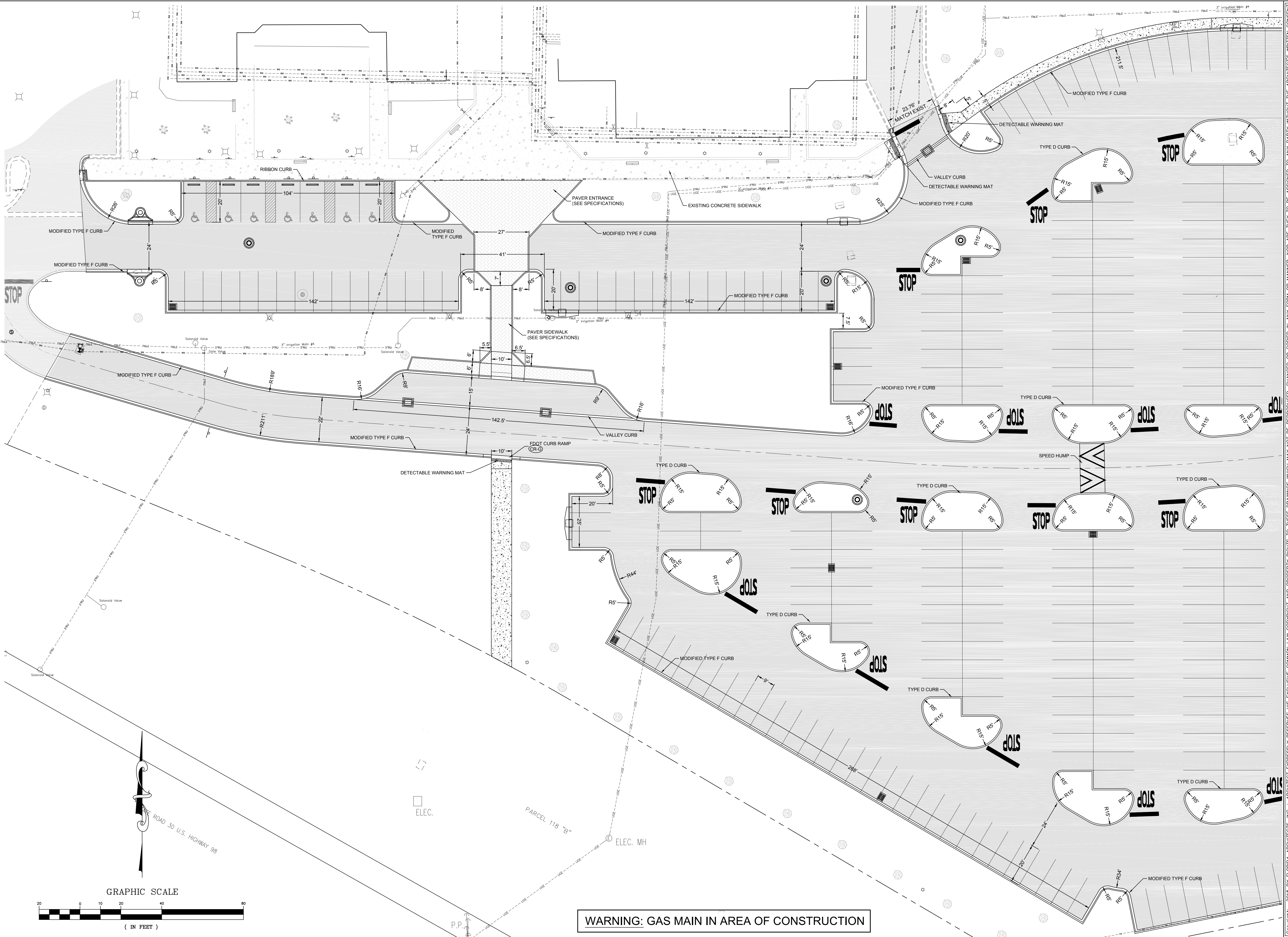

May 7, 2015 (09:16:08 EST)
 K:\7852\007\655C_PC_PHASE1\CIVIL\3\FOLDER_V\PRODUCTION\782007_STEP1.PLAN.DWG

GRAPHIC SCALE

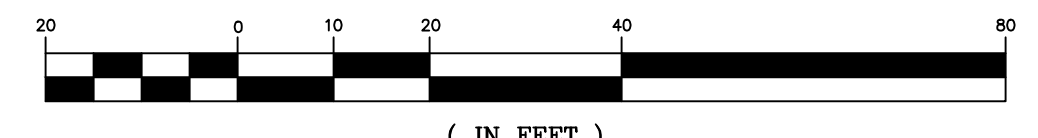

WARNING: GAS MAIN IN AREA OF CONSTRUCTION

Copyright © 2015 BY FLORIDA ARCHITECTS, INC. ARCHITECT EXPRESSLY RESERVES HIS EXCLUSIVE COMMON LAW COPYRIGHT AND PROPERTY RIGHTS TO THESE DRAWINGS WHICH MAY NOT BE REPRODUCED, CHANGED OR COPIED IN ANY FORM OR MANNER, NOR ARE THEY TO BE ASSIGNED TO ANY PARTY WITHOUT THE ARCHITECT'S WRITTEN CONSENT.

JONATHAN SKLARSKI
 FL. P.E. 67361

Principal in Charge
 Joseph J. Sorci
 Project Number:
 4166-2
 Date Issued:
 5-7-2015
 Drawn By:
 BWR
 Checked By:
 J.S.
 Revisions:



GULF COAST STATE COLLEGE
PHASE 1 CAMPUS IMPROVEMENTS

SITE GEOMETRY PLAN

MAY 6, 2015 (14:41:07 EST)
 K:\7852.007 GC5C PC PHASE 1\01\3\FOLDER_L\PRODUCTION\782007_STEP1.DWG

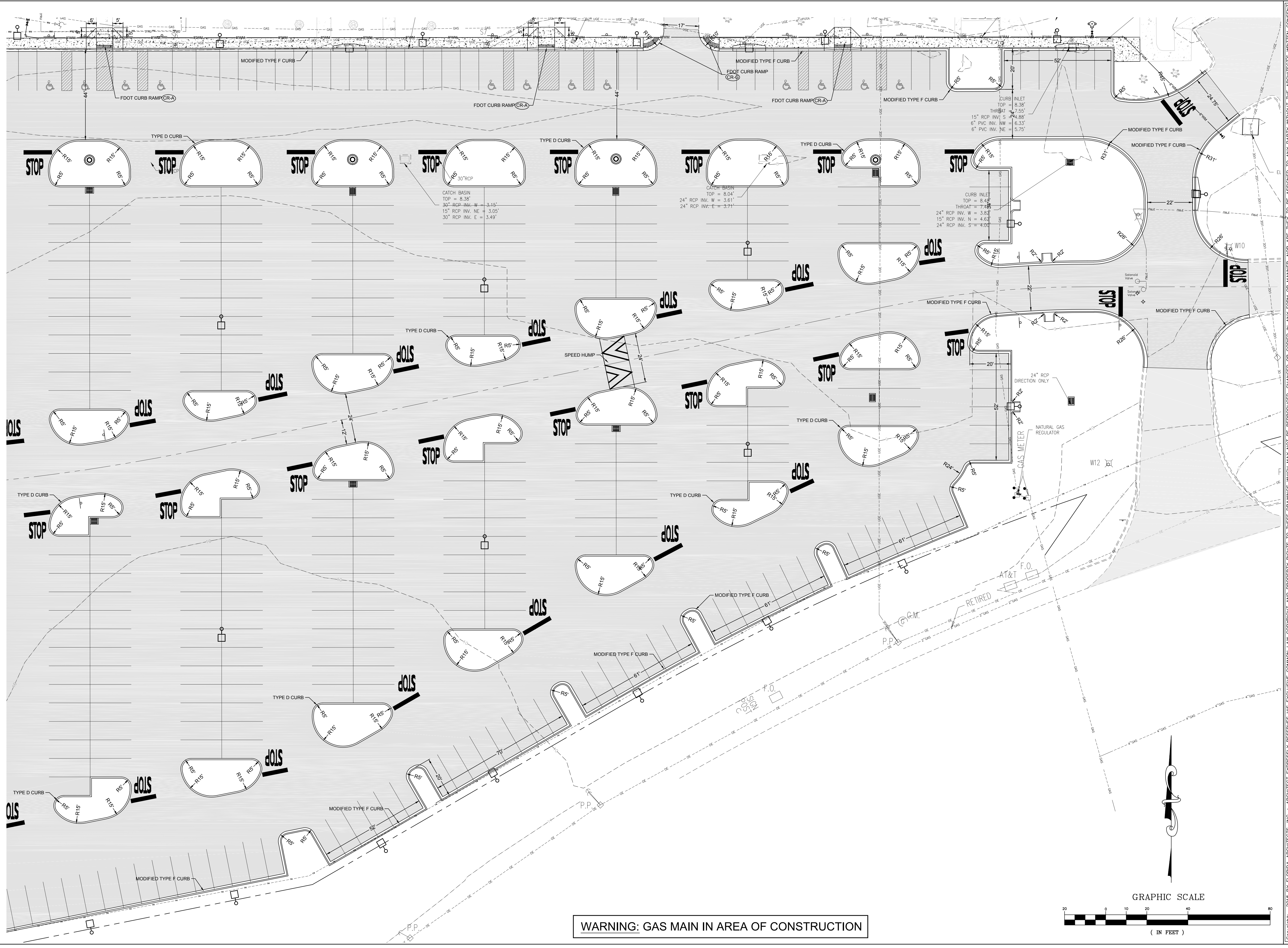

WARNING: GAS MAIN IN AREA OF CONSTRUCTION

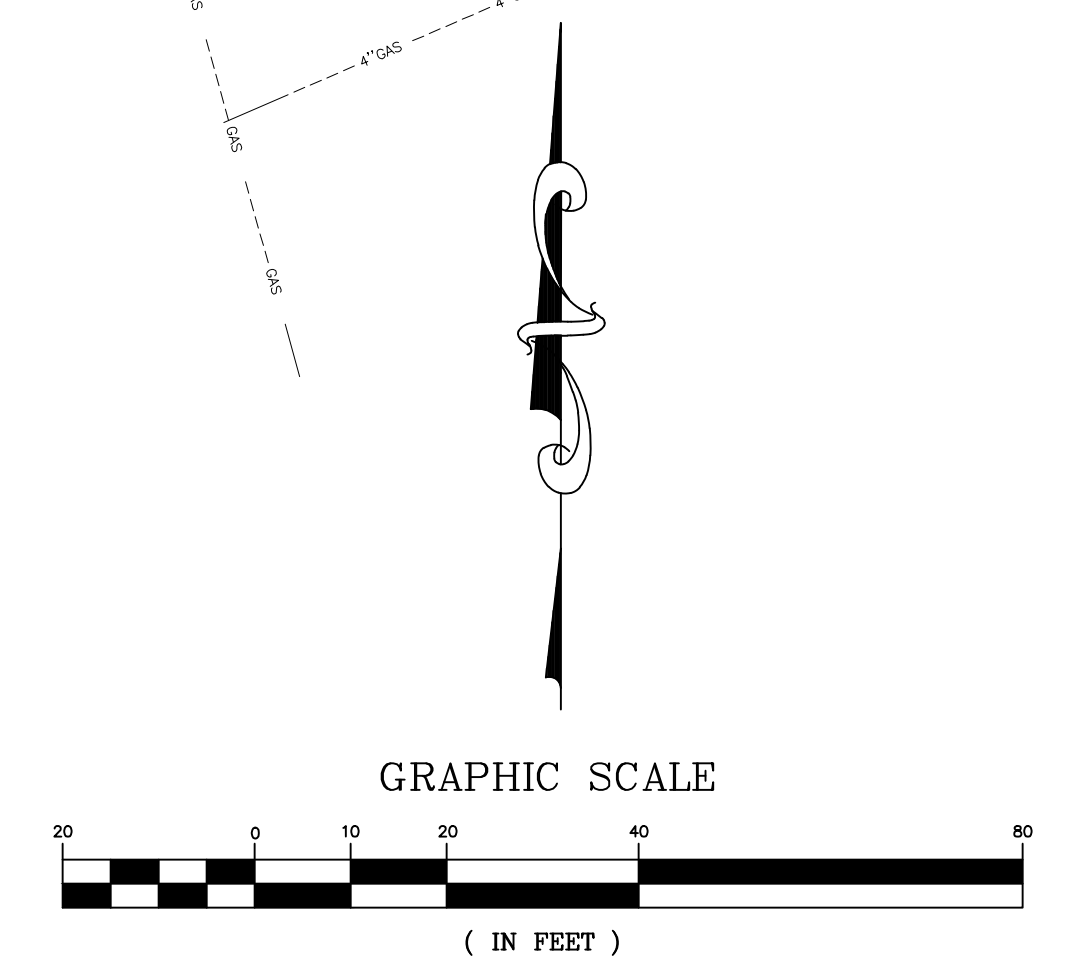

Copyright © 2015 BY FLORIDA ARCHITECTS, INC. ARCHITECT EXPRESSLY RESERVES HIS EXCLUSIVE COMMON LAW COPYRIGHT AND PROPERTY RIGHTS TO THESE DRAWINGS WHICH MAY NOT BE REPRODUCED, CHANGED OR COPIED IN ANY FORM OR MANNER, NOR ARE THEY TO BE ASSIGNED TO ANY PARTY WITHOUT THE ARCHITECT'S WRITTEN CONSENT.

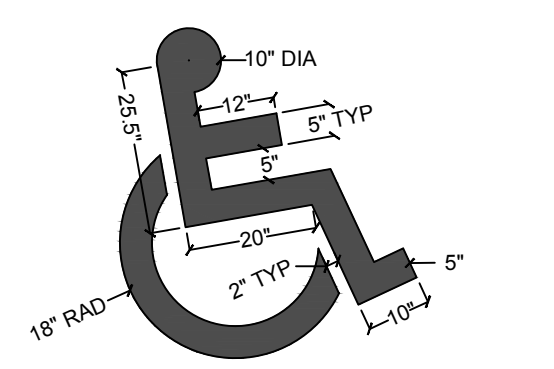
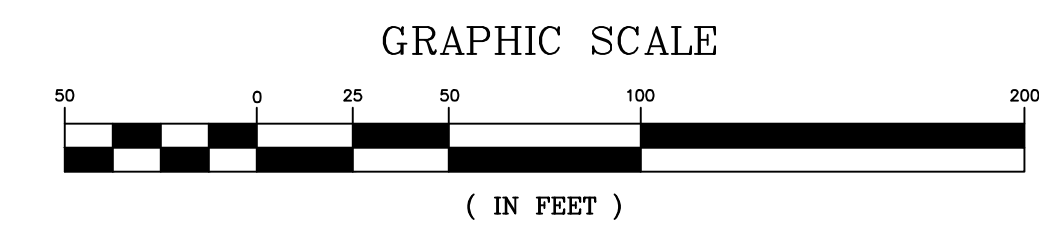
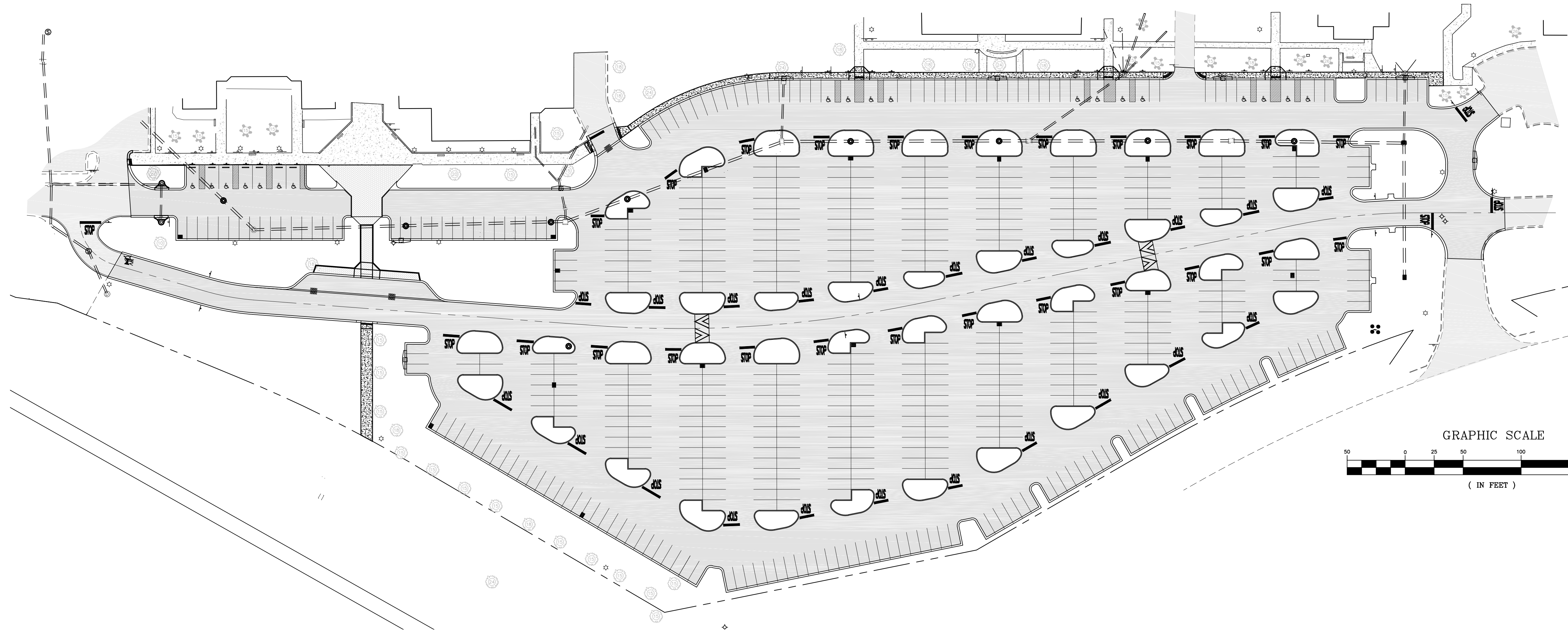

HANDICAPPED PERMIT PARKING ONLY
 SIGN-BLUE AND WHITE REFLECTIVE
 FILM ON ALUMINUM PANEL.
 SEE "FLORIDA HANDICAPPED
 ACCESSIBILITY CODE"

WHITE REFLECTIVE FILM 21TH BLACK
 OPAQUE LEGEND ON ALUMINUM
 PANEL
 F.S. 316.1955 (4)

PENALTY FOR ILLEGAL USE PER LOCAL
 ORDINANCE, BLACK LETTERING AND
 BORDER ON WHITE BACKGROUND ON
 ALUMINUM PANEL
 F.S. 316.1955 (5), 1996

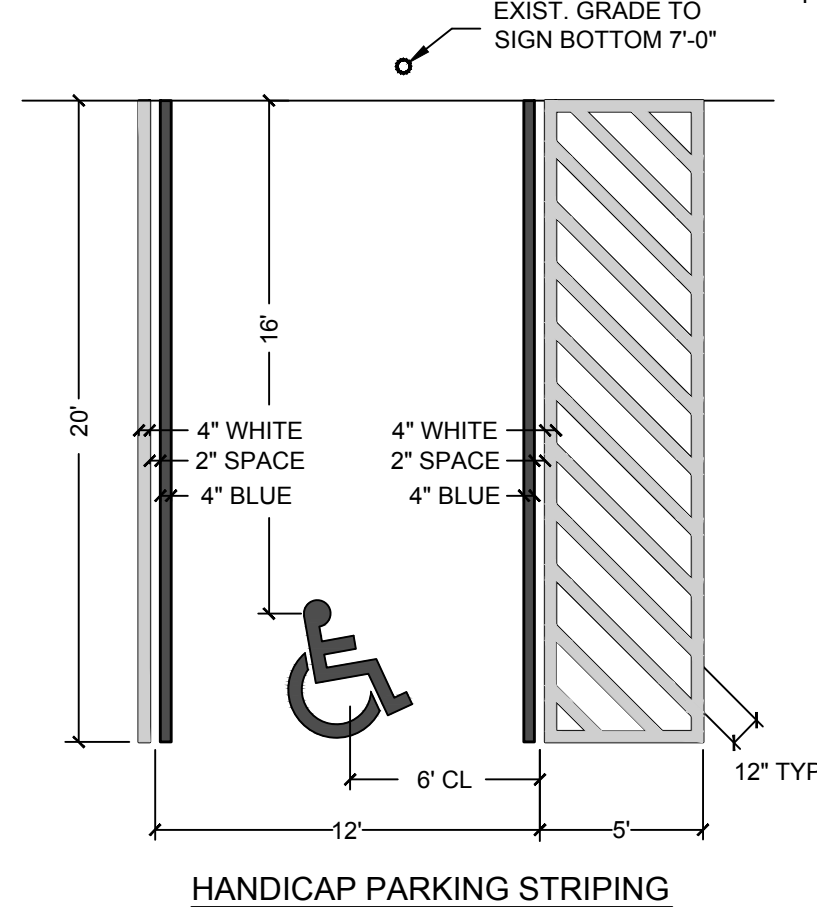
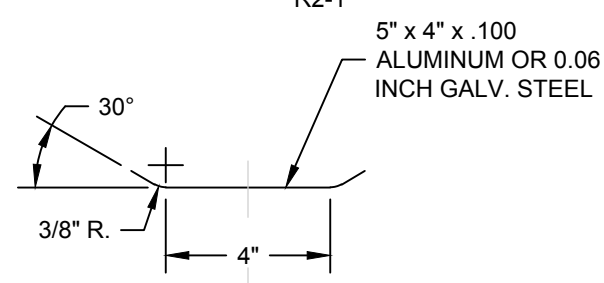
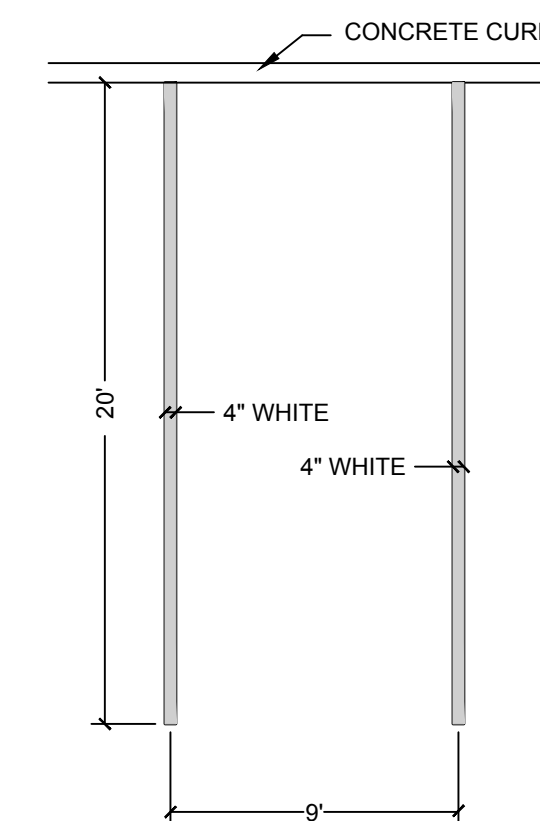
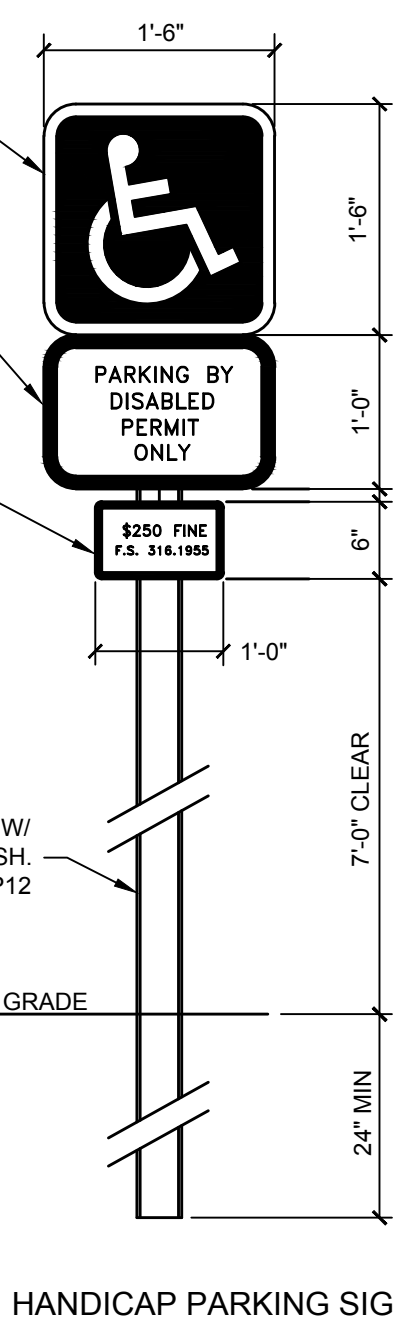

- NOTES:**
- * COLOR CONTRAST CHARACTERS AND SYMBOLS SHALL CONTRAST WITH THEIR BACKGROUND - EITHER LIGHT CHARACTERS ON A DARK BACKGROUND OR DARK CHARACTERS ON A LIGHT BACKGROUND.
 - EACH PARKING SPACE SHALL BE CONSPICUOUSLY OUTLINED IN BLUE PAINT, AND SHALL BE POSTED AND MAINTAINED WITH A PERMANENT, ABOVE-GRADE SIGN BEARING THE INTERNATIONAL SYMBOL OF ACCESSIBILITY OR THE CAPTION "PARKING BY DISABLED PERMIT ONLY" OR BEARING BOTH SUCH SYMBOL AND CAPTION. SUCH SIGNS SHALL NOT BE OBSCURED BY A VEHICLE PARKED IN THE SPACE. ALL HANDICAPPED PARKING SPACES MUST BE SIGNED AND MARKED IN ACCORDANCE WITH THE STANDARDS ADOPTED BY THE DEPARTMENT OF TRANSPORTATION.

DETAIL HANDICAP PARKING DETAILS
 SCALE: N.T.S.

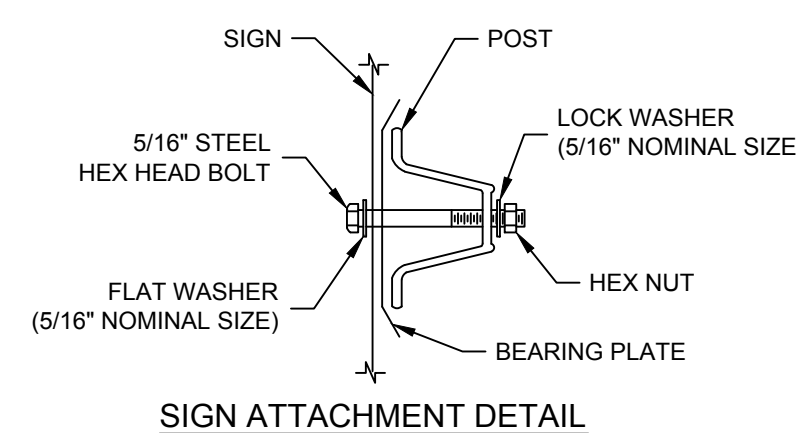
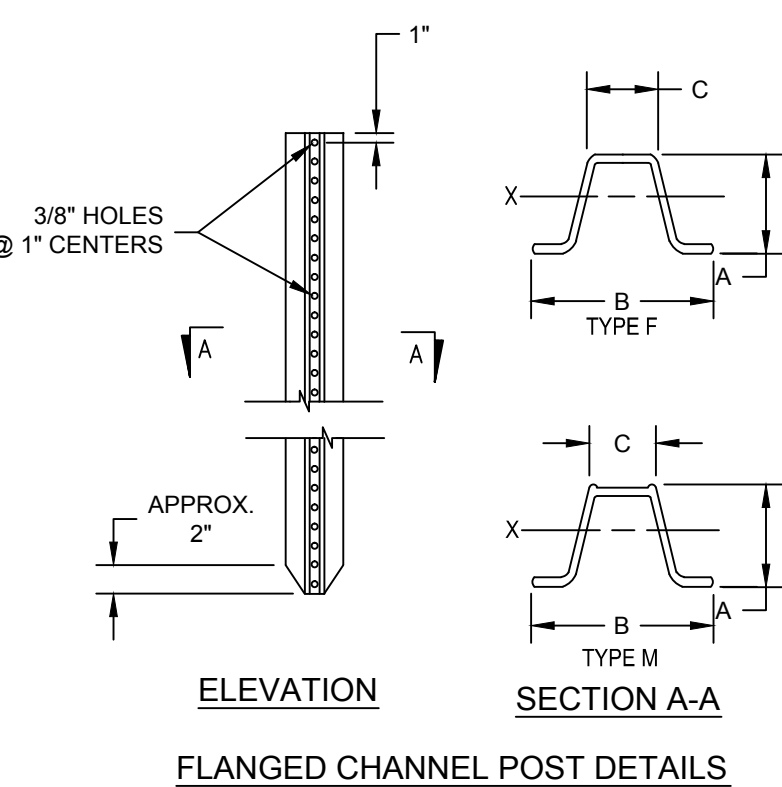

DETAIL HANDICAP PARKING SIGN
 SCALE: N.T.S.

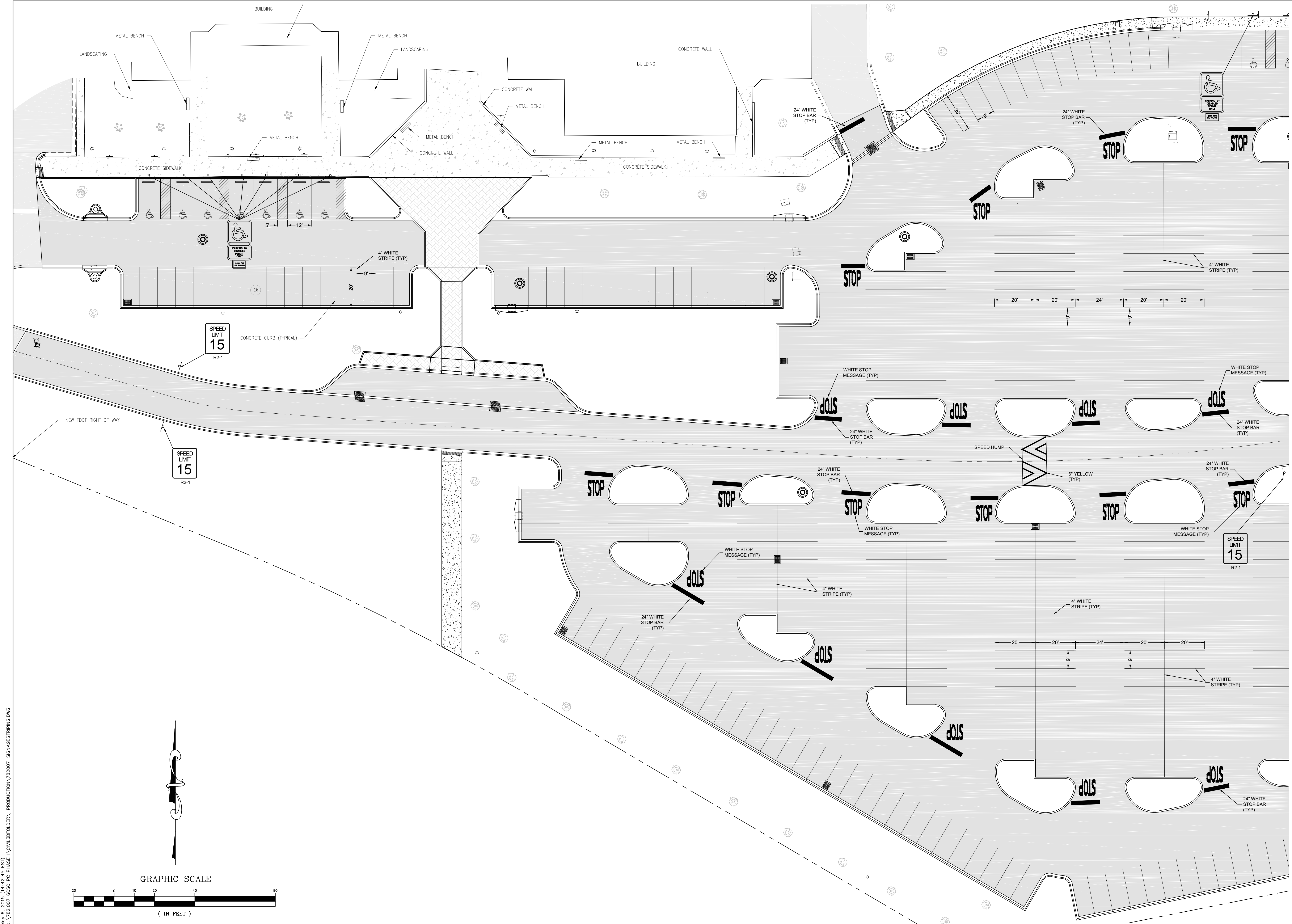

May 6, 2015 (14:42:46 EST)
 K:\7892_007_GCSG_PC_PHASE1\CIVIL3\FOLDER_V\PRODUCTION\782007_SIGNAGESTRIPING.DWG

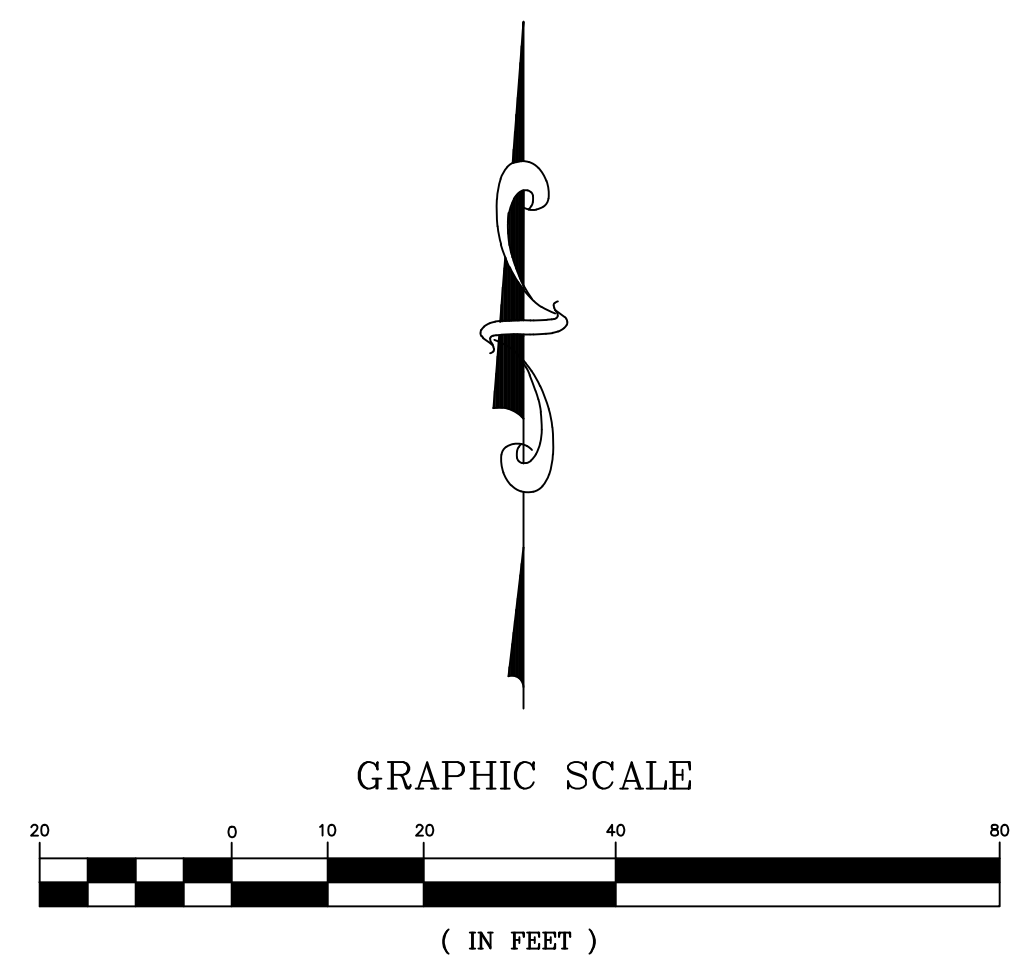

Copyright © 2015 BY FLORIDA ARCHITECTS, INC. ARCHITECT EXPRESSLY RESERVES HIS EXCLUSIVE COMMON LAW COPYRIGHT AND PROPERTY RIGHTS TO THESE DRAWINGS WHICH MAY NOT BE REPRODUCED, CHANGED OR COPIED IN ANY FORM OR MANNER, NOR ARE THEY TO BE ASSIGNED TO ANY PARTY WITHOUT THE ARCHITECT'S WRITTEN CONSENT.

May 6, 2015 (14:42:46 PST)
K:\7852.007_GCS_C_PC_PHASE1\CIVIL3\FOLDER_L\PRODUCTION\782007_SIGNAGESTRIPING.DWG

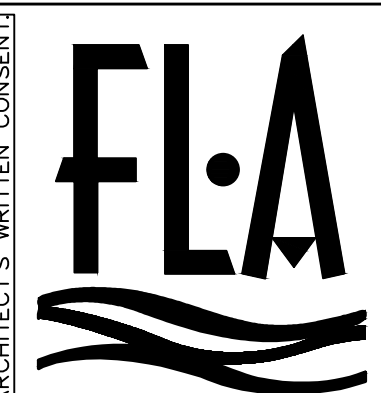
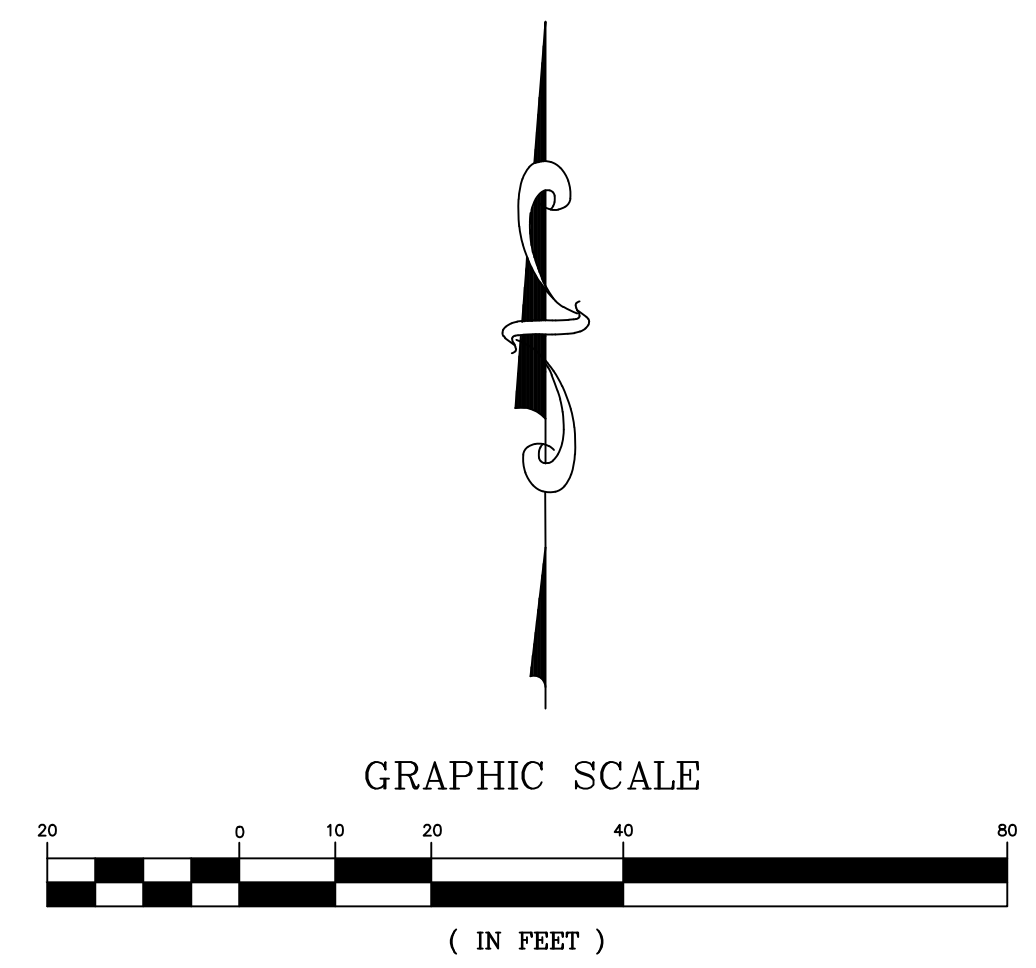
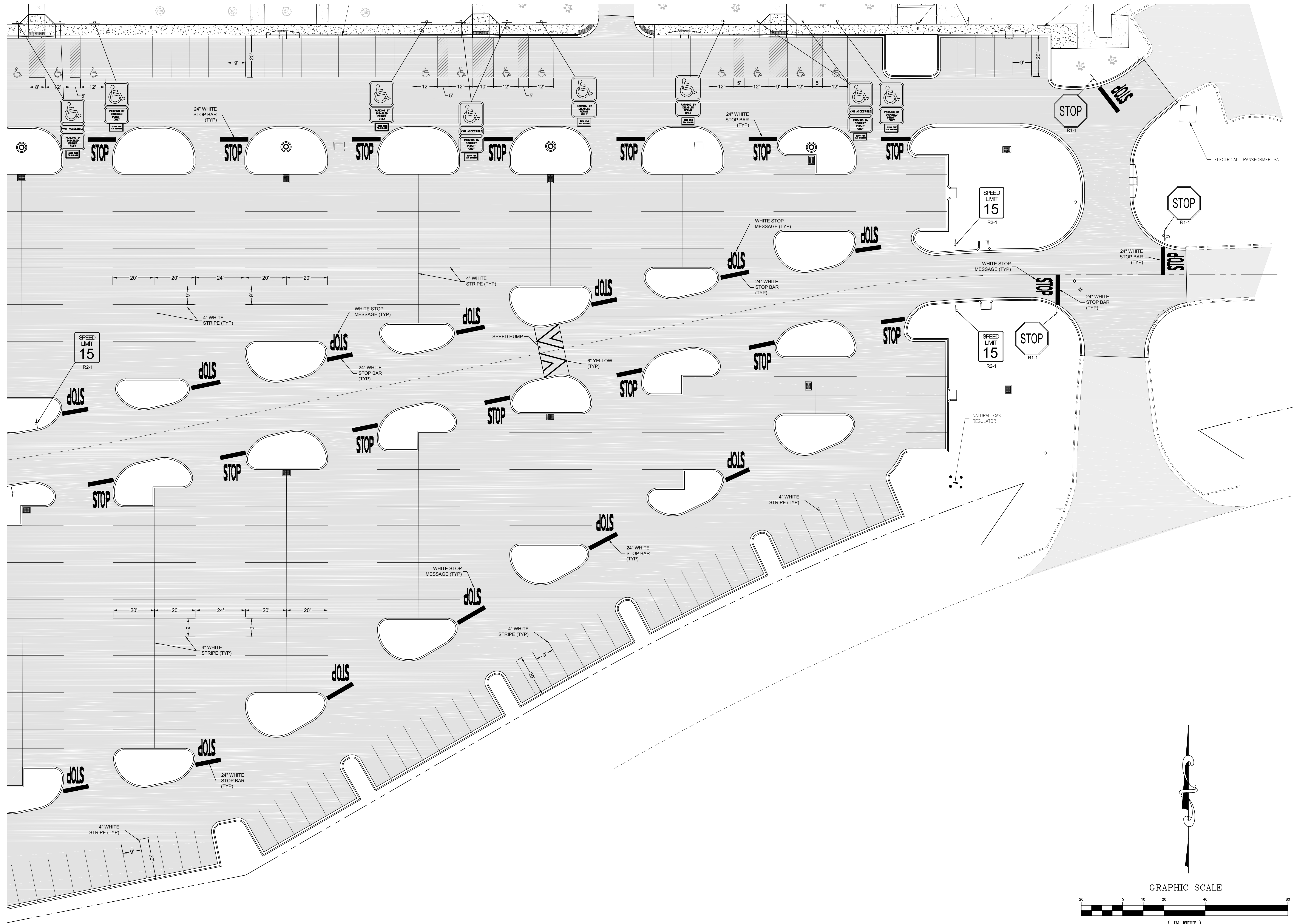

FLORIDA ARCHITECTS
LICENSE #AA0002730
648 Florida Avenue
Panama City, FL 32401
P 850/257-5400

JONATHAN SKLARSKI
FL. P.E. 67361

Principal in Charge
Joseph J. Sorci
Project Number:
4166-2
Date Issued:
5-7-2015
Drawn By:
B.R.
Checked By:
J.S.
Revisions:



SIGNAGE AND STRIPING PLAN
GULF COAST STATE COLLEGE
PHASE 1 CAMPUS
IMPROVEMENTS

BID DOCUMENTS
Sheet Number
C16

Copyright © 2015 BY FLORIDA ARCHITECTS, INC. ARCHITECT EXPRESSLY RESERVES HIS EXCLUSIVE COMMON LAW COPYRIGHT AND PROPERTY RIGHTS TO THESE DRAWINGS WHICH MAY NOT BE REPRODUCED, CHANGED OR COPIED IN ANY FORM OR MANNER, NOR ARE THEY TO BE ASSIGNED TO ANY PARTY WITHOUT THE ARCHITECT'S WRITTEN CONSENT.

STORMWATER POLLUTION PREVENTION PLAN

1.0 SITE DESCRIPTION

A. NATURE OF CONSTRUCTION ACTIVITY: THIS PROJECT CONSISTS OF THE DEMOLITION OF EXISTING PARKING AND RECONSTRUCTION OF PAVED PARKING, DRIVEWAYS, STORMWATER CONVEYANCE, SIDEWALKS AND LANDSCAPE ISLANDS.

B. SEQUENCE OF MAJOR SOIL DISTURBING ACTIVITIES: THE FOLLOWING SEQUENCE OF MAJOR ACTIVITIES SHALL BE FOLLOWED UNLESS THE CONTRACTOR CAN PROPOSE AN ALTERNATIVE THAT IS EQUAL OR BETTER AT CONTROLLING EROSION AND SEDIMENT AND IS APPROVED BY THE ENGINEER. THE DETAILED SEQUENCE FOR THE ENTIRE PROJECT CAN VARY SIGNIFICANTLY FROM CONTRACTOR TO CONTRACTOR. THE CONTRACTOR IS RESPONSIBLE FOR PROVIDING A DETAILED SEQUENCE OF CONSTRUCTION FOR ALL CONSTRUCTION ACTIVITIES IN SECTION 104 EROSION CONTROL PLANS.

FOR EACH CONSTRUCTION PHASE, INSTALL PERIMETER CONTROLS BEFORE BEGINNING OTHER WORK FOR THE CONSTRUCTION PHASE. REMOVE PERIMETER CONTROLS ONLY AFTER DISTURBED AREAS ARE STABILIZED.

C. AREA ESTIMATES
TOTAL SITE AREA: 72 AC.
TOTAL AREA DISTURBED: 9.1 AC.

D. RUNOFF DATA:
RUNOFF COEFFICIENT:
BEFORE: 0.30 (UNPAVED); 0.98 (PAVED)
DURING: FROM 0.30 TO 0.50 (UNPAVED); 0.30 TO 0.98 (PAVED)
AFTER: 0.30 (UNPAVED); 0.98 (PAVED)
SOIL DATA:

SEE ATTACHED GEOTECHNICAL REPORT

OUTFALL INFORMATION:
ALL DRAINAGE WILL CONNECT TO EXISTING OUTFALLS.

E. SITE MAP:
THE LOCATION MAP ON THE KEY SHEET DESCRIBES THE SITE. SPECIFICALLY:
DRAINAGE PATTERNS:
EXISTING DRAINAGE FLOWS GENERALLY TO LOCAL DRAINAGE NETWORKS OR DIRECTLY TO ADJACENT WOODS AND ULTIMATELY TO THE GULF OF MEXICO.

APPROXIMATE SLOPES: 0 TO 5 PERCENT
AREA OF SOIL DISTURBANCE: PROPOSED SITE, DRIVEWAYS, PARKING, AND DEMOLISHED FACILITIES. AREAS NOT TO BE DISTURBED: OUTSIDE OF EXISTING PROJECT LIMITS.

LOCATIONS OF TEMPORARY CONTROLS:
TEMPORARY STABILIZATION PRACTICES WILL BE DESCRIBED IN THE NARRATIVE.
LOCATIONS OF PERMANENT CONTROLS:
LOCATION OF PERMANENT STABILIZATION IS SHOWN ON THE PLANS.
AREAS TO BE STABILIZED:
TEMPORARY STABILIZATION PRACTICES ARE SHOWN IN THE SAME LOCATION AS THE TEMPORARY CONTROLS MENTIONED ABOVE. PERMANENT STABILIZATION IS SHOWN ON THE PLAN SHEETS.

SURFACE WATERS: NONE
DISCHARGE POINTS TO SURFACE WATERS: NO NEW DISCHARGE POINTS.

F. RECEIVING WATERS:
RUNOFF FROM THE EXISTING DRAINAGE SYSTEM DISCHARGES THROUGH TREATMENT FACILITIES TO ST. ANDREW BAY.

2.0 CONTROLS

A. EROSION AND SEDIMENT CONTROLS:
THE FOLLOWING DISCUSSION DEFINES GENERAL GUIDELINES FOR THE SEQUENCES OF CONSTRUCTION AND THE USE OF STABILIZATION AND STRUCTURAL PRACTICES. THE CONTRACTOR IS ALSO RESPONSIBLE FOR DOCUMENTING THIS PORTION OF THE SWPPP IN THE SECTION 104 EROSION CONTROL PLAN. ALL ITEMS REPRESENTED IN THE FOLLOWING DISCUSSION ARE TREATED IN DETAIL IN THE "FLORIDA DEPARTMENT OF TRANSPORTATION STANDARD SPECIFICATIONS FOR ROAD AND BRIDGE CONSTRUCTION" (2010). THE CONTRACTOR SHALL GENERATE AN IMPLEMENTATION SCHEDULE FOR EACH PHASE OF CONSTRUCTION OPERATIONS OR ACTIVITIES.

1. STABILIZATION PRACTICES:
IN THE SECTION 104 EROSION CONTROL PLAN, THE CONTRACTOR SHALL DESCRIBE THE STABILIZATION PRACTICES PROPOSED TO CONTROL EROSION. THE CONTRACTOR SHALL INITIATE ALL STABILIZATION MEASURES AS SOON AS PRACTICAL BUT IN NO CASE IN MORE THAN 7 DAYS. THE STABILIZATION PRACTICES SHALL INCLUDE AT LEAST THE FOLLOWING, UNLESS OTHERWISE APPROVED BY THE ENGINEER.

PERMANENT:
SOD IN ACCORDANCE WITH SPECIFICATION SECTION 575. ALL STABILIZATION PRACTICES SHALL BE INITIATED AS SOON AS PRACTICABLE IN PORTIONS OF THE SITE WHERE CONSTRUCTION ACTIVITIES ARE TEMPORARILY OR PERMANENTLY CEASED. THE CONTRACTOR IS ALSO RESPONSIBLE FOR DOCUMENTING THIS PORTION OF THE SWPPP ON THE SECTION 104 EROSION CONTROL PLAN.

TEMPORARY:
SEED AND MULCH AND SOD IN ACCORDANCE WITH SPECIFICATION SECTION 104.

2. STRUCTURAL PRACTICES:
ALL SEDIMENT CONTROLS SHALL BE IN PLACE PRIOR TO ANY SOIL DISTURBING ACTIVITY UPSTREAM OF THE CONTROL. THE CONTRACTOR IS ALSO RESPONSIBLE FOR DOCUMENTING THIS PORTION OF THE SWPPP ON THE SECTION 104 EROSION CONTROL PLAN.

TEMPORARY:
SEDIMENT BARRIERS, TURBIDITY BARRIERS AND INLET PROTECTION

B. STORMWATER MANAGEMENT
STORMWATER WILL BE CONVEYED THROUGH CLOSED CONVEYANCE SYSTEMS AND DITCHES TO LOCAL STORMWATER TREATMENT FACILITIES.

C. OTHER CONTROLS
1. WASTE DISPOSAL:
IN THE SECTION 104 EROSION CONTROL PLAN, THE CONTRACTOR SHALL DESCRIBE PROPOSED METHODS TO PREVENT THE DISCHARGE OF SOLID MATERIALS, INCLUDING BUILDING MATERIALS, TO WATERS OF THE UNITED STATES. THE PROPOSED METHODS SHALL INCLUDE AT LEAST THE FOLLOWING, UNLESS OTHERWISE APPROVED BY THE ENGINEER.

PROVIDE LITTER CONTROL AND COLLECTION WITHIN THE PROJECT DURING CONSTRUCTION ACTIVITIES.

DISPOSE OF ALL FERTILIZER OR OTHER CHEMICAL CONTAINERS ACCORDING TO EPA'S STANDARD PRACTICES AS DETAILED BY THE MANUFACTURER.

DISPOSE OF SOLID MATERIALS INCLUDING BUILDING AND CONSTRUCTION MATERIALS OFFSITE BUT NOT IN SURFACE WATERS OR WETLANDS.

2. OFFSITE VEHICLE TRACKING:
IN THE SECTION 104 EROSION CONTROL PLAN, THE CONTRACTOR SHALL DESCRIBE THE PROPOSED METHODS FOR MINIMIZING OFFSITE VEHICLE TRACKING OF SEDIMENTS AND GENERATING DUST. UNLESS APPROVED BY THE ENGINEER, THE PROPOSED METHODS SHALL INCLUDE AT LEAST THE FOLLOWING.

COVERING LOADED HAUL TRUCKS WITH TARPAULINS.

REMOVING EXCESS DIRT FROM ROADS DAILY.

STABILIZING CONSTRUCTION ENTRANCES ACCORDING TO DESIGN STANDARD 106.

USING ROADWAY SWEEPERS DURING DUST GENERATING ACTIVITIES SUCH AS EXCAVATION AND MILLING OPERATIONS.

3. STATE AND LOCAL REGULATIONS FOR WASTE DISPOSAL, SANITARY SEWER OR SEPTIC TANK
IN THE SECTION 104 EROSION CONTROL PLAN, THE CONTRACTOR SHALL DESCRIBE THE PROPOSED PROCEDURES TO COMPLY WITH APPLICABLE STATE AND LOCAL REGULATIONS FOR WASTE DISPOSAL, SANITARY SEWER AND SEPTIC SYSTEMS.

4. FERTILIZERS AND PESTICIDES:
FERTILIZERS SHALL BE APPLIED ACCORDING TO SPECIFICATION SECTION 570 OR 577 OF THE FOOT STANDARD SPECIFICATIONS. THE CONTRACTOR IS ALSO RESPONSIBLE FOR DOCUMENTING THIS PORTION OF THE SWPPP ON THE SECTION 104 EROSION CONTROL PLAN.

5. TOXIC SUBSTANCES:
IN THE SECTION 104 EROSION CONTROL PLAN, THE CONTRACTOR SHALL PROVIDE A LIST OF TOXIC SUBSTANCES THAT ARE LIKELY TO BE USED ON THE JOB AND PROVIDE A PLAN ADDRESSING THE GENERATION, APPLICATION, MIGRATION, STORAGE AND DISPOSAL OF THESE SUBSTANCES.

3.0 MAINTENANCE:

Table with 3 columns: PROPOSED REPLACEMENT ITEM, MAINTENANCE, INTERVAL. Rows include SILT FENCE, INLET PROTECTION.

THE CONTRACTOR IS ALSO RESPONSIBLE FOR DOCUMENTING THIS PORTION OF THE SWPPP ON THE SECTION 104 EROSION CONTROL PLAN

4.0 INSPECTIONS

QUALIFIED PERSONNEL SHALL INSPECT THE FOLLOWING ITEMS AT LEAST ONCE EVERY SEVEN CALENDAR DAYS AND WITHIN 24 HOURS OF THE END OF A STORM THAT IS 0.5 INCHES OR GREATER. THE ENGINEER SHALL BE RESPONSIBLE FOR COMPLETING THE WEEKLY INSPECTION REPORT FORM AND SUBMISSION OF THE FORM TO THE FDOT CENTRAL OFFICE ON A MONTHLY BASIS. WHERE SITES HAVE BEEN FINALLY STABILIZED, INSPECTIONS SHALL BE CONDUCTED AT LEAST ONCE EVERY MONTH.

- POINTS OF DISCHARGE TO WATERS OF THE UNITED STATES
- DISTURBED AREAS OF THE SITE THAT HAVE NOT BEEN FINALLY STABILIZED
- STRUCTURAL CONTROLS
- AREAS USED FOR STORAGE OF MATERIALS THAT ARE EXPOSED TO PRECIPITATION
- LOCATIONS WHERE VEHICLES ENTER OR EXIT THE SITE

5.0 NON-STORMWATER DISCHARGES

THE CONTRACTOR IS ALSO RESPONSIBLE FOR DOCUMENTING THIS PORTION OF THE SWPPP ON THE SECTION 104 EROSION CONTROL PLAN. IF CONTAMINATED SOIL OR GROUNDWATER IS ENCOUNTERED, CONTACT THE PROJECT ADMINISTRATOR AND ENGINEER OF RECORD IMMEDIATELY.

PHASING OF IMPLEMENTATION

PHASE I - INSTALLATION OF ENVIRONMENTAL CONTROL FEATURES

ENVIRONMENTAL CONTROL FEATURES AS PROVIDED IN PLANS QUANTITIES ARE TO BE INSTALLED THROUGHOUT THE CONSTRUCTION LIMITS, AT ENVIRONMENTALLY SENSITIVE AREAS AS SHOWN ON THE PLANS, OR AT AREAS AS DIRECTED BY THE PROJECT ADMINISTRATOR. THESE FEATURES INCLUDE, BUT ARE NOT LIMITED TO, SILT FENCE, SYNTHETIC BALES, ETC.

PHASE II - SITE WORK OPERATIONS

SITE WORK SHALL BE DONE AS INDICATED ON THE PLANS.

PHASE III - DRAINAGE SYSTEM OR STRUCTURE ENVIRONMENTAL CONTROL FEATURES

ENVIRONMENTAL CONTROL FEATURES AS PROVIDED IN PLANS ARE TO BE INSTALLED AT ALL AREAS OF EXCAVATION OR FILL FOR DRAINAGE SYSTEM OR STRUCTURE CONSTRUCTION PRIOR TO SUCH EXCAVATION OR FILL. ALL STREAMS OR DITCHES ARE TO BE PROTECTED FROM EROSION OR SILTATION BY METHODS DETAILED IN THE STANDARD INDICES. THESE INCLUDE SILT FENCE, SYNTHETIC BALES, ETC.

PHASE IV - MAINTENANCE OF ENVIRONMENTAL CONTROL FEATURES

ALL ENVIRONMENTAL CONTROL FEATURES ARE TO BE MAINTAINED THROUGHOUT THE LIFE OF THE PROJECT AS NECESSARY FOR THE VARIOUS CONSTRUCTION PHASES. THE CONTRACTOR MUST INSURE THAT ALL OF THESE FEATURES FUNCTION PROPERLY AT ALL TIMES.

GENERAL NOTES

- 1. THE CONTRACTOR MAY CONSTRUCT THE PROJECT IN SEGMENTS BUT EACH OF THE ABOVE PHASES MUST BE FOLLOWED FOR EACH SEGMENT.
2. ALL EROSION AND MATERIAL DEPOSITS MUST BE CONTAINED WITHIN THE PROJECT LIMITS.

STORMWATER SYSTEM MAINTENANCE NOTES:

- 1. CONTRACTOR SHALL STAGE AND TIME CONSTRUCTION TO MINIMIZE THE SIZE OF EXPOSED SOIL AREAS AND THE TIME BETWEEN EXPOSING THE SOIL AREA AND FINISHING THE SOIL AREA.
2. IT SHALL BE THE RESPONSIBILITY OF THE CONTRACTOR PERFORMING A TASK TO PROVIDE EROSION CONTROL UNLESS ANOTHER PARTY HAS BEEN PREVIOUSLY SPECIFIED AS RESPONSIBLE FOR THE EROSION CONTROL ASSOCIATED WITH THAT TASK.
3. THE CONTRACTOR IS TO PROVIDE EROSION CONTROL/ SEDIMENTATION BARRIER (HAY BALES, SILT FENCE, TURBIDITY BARRIER, OR AS SPECIFIED IN THE CONSTRUCTION DRAWINGS) TO PREVENT SILTATION OF ADJACENT PROPERTY, STREETS, STORM SEWERS, WATERWAYS, AND WETLAND OR JURISDICTIONAL AREAS.
4. CONTRACTOR SHALL PLACE STRAW, MULCH, OR OTHER SUITABLE MATERIAL ON GROUND IN AREAS WHERE CONSTRUCTION-RELATED TRAFFIC IS TO ENTER AND EXIT SITE.
5. IF WIND EROSION BECOMES SIGNIFICANT DURING CONSTRUCTION, THE CONTRACTOR SHALL STABILIZE THE AREA USING SPRINKLING IRRIGATION OR OTHER ACCEPTABLE METHODS.
6. ALL NEW DRAINAGE PIPE SHALL BE AS INDICATED ON PLANS OR APPROVED EQUAL.
7. CONTRACTOR SHALL BE RESPONSIBLE FOR CONSTRUCTION MONITORING, NOTICE OF COMMENCEMENT, AND AS-BUILT CERTIFICATION.
8. CONTRACTOR SHALL PREPARE A DEWATERING AND STOCKPILE PLAN AS PART OF THE NPDES PERMIT PROCESS.
9. THE OWNER IS TO MAINTAIN THE STORMWATER SYSTEM PER THE OPERATION AND MAINTENANCE PLAN.



FLORIDA ARCHITECTS LICENSE #AA0002730 648 Florida Avenue Panama City, FL 32401 P 850/257-5400

JONATHAN SKLAREKI FL. P.E. 67361

Principal in Charge Joseph J. Sorci Project Number: 4166-2 Date Issued: 5-7-2015 Drawn By: BWR Checked By: J.S. Revisions:



PREBLE-RISH, INC.

GULF COAST STATE COLLEGE PHASE 1 CAMPUS IMPROVEMENTS

STORMWATER POLLUTION PREVENTION PLAN

BID DOCUMENTS Sheet Number C17

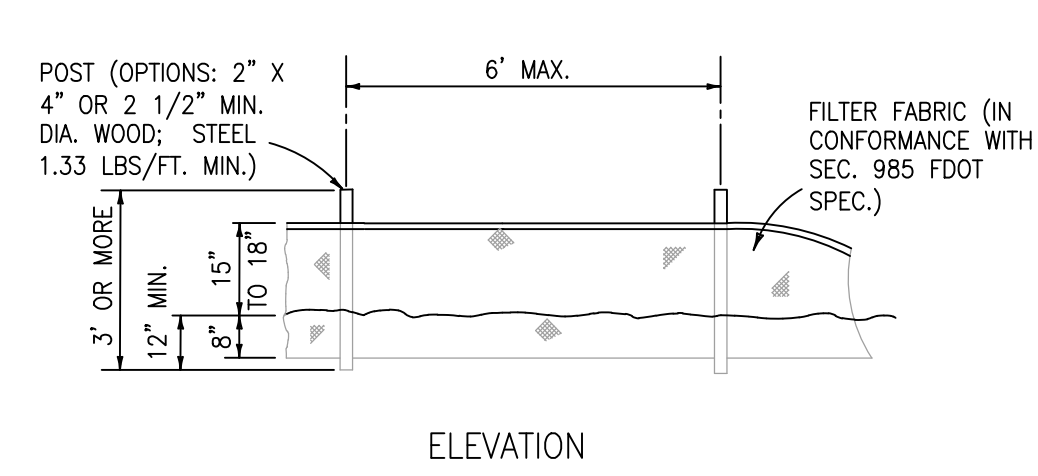

NOTE: SILT FENCE TO BE PAID FOR UNDER THE CONTRACT UNIT PRICE FOR STAKED SILT FENCE (LF).

TYPE III SILT FENCE

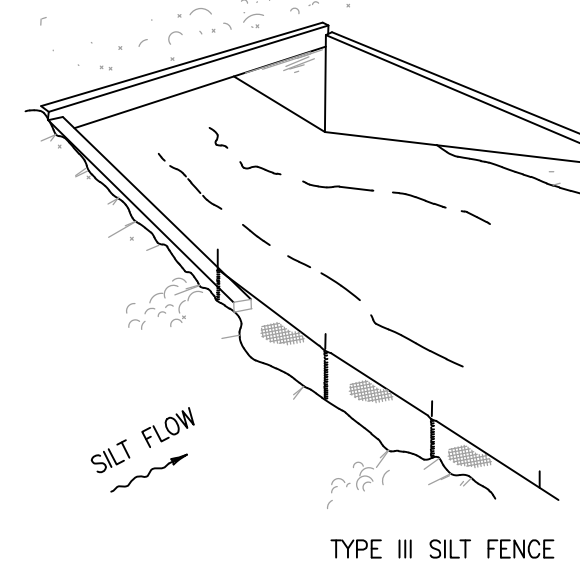

TYPE III SILT FENCE

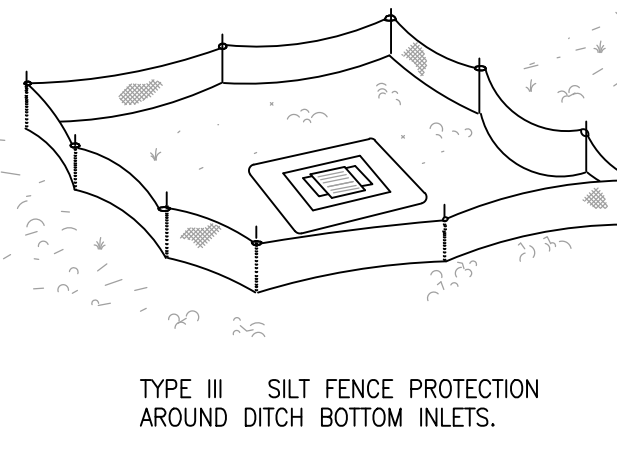

TYPE III SILT FENCE PROTECTION AROUND DITCH BOTTOM INLETS.

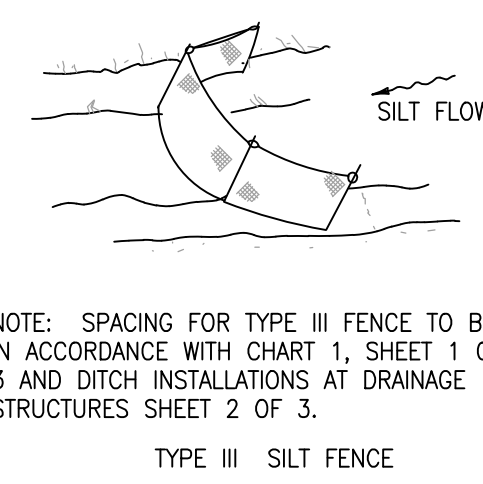

TYPE III SILT FENCE

DO NOT DEPLOY IN A MANNER THAT SILT FENCES WILL ACT AS A DAM ACROSS PERMANENT FLOWING WATERCOURSES. SILT FENCES ARE TO BE USED AT UPLAND LOCATIONS AND TURBIDITY BARRIERS USED AT PERMANENT BODIES OF WATER.

SILT FENCE APPLICATIONS

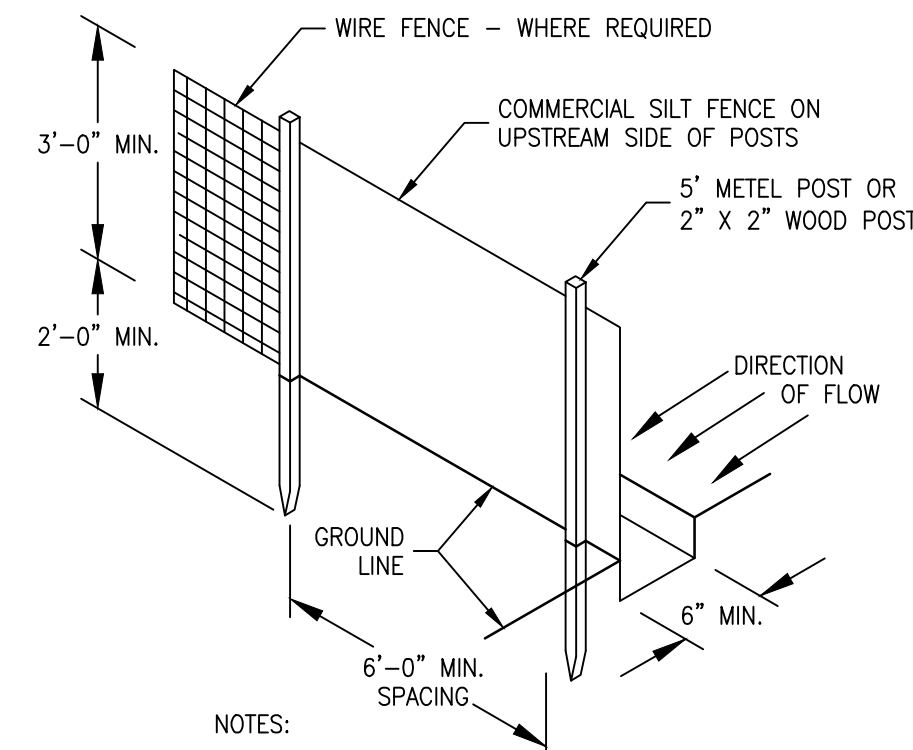

NOTES:

1. DIG TRENCH 6" DEEP.
2. LAY IN FABRIC TO BOTTOM OF TRENCH.
3. BACK TRENCH, COVERING FABRIC.

DETAIL SILT FENCE

SCALE: N.T.S.

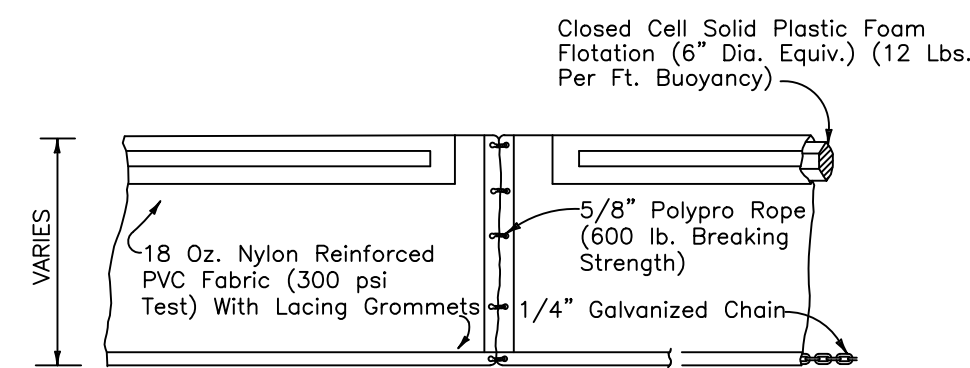

TYPE I

DETAIL TURBIDITY CURTAIN

SCALE: N.T.S.

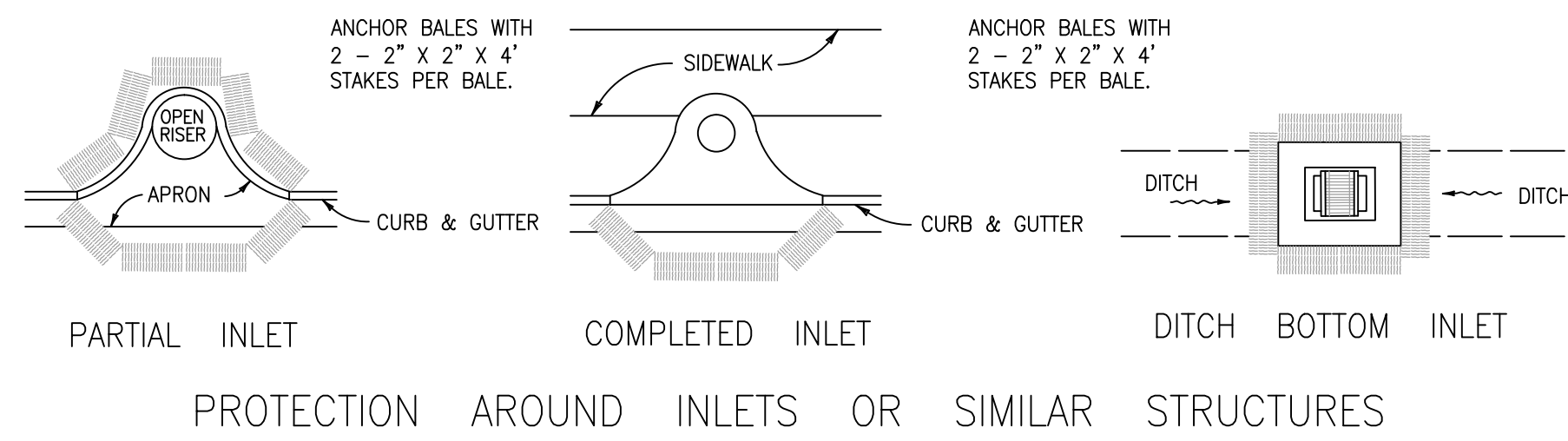

PROTECTION AROUND INLETS OR SIMILAR STRUCTURES

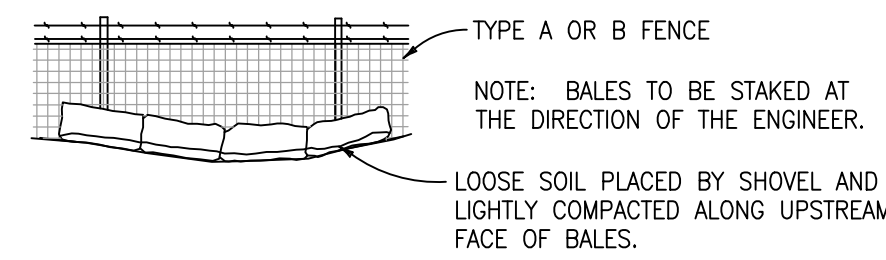

BALES BACKED BY FENCE

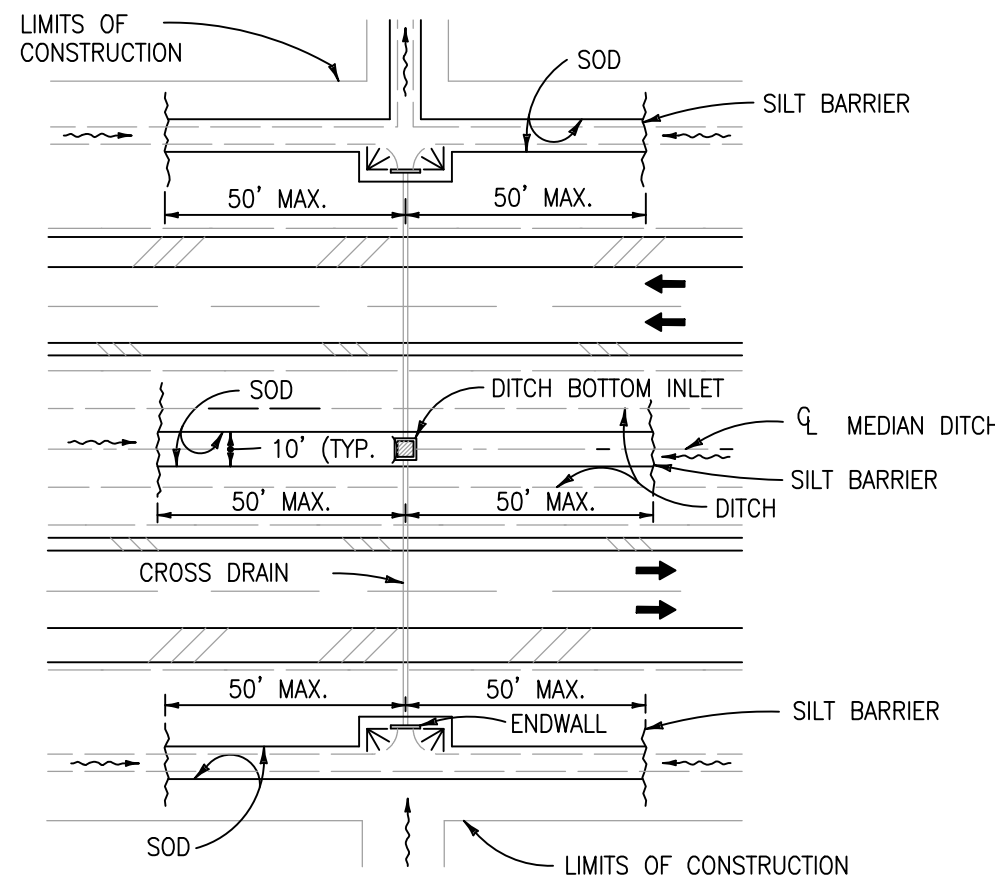

DITCH INSTALLATIONS AT DRAINAGE STRUCTURES

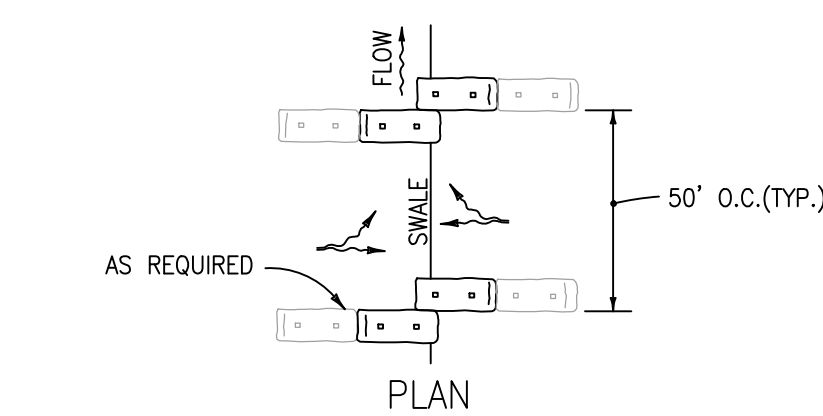

BARRIER FOR PAVED DITCH

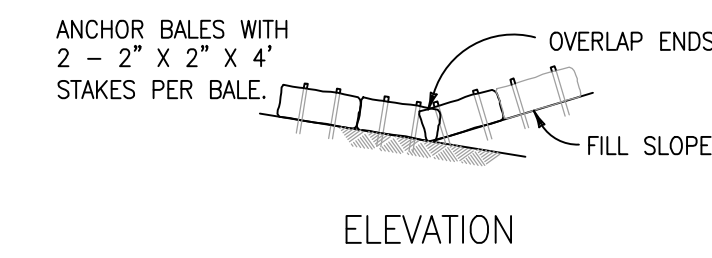

ELEVATION

TO BE USED AT SELECTED SITES WHERE THE NATURAL GROUND SLOPES TOWARD THE TOE OF SLOPE

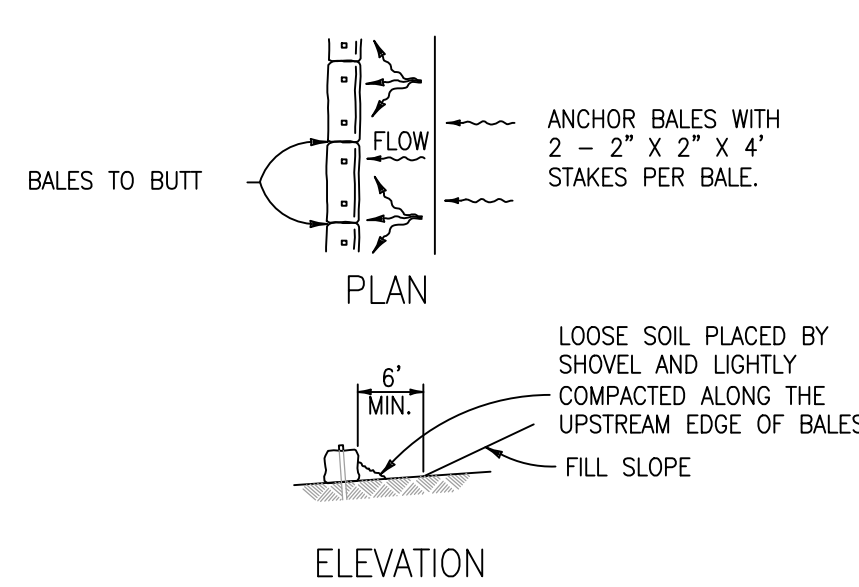

ELEVATION

TO BE USED AT SELECTED SITES WHERE THE NATURAL GROUND SLOPES AWAY FROM THE TOE OF SLOPE

BARRIERS FOR FILL SLOPES

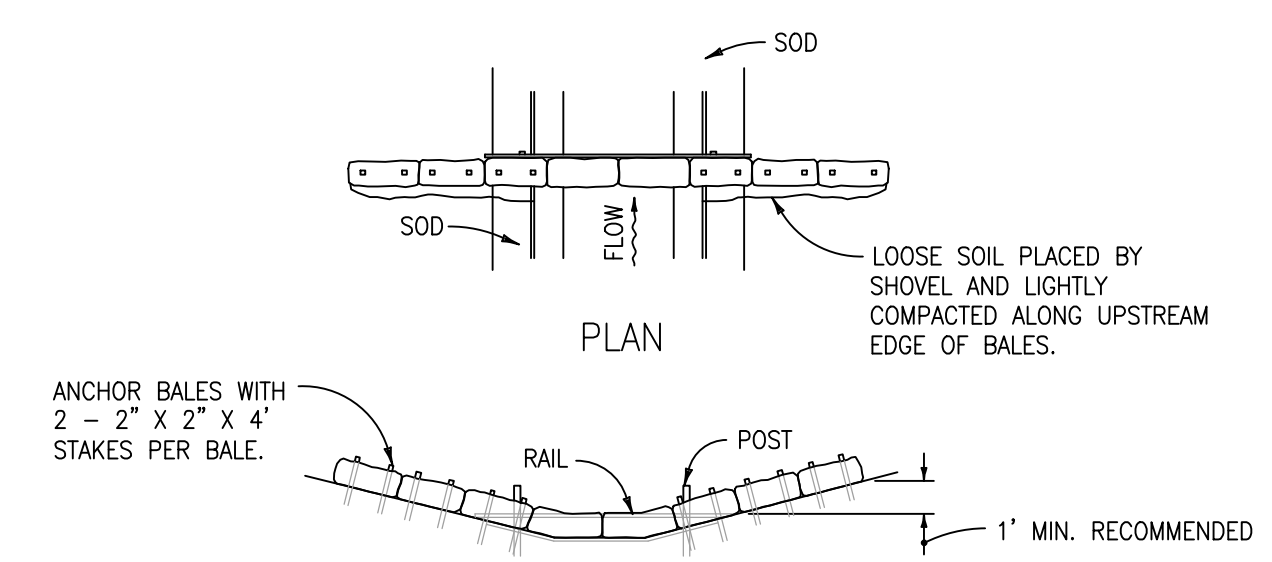

ELEVATION

SPACING: BALE BARRIERS FOR PAVED DITCHES SHOULD BE SPACED IN ACCORDANCE WITH THE CHART BELOW

BARRIER FOR PAVED DITCH

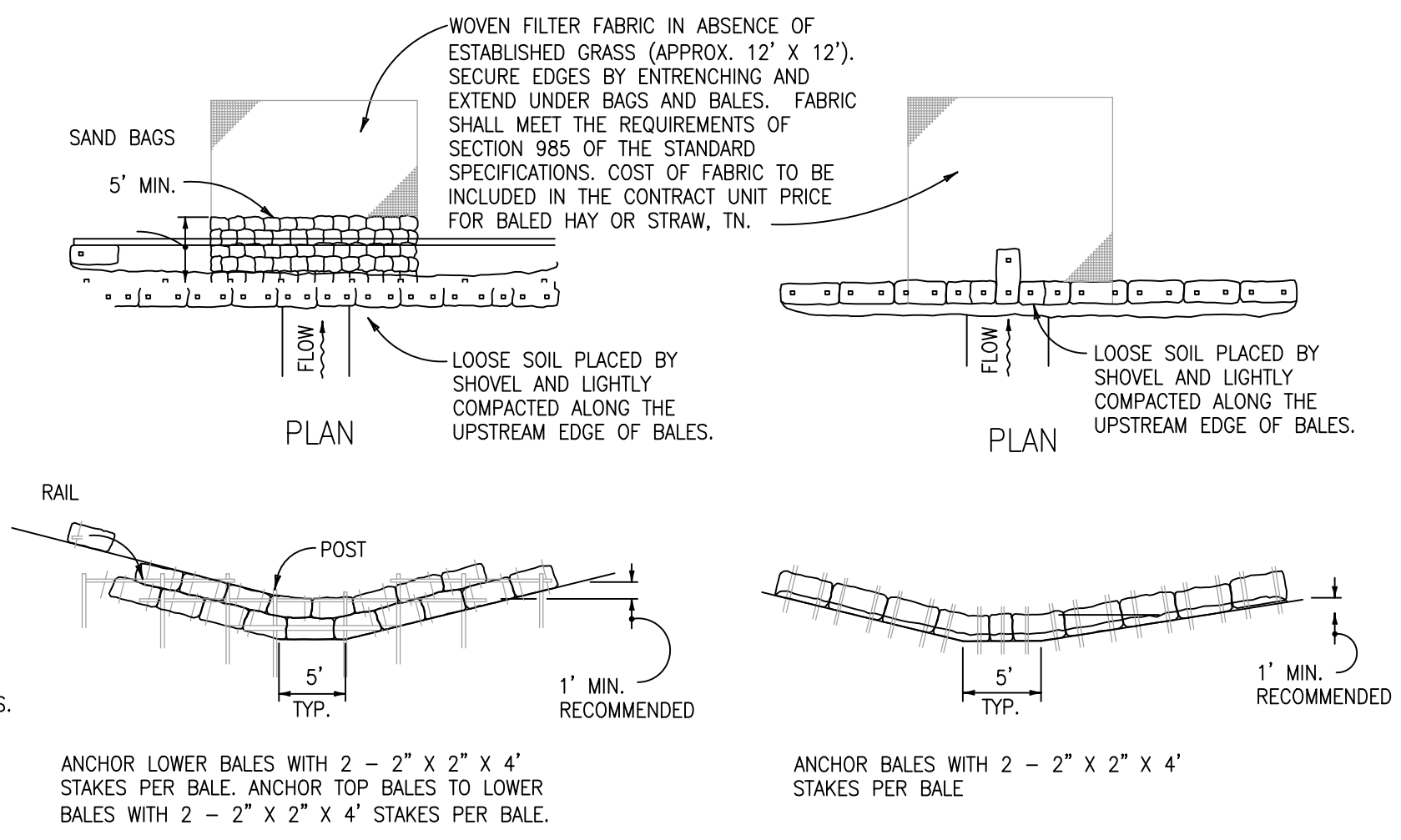

ELEVATION

APPLICATION AND SPACING: THE USE OF TYPES I & II BALE BARRIERS SHOULD BE LIMITED TO THE CONDITIONS OUTLINED IN THE CHART BELOW.

TYPE II

ELEVATION

TYPE I

BARRIER FOR UNPAVED DITCHES

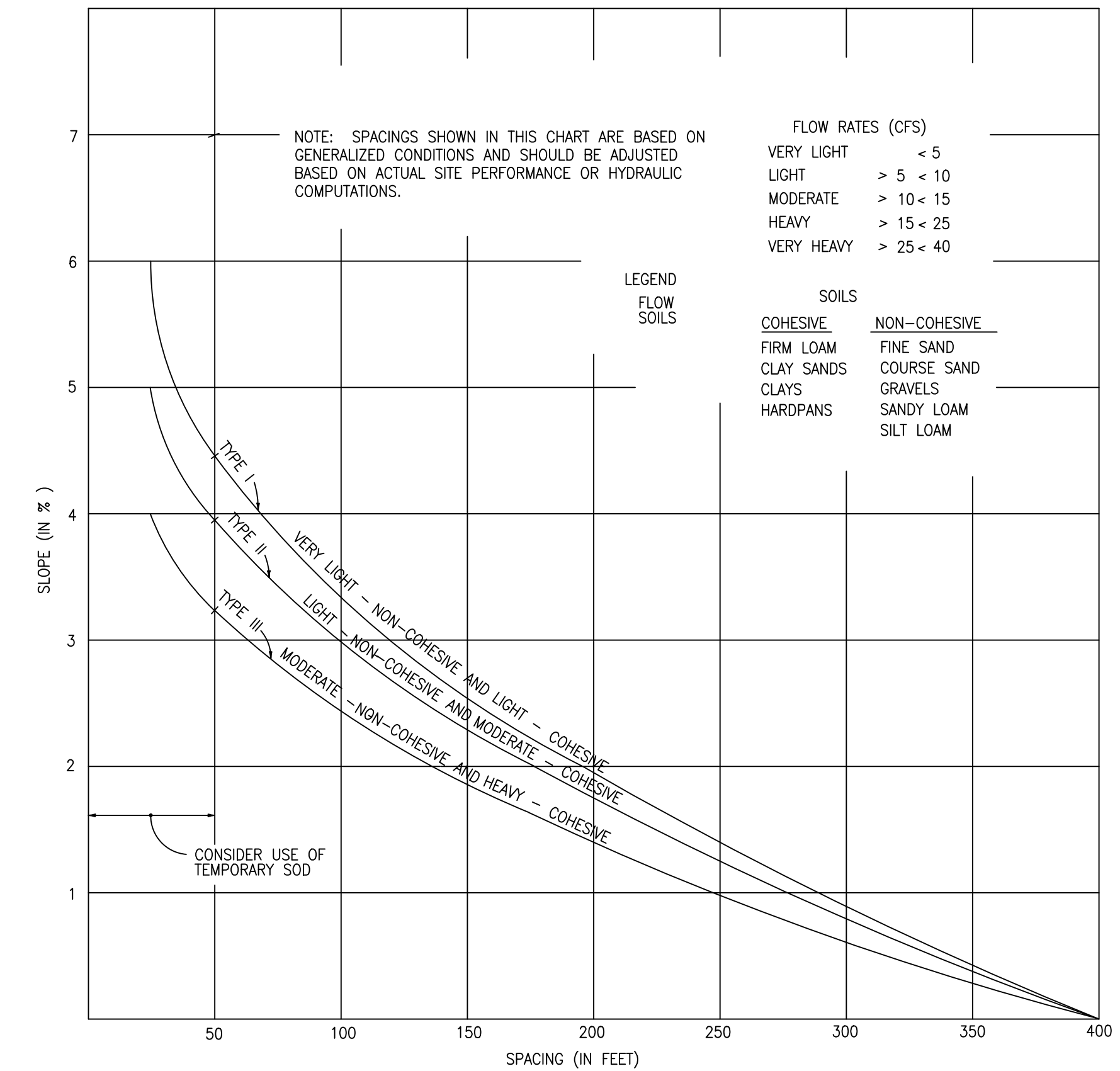

CHART I

RECOMMENDED SPACING FOR TYPE I AND TYPE II HAY BALE BARRIERS, AND TYPE III SILT FENCES

DEWATERING NOTES

1. THE FACILITY IS AUTHORIZED TO DISCHARGE PRODUCED GROUND WATER FROM ANY NON-CONTAMINATED SITE ACTIVITY WHICH DISCHARGES BY A POINT SOURCE TO SURFACE WATERS OF THE STATE, AS DEFINED IN CHAPTER 62-620, F.A.C., ONLY IF THE REPORTED VALUES FOR THE PARAMETERS LISTED IN TABLE 1 DO NOT EXCEED ANY OF THE LISTED SCREENING VALUES. BEFORE DISCHARGE OF PRODUCED GROUND WATER CAN OCCUR FROM SUCH SITES, ANALYTICAL TESTS ON SAMPLES OF THE PROPOSED UNTREATED DISCHARGE WATER SHALL BE PERFORMED TO DETERMINE IF CONTAMINATION EXISTS.
2. MINIMUM REPORTING REQUIREMENTS FOR ALL PRODUCED GROUND WATER DISCHARGES. THE EFFLUENT SHALL BE SAMPLED BEFORE THE COMMENCEMENT OF DISCHARGE, AGAIN WITHIN THIRTY (30) DAYS AFTER COMMENCEMENT OF DISCHARGE, AND THEN ONCE EVERY SIX (6) MONTHS FOR THE LIFE OF THE PROJECT. SAMPLES SHALL BE TAKEN PRIOR TO ACTUAL DISCHARGE OR MIXING WITH THE RECEIVING WATERS. THE EFFLUENT SHALL BE SAMPLED FOR THE PARAMETERS LISTED IN TABLE 1.

Table 1

Parameter	Screening Values for Discharges into	
	Fresh Waters	Coastal Waters
Total Organic Carbon (TOC)	10.0 mg/L	10.0 mg/L
pH, standard units	6.0 - 8.5	6.5 - 8.5
Total Recoverable Mercury	0.012 µg/L	0.025 µg/L
Total Recoverable Cadmium	9.3 µg/L	9.3 µg/L
Total Recoverable Copper	2.9 µg/L	2.9 µg/L
Total Recoverable Lead	0.03 mg/L	5.6 µg/L
Total Recoverable Zinc	86.0 µg/L	86.0 µg/L
Total Recoverable Chromium (Hex.)	11.0 µg/L	50.0 µg/L
Benzene	1.0 µg/L	1.0 µg/L
Naphthalene	100.0 µg/L	100.0 µg/L

3. FOR FRESH WATERS AND COASTAL WATERS, THE PH OF THE EFFLUENT SHALL NOT BE LOWERED TO LESS THAN 6.0 UNITS FOR FRESH WATERS, OF LESS THAN 6.5 UNITS FOR COASTAL WATERS, OR RAISED ABOVE 8.5 UNITS, UNLESS NATURAL BACKGROUND DATA CONFIRMING A NATURAL BACKGROUND PH OUTSIDE OF THIS RANGE IS SUBMITTED. IF NATURAL BACKGROUND OF THE RECEIVING WATER IS DETERMINED TO BE LESS THAN 6.0 UNITS FOR FRESH WATERS, OR LESS THAN 6.5 UNITS IN COASTAL WATERS, THE PH SHALL NOT VARY BELOW NATURAL BACKGROUND OR VARY MORE THAN ONE (1) UNIT ABOVE NATURAL BACKGROUND FOR FRESH AND COASTAL WATERS. IF NATURAL BACKGROUND OF THE RECEIVING WATER IS DETERMINED TO BE HIGHER THAN 8.5 UNITS, THE PH SHALL NOT VARY ABOVE NATURAL BACKGROUND OR VARY MORE THAN ONE (1) UNIT BELOW NATURAL BACKGROUND OF FRESH AND COASTAL WATERS. THE CONTRACTOR SHALL INCLUDE THE NATURAL BACKGROUND PH OF THE RECEIVING WATERS WITH THE RESULTS OF THE ANALYSES LISTED IN NOTE 2. FOR PURPOSES OF THIS SECTION ONLY, FRESH WATERS ARE THOSE HAVING A CHLORIDE CONCENTRATION OF LESS THAN 1500 MG/L, AND COASTAL WATERS ARE THOSE HAVING A CHLORIDE CONCENTRATION EQUAL TO OR GREATER THAN 1500 MG/L.
4. IN ACCORDANCE WITH RULE 62-302.500 (1) (A-C), F.A.C., THE DISCHARGE SHALL AT ALL TIMES BE FREE FROM FLOATING SOLIDS, VISIBLE FOAM, TURBIDITY, OR VISIBLE OIL IN SUCH AMOUNTS AS TO FORM NUISANCES ON SURFACE WATERS.
5. ALL OF THE GENERAL CONDITIONS LISTED IN RULE 62-621.250, F.A.C., ARE APPLICABLE.

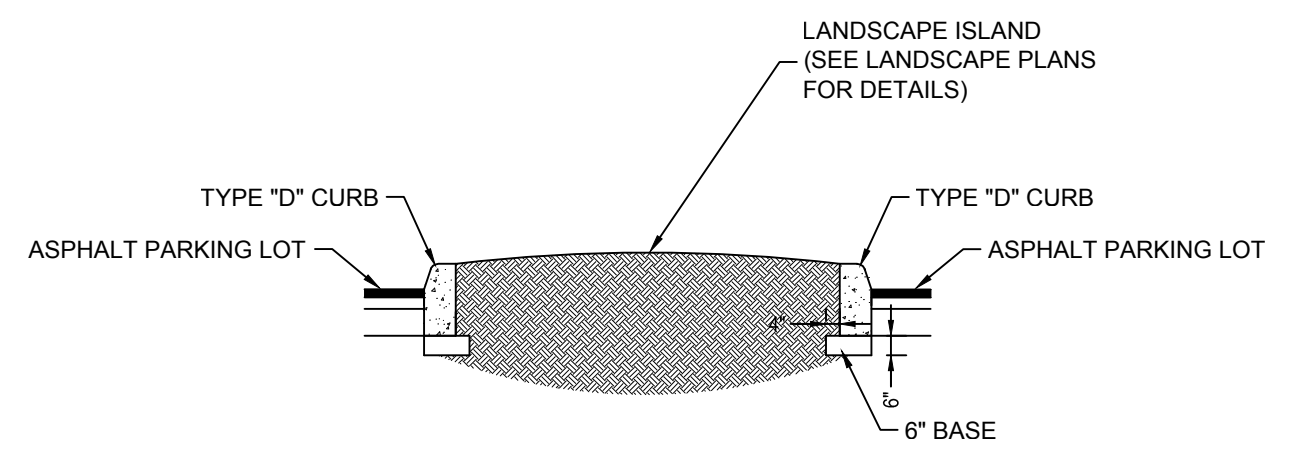

TYPICAL SECTION LANDSCAPE ISLAND
SCALE: N.T.S.

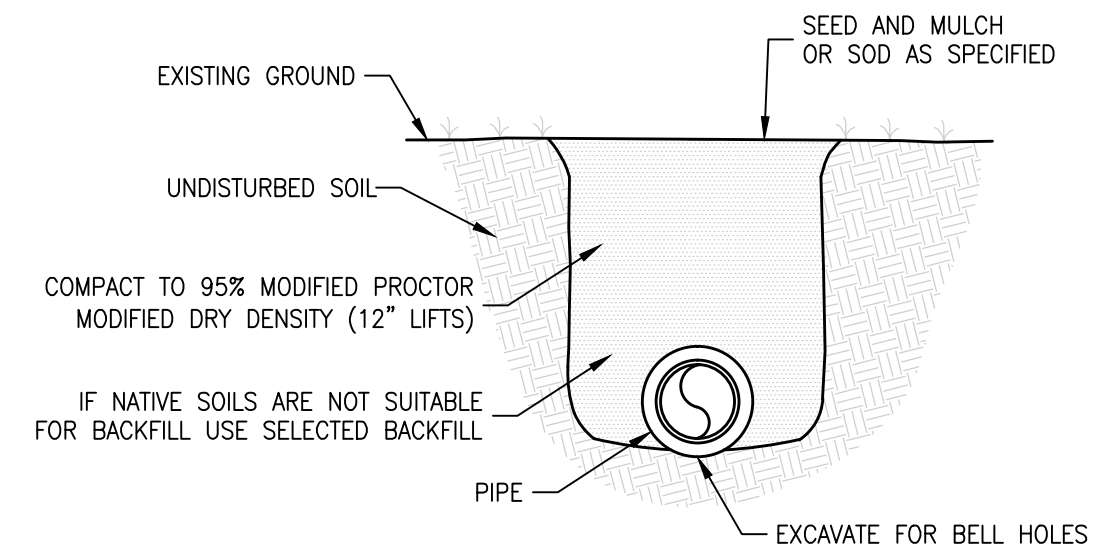

DETAIL STANDARD BEDDING
SCALE: N.T.S.

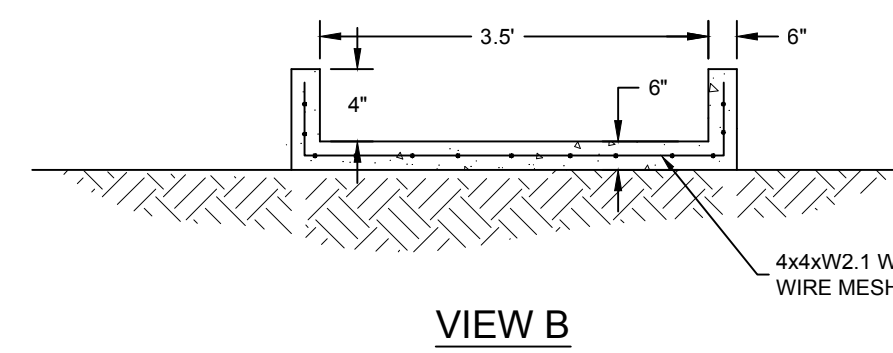

VIEW B

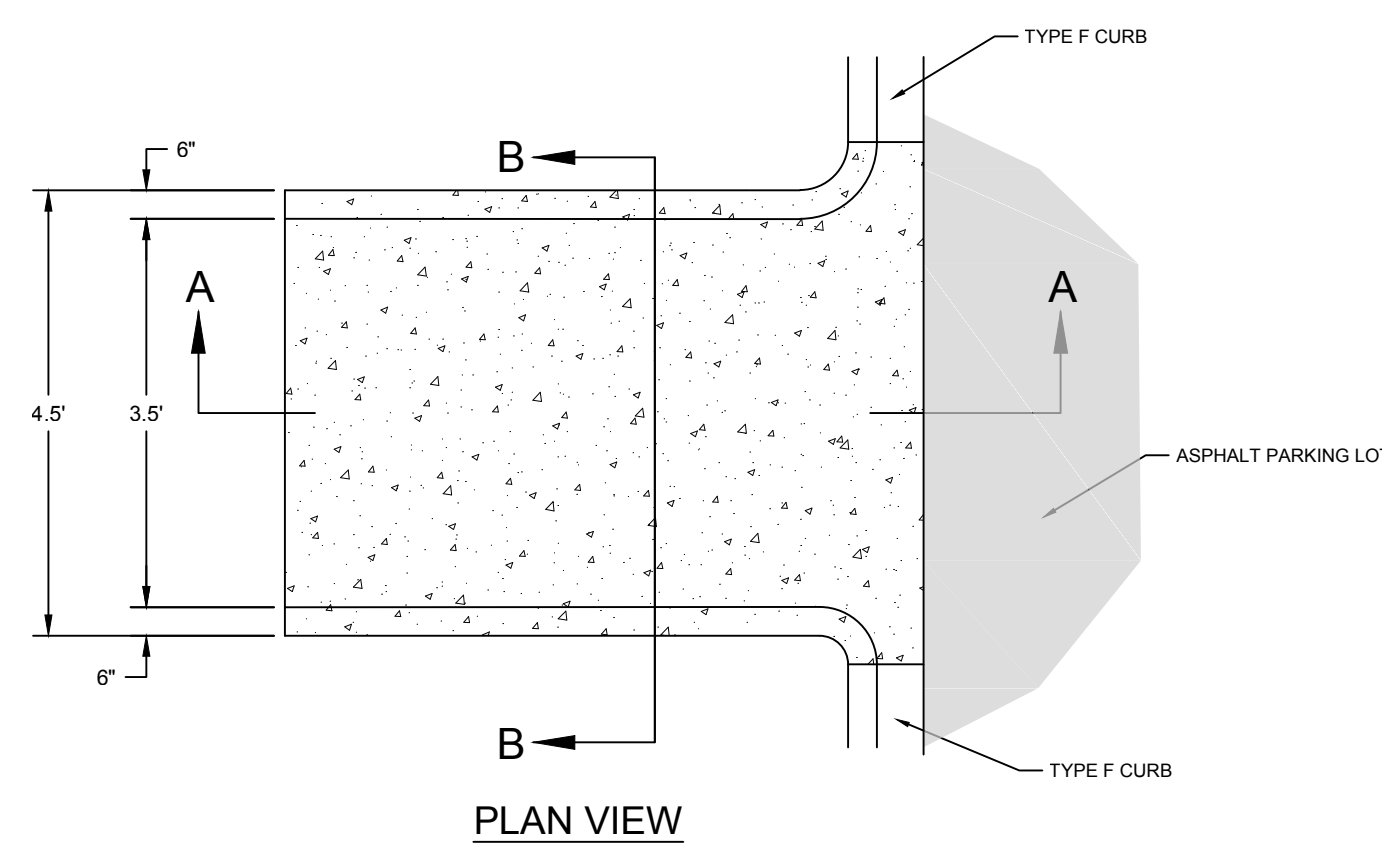

PLAN VIEW

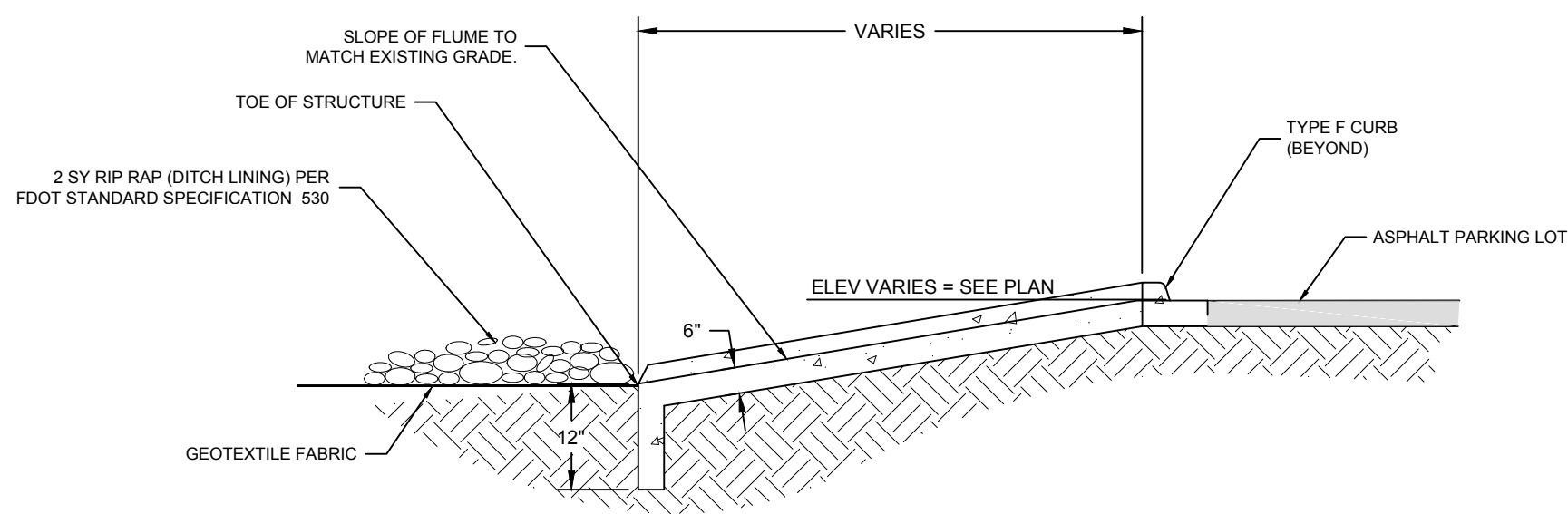

DETAIL CONCRETE FLUME
SCALE: N.T.S.

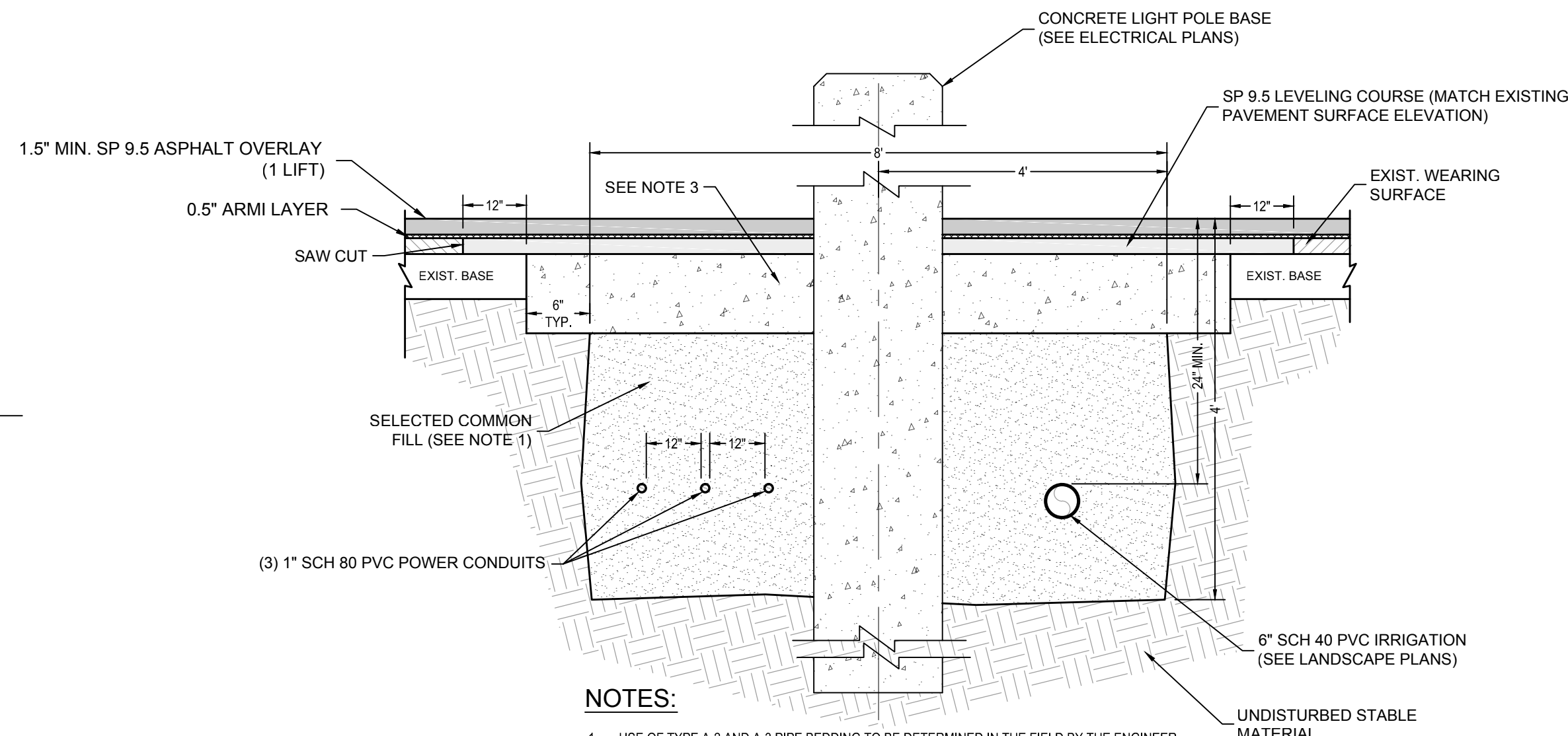

NOTES:

1. USE OF TYPE A-2 AND A-3 PIPE BEDDING TO BE DETERMINED IN THE FIELD BY THE ENGINEER.
2. BASE SHALL BE 8\"/>

DETAIL TYPE 1 TRENCH - REMOVAL AND REPLACEMENT OF ASPHALT PAVING
SCALE: N.T.S.

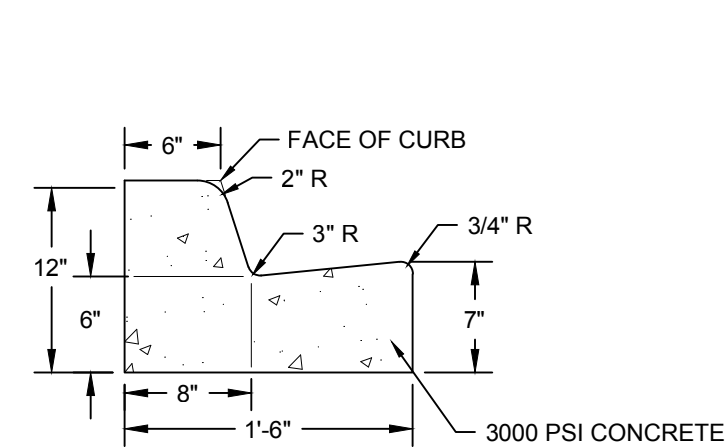

DETAIL MODIFIED TYPE "F" CURB
SCALE: N.T.S.

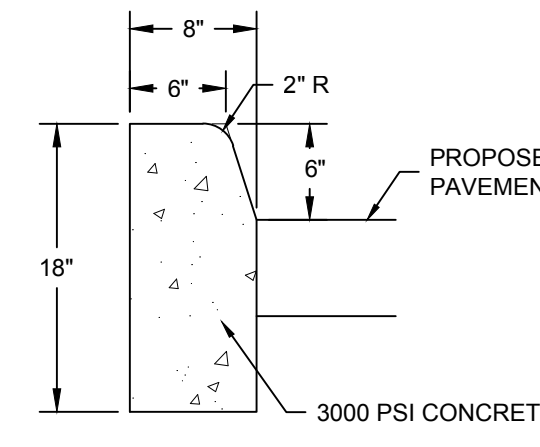

DETAIL TYPE "D" CURB
SCALE: N.T.S.

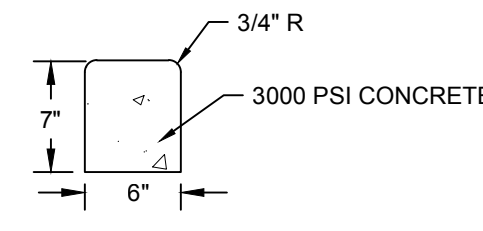

DETAIL CONCRETE RIBBON CURB
SCALE: N.T.S.

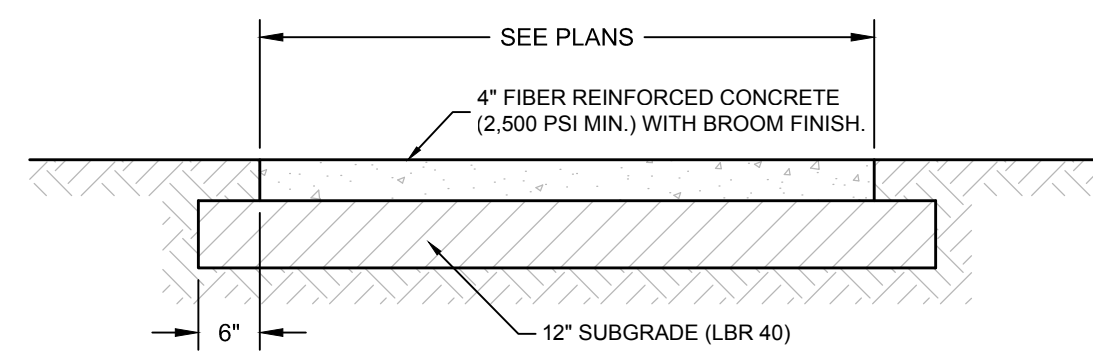

SIDEWALK CROSS SECTION

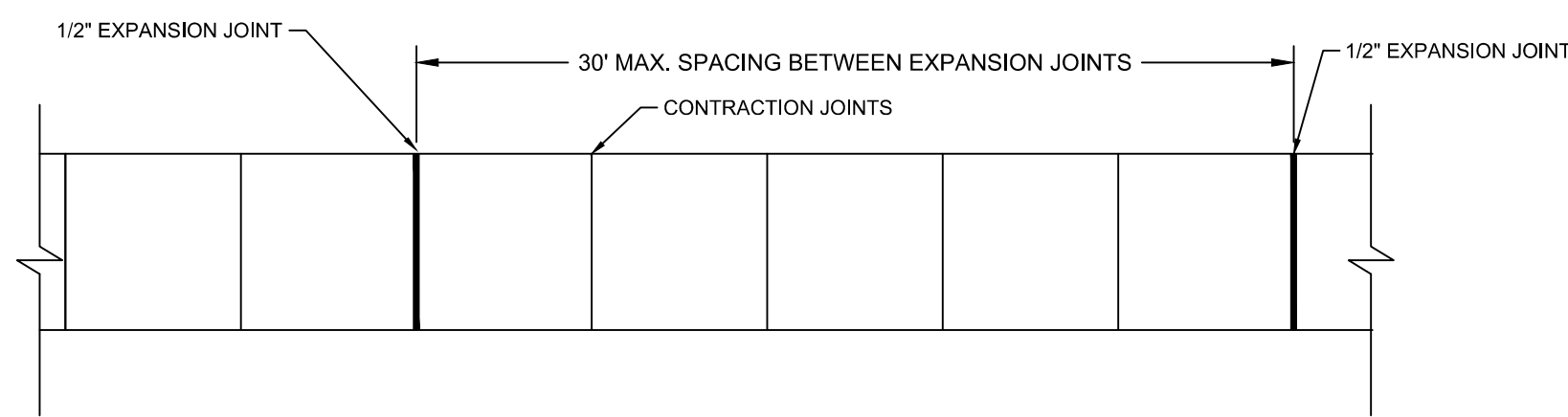

NOTE:

1. ALL SIDEWALKS SHALL BE 4\"/>

DETAIL SIDEWALK
SCALE: N.T.S.

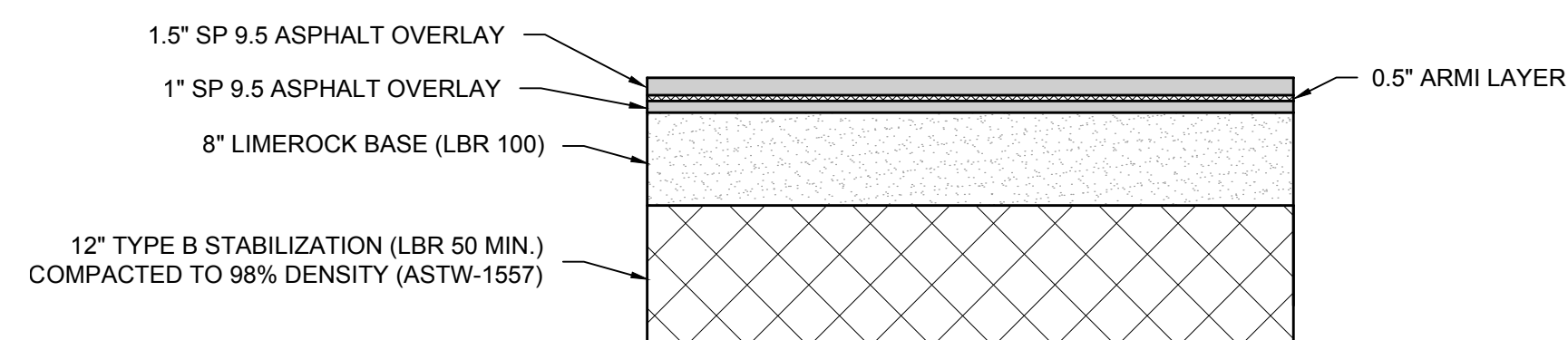

TYPICAL SECTION FULL DEPTH ASPHALT PAVING
SCALE: N.T.S.

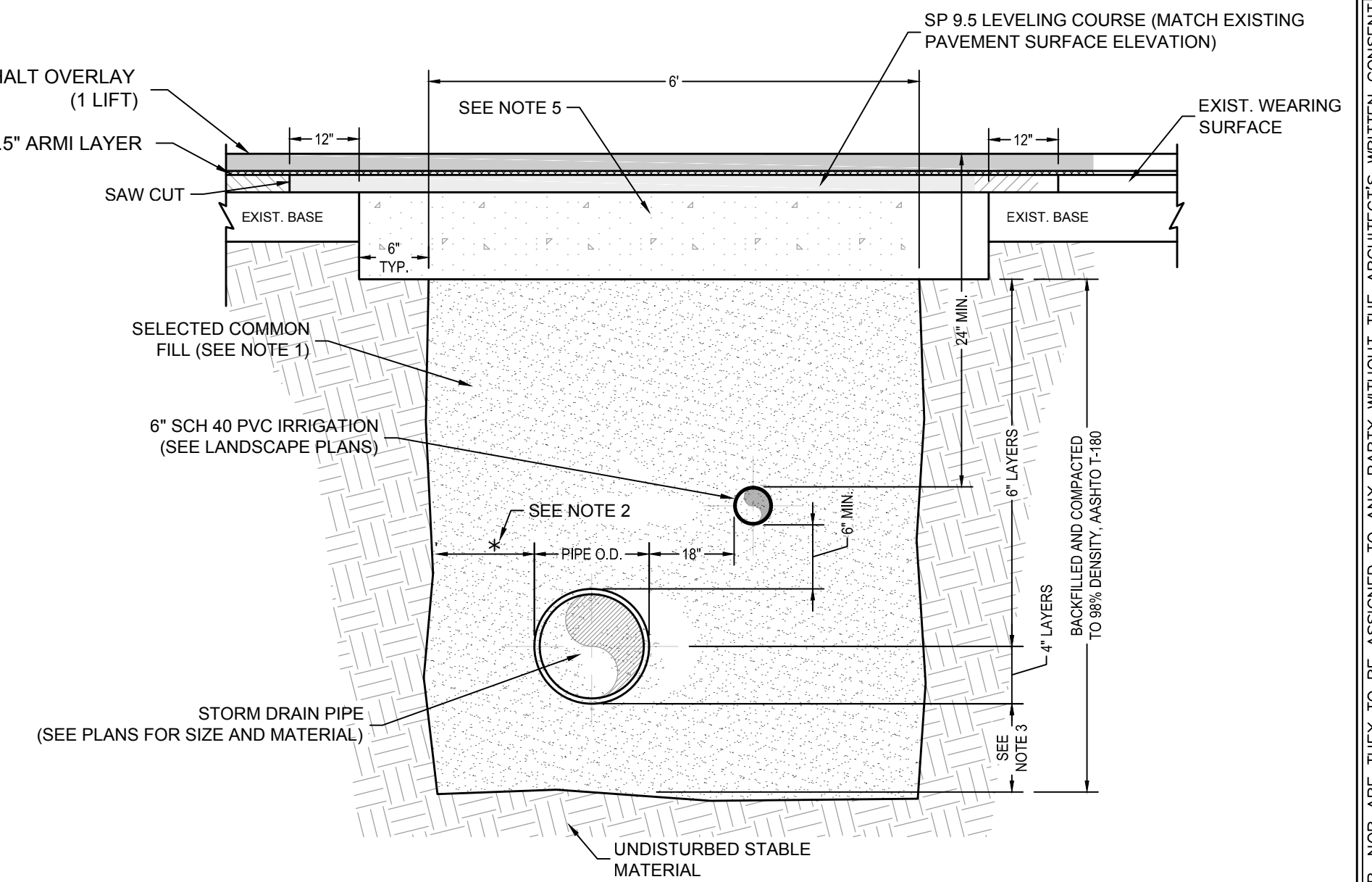

NOTES:

1. USE OF TYPE A-2 AND A-3 PIPE BEDDING TO BE DETERMINED IN THE FIELD BY THE ENGINEER.
2. 10\"/>

DETAIL TYPE 2 TRENCH - REMOVAL AND REPLACEMENT OF ASPHALT PAVING
SCALE: N.T.S.

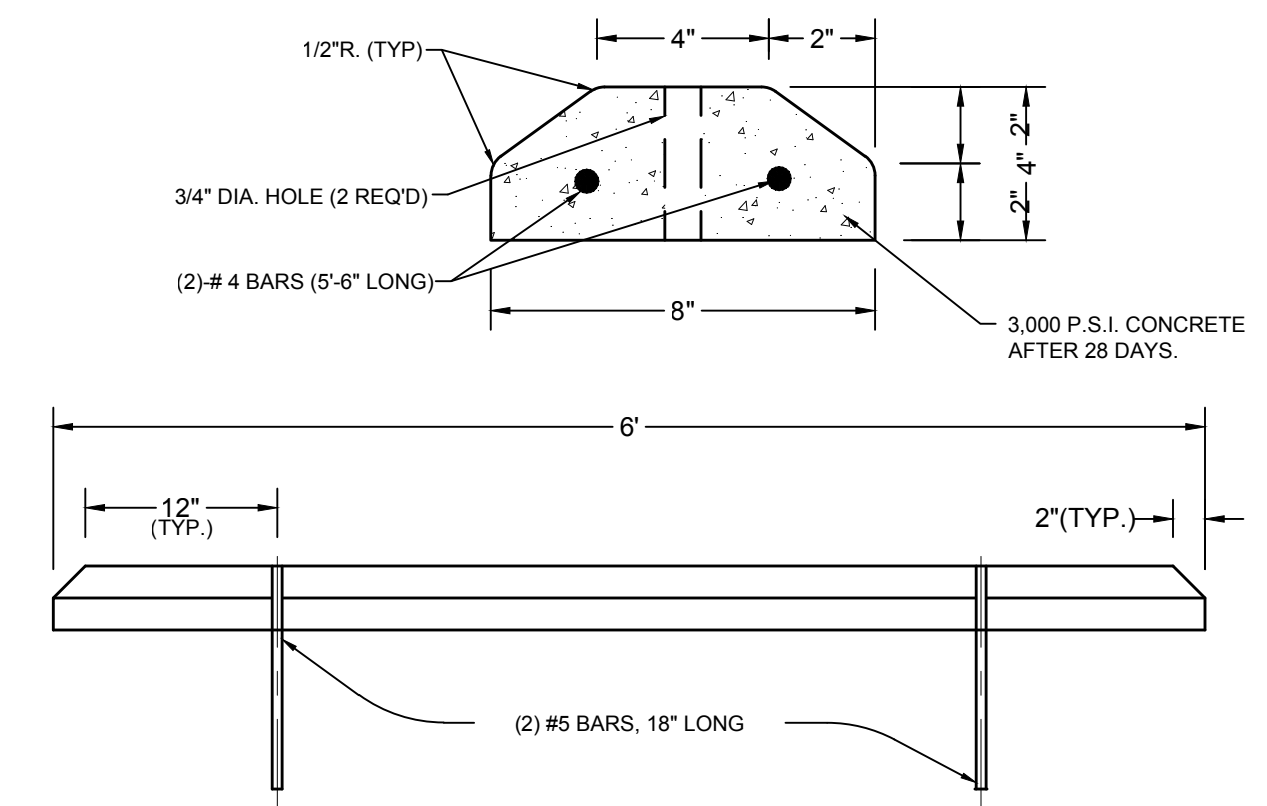

DETAIL TYPICAL PRECAST CONCRETE WHEEL STOP
SCALE: N.T.S.

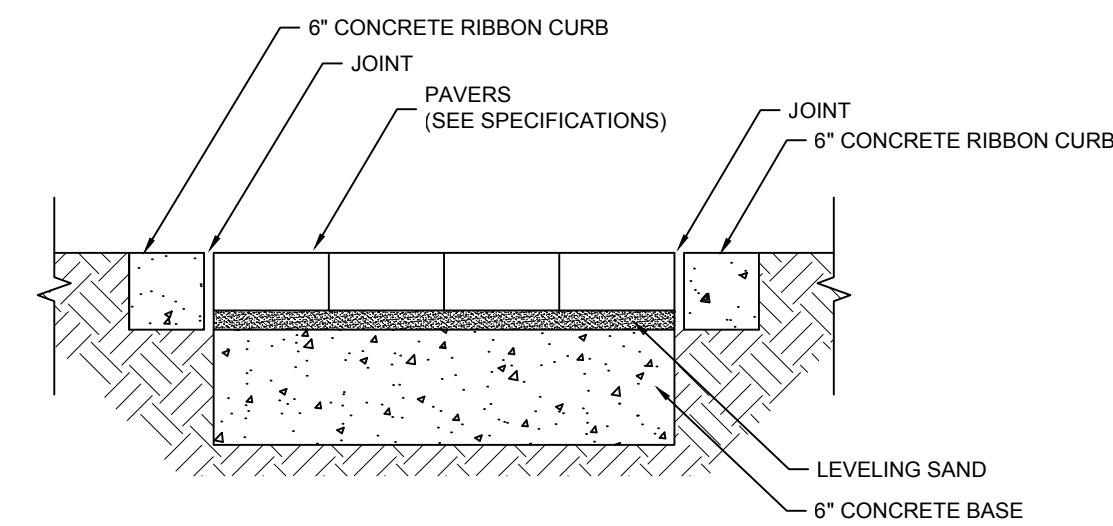

DETAIL VEHICULAR TRAFFIC PAVER
SCALE: N.T.S.

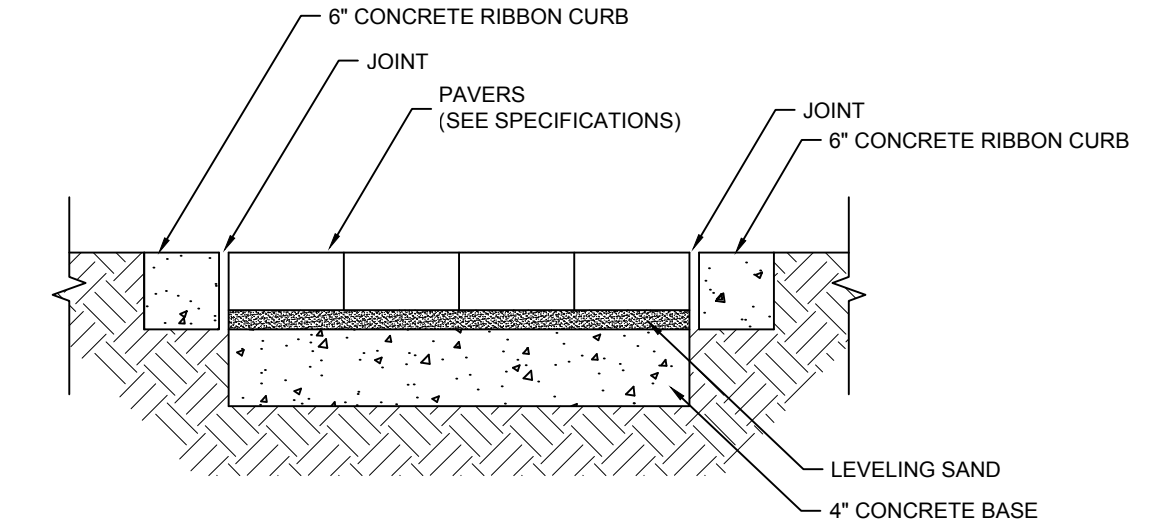

DETAIL PAVER SIDEWALK
SCALE: N.T.S.

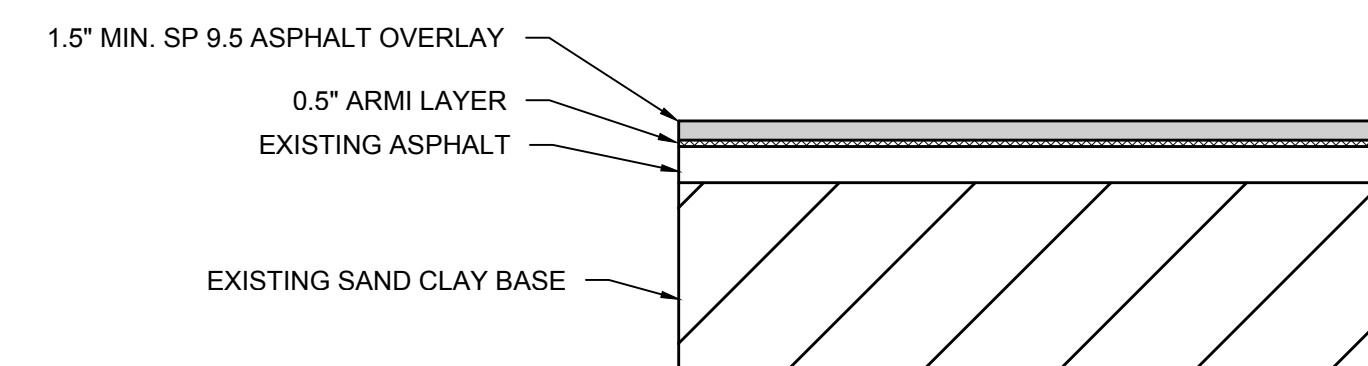

TYPICAL SECTION ASPHALT OVERLAY PAVING
SCALE: N.T.S.

May 6, 2015 (14:46:51 EST)
 K:\Y82.007 GC5C PC PHASE 1\CIVIL3\FOLDER_PRODUCTION\782007_SWPPP.DWG

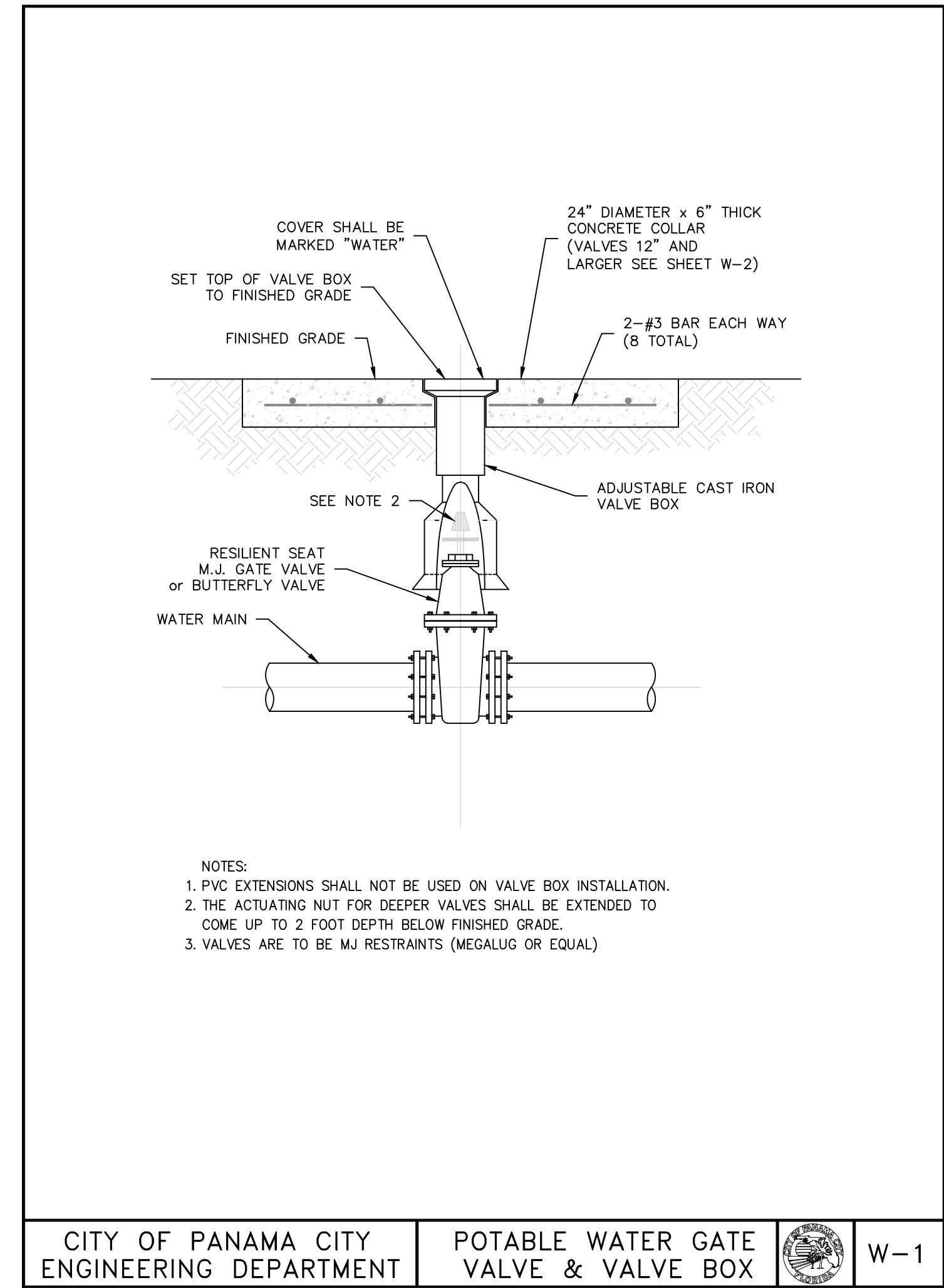

CITY OF PANAMA CITY ENGINEERING DEPARTMENT | POTABLE WATER GATE VALVE & VALVE BOX | W-1

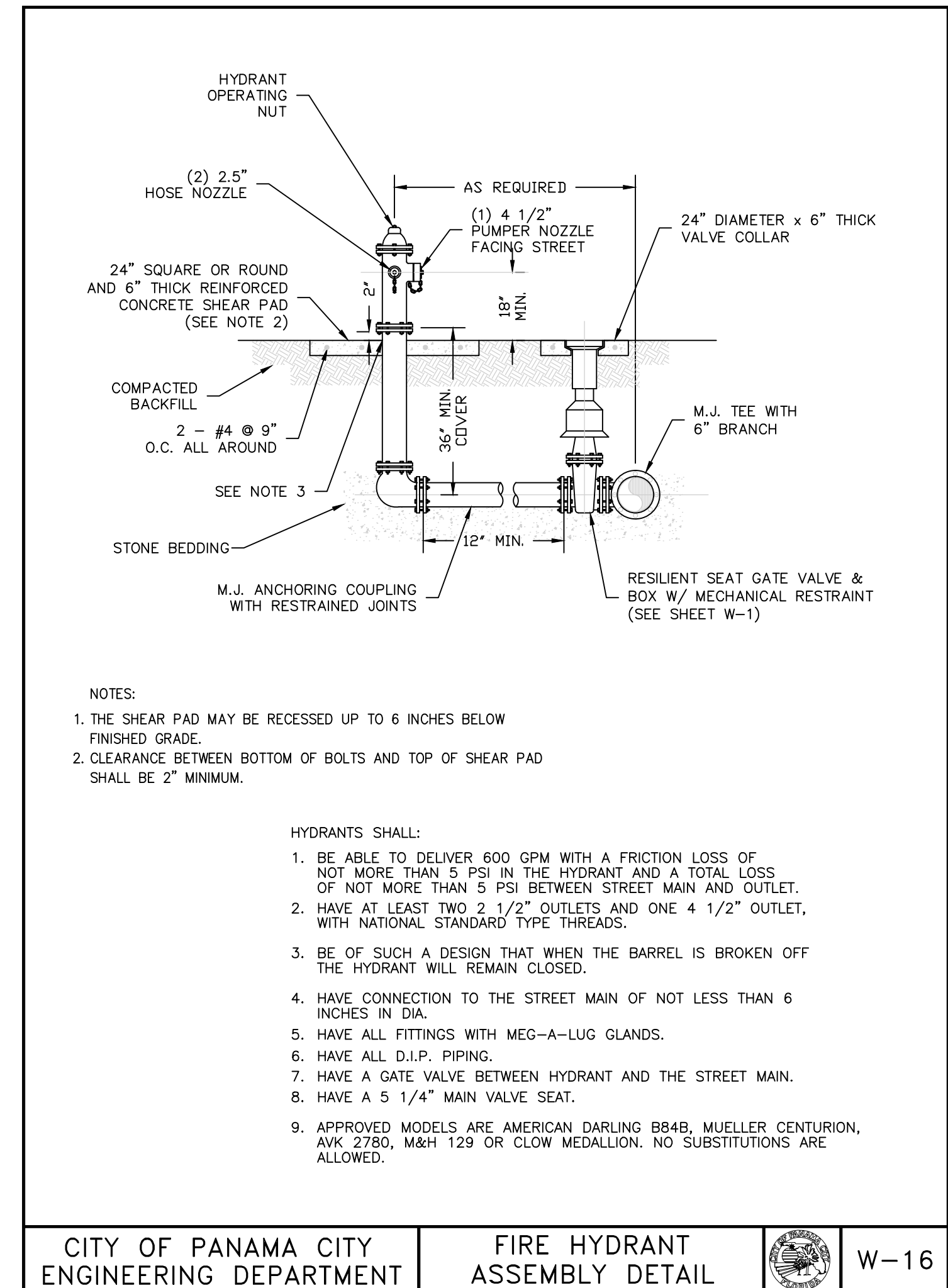

CITY OF PANAMA CITY ENGINEERING DEPARTMENT | FIRE HYDRANT ASSEMBLY DETAIL | W-16



FLORIDA ARCHITECTS
 LICENSE #AA0002730
 648 Florida Avenue
 Panama City, FL 32401
 P 850/257-5400

JONATHAN SKLARSKI
 FL. P.E. 67361

Principal in Charge
 Joseph J. Sorci
 Project Number:
 4166-2
 Date Issued:
 5-7-2015
 Drawn By:
 BWR
 Checked By:
 J.S.
 Revisions:

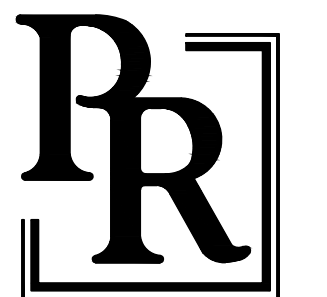

PREBLE-RISH, INC.

GULF COAST STATE COLLEGE
 PHASE 1 CAMPUS
 IMPROVEMENTS

MISCELLANEOUS DETAILS

BID DOCUMENTS
 Sheet Number
C20

Copyright © 2015 BY FLORIDA ARCHITECTS, INC. ARCHITECT EXPRESSLY RESERVES HIS EXCLUSIVE COMMON LAW COPYRIGHT AND PROPERTY RIGHTS TO THESE DRAWINGS WHICH MAY NOT BE REPRODUCED, CHANGED OR COPIED IN ANY FORM OR MANNER, NOR ARE THEY TO BE ASSIGNED TO ANY PARTY WITHOUT THE ARCHITECT'S WRITTEN CONSENT.

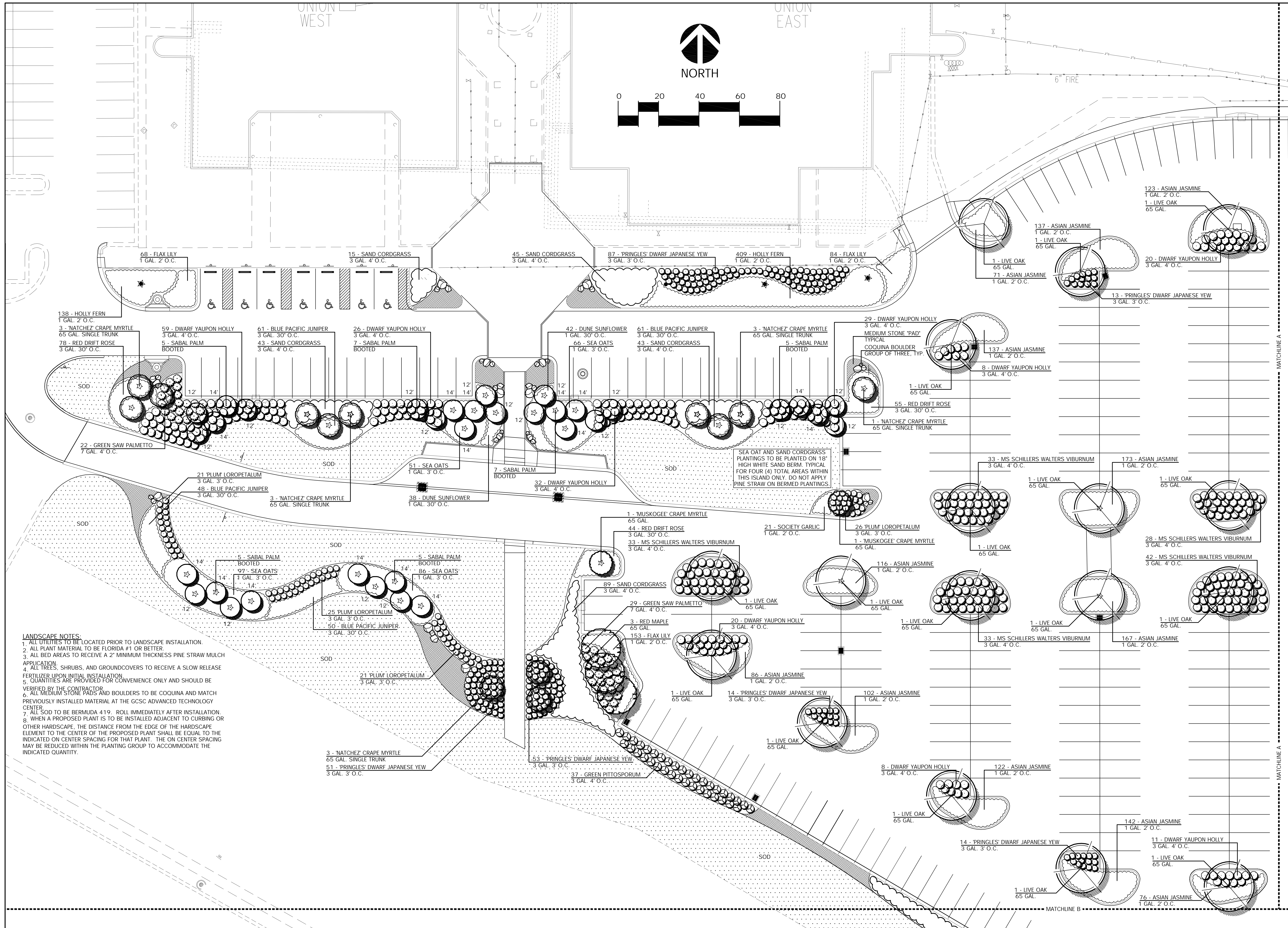

LANDSCAPE NOTES:
 1. ALL UTILITIES TO BE LOCATED PRIOR TO LANDSCAPE INSTALLATION.
 2. ALL PLANT MATERIAL TO BE FLORIDA #1 OR BETTER.
 3. ALL BED AREAS TO RECEIVE A 2" MINIMUM THICKNESS PINE STRAW MULCH APPLICATION.
 4. ALL TREES, SHRUBS, AND GROUNDCOVERS TO RECEIVE A SLOW RELEASE FERTILIZER UPON INITIAL INSTALLATION.
 5. QUANTITIES ARE PROVIDED FOR CONVENIENCE ONLY AND SHOULD BE VERIFIED BY THE CONTRACTOR.
 6. ALL MEDIUM STONE PADS AND BOULDERS TO BE COQUINA AND MATCH PREVIOUSLY INSTALLED MATERIAL AT THE GCSC ADVANCED TECHNOLOGY CENTER.
 7. ALL SOD TO BE BERMUDA 419. ROLL IMMEDIATELY AFTER INSTALLATION.
 8. WHEN A PROPOSED PLANT IS TO BE INSTALLED ADJACENT TO CURBING OR OTHER HARDSCAPE, THE DISTANCE FROM THE EDGE OF THE HARDSCAPE ELEMENT TO THE CENTER OF THE PROPOSED PLANT SHALL BE EQUAL TO THE INDICATED ON CENTER SPACING FOR THAT PLANT. THE ON CENTER SPACING MAY BE REDUCED WITHIN THE PLANTING GROUP TO ACCOMMODATE THE INDICATED QUANTITY.

Copyright © 2015 by Florida Architects, Inc. All rights reserved. This drawing is the property of Florida Architects, Inc. and shall not be reproduced, changed or copied in any form or manner, used here, or be assigned to any party without the architect's written consent.

45 - GREEN PITTIOSPORUM

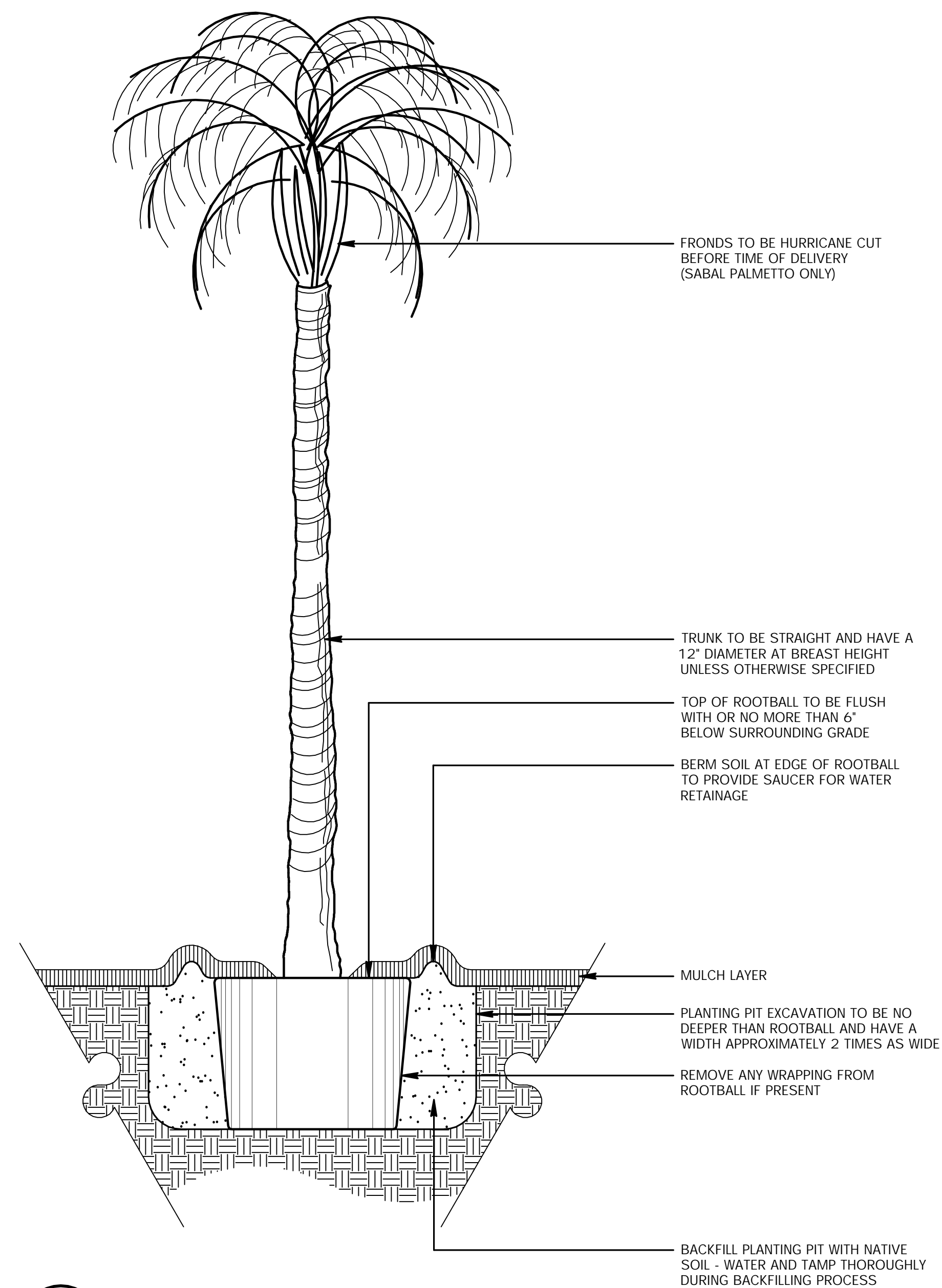
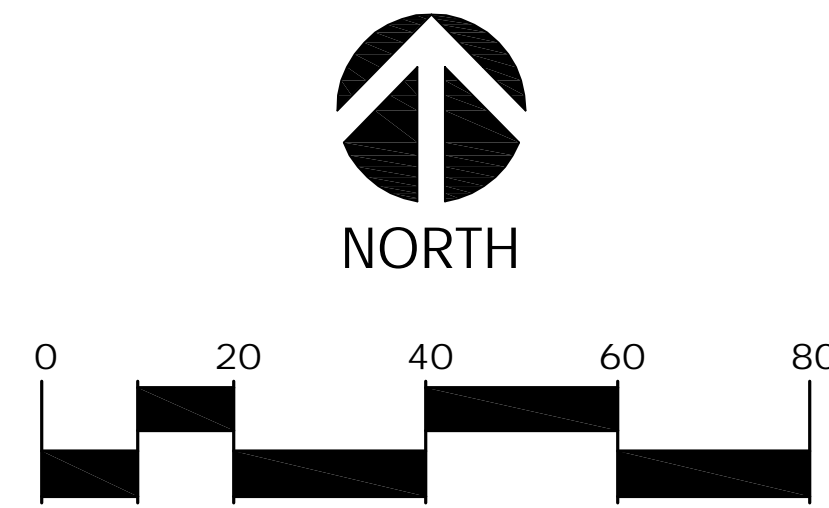
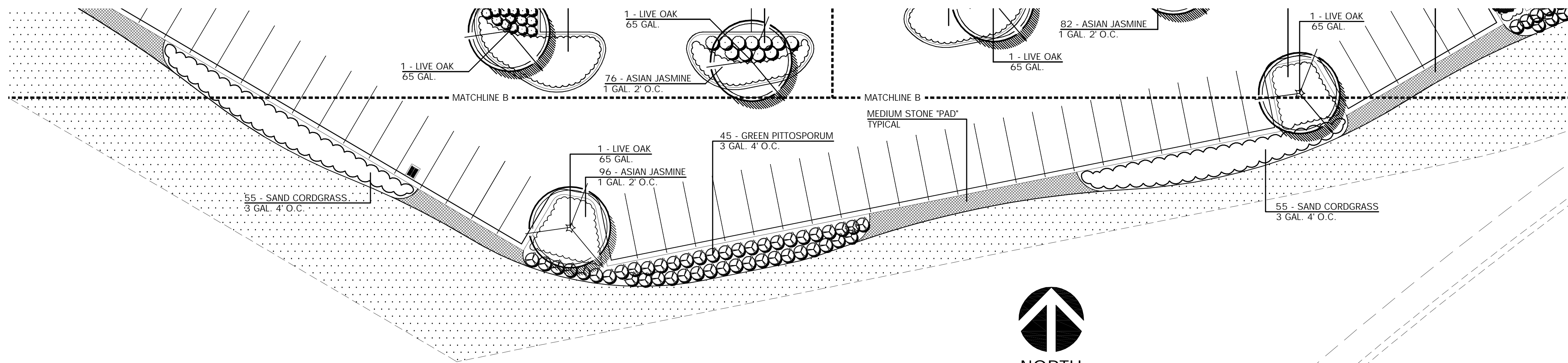

1 PALM PLANTING DETAIL
L3.0 NOT TO SCALE

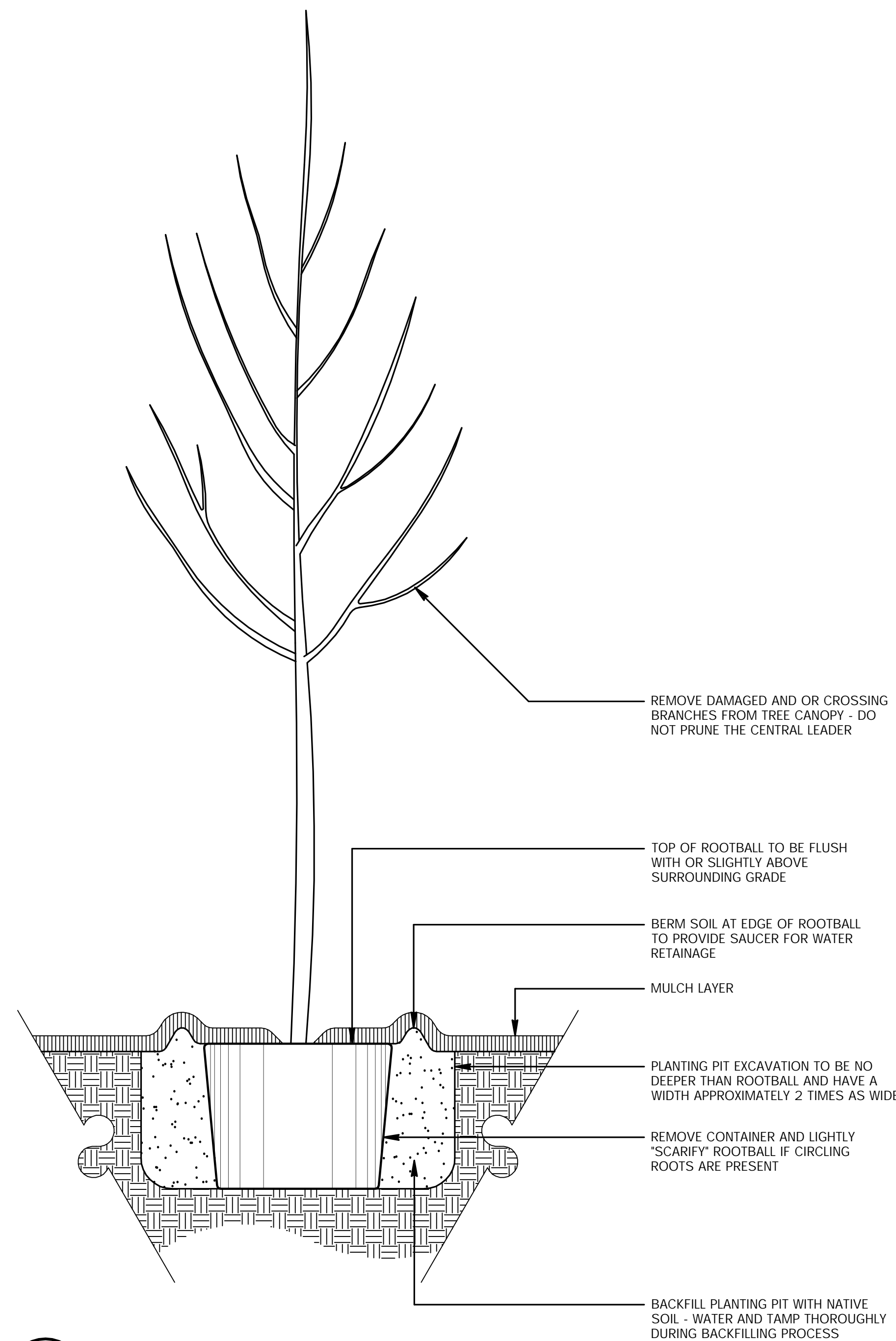

2 TREE PLANTING DETAIL
L3.0 NOT TO SCALE

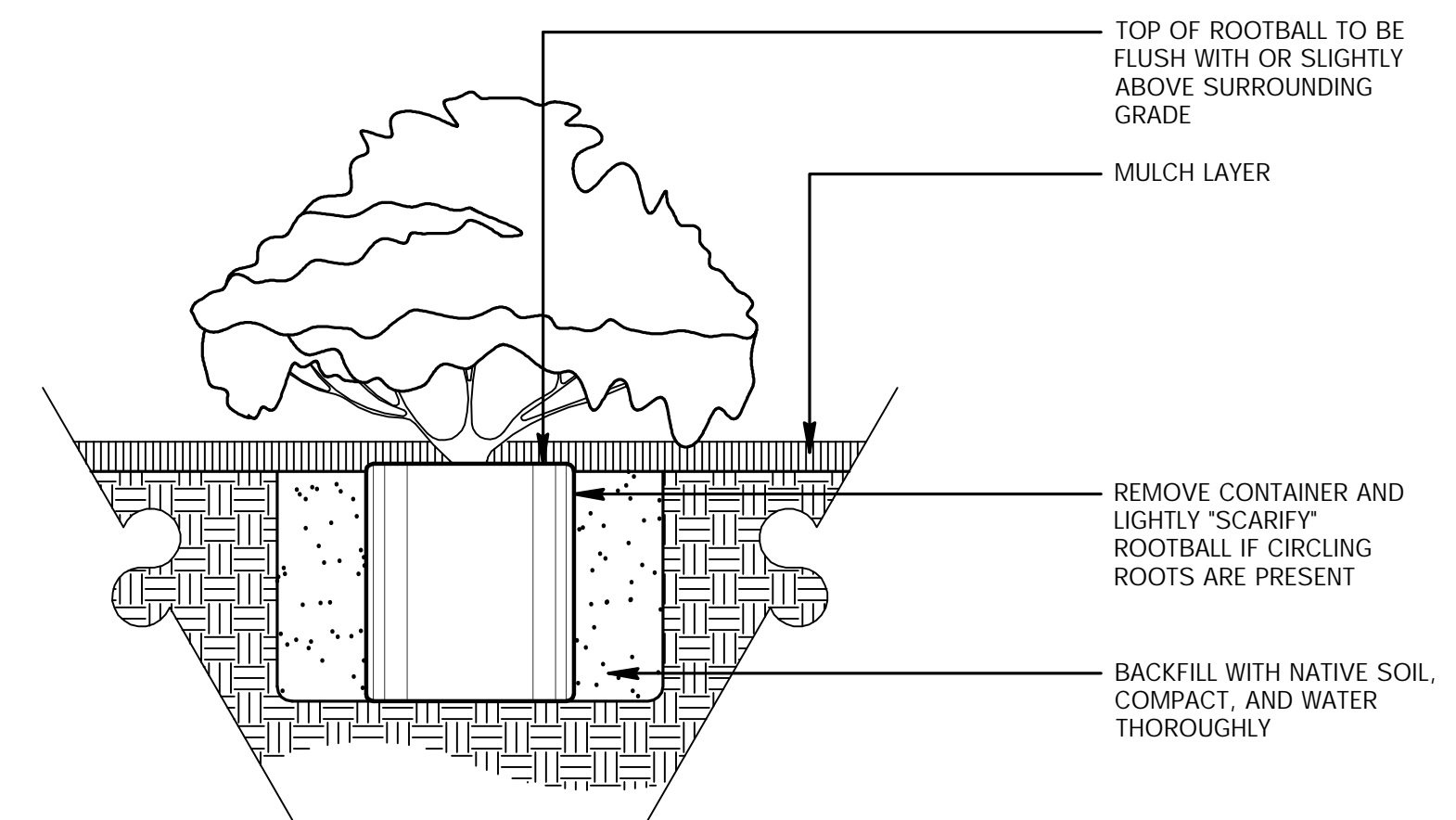

3 CONTAINER SHRUB PLANTING
L3.0 NOT TO SCALE

Copyright © 2015 by Florida Architects, Inc. All rights reserved. No part of this drawing may be reproduced, stored in a retrieval system, or transmitted in any form or by any means, electronic, mechanical, photocopying, recording, or by any information storage and retrieval system, without the prior written consent of Florida Architects, Inc.



FLORIDA ARCHITECTS
 LICENSE #AA0002730
 648 Florida Avenue
 Panama City, FL 32401
 P 850/257-5400

Principal In Charge
Joseph J. Sorci
 Project Number:
4166-2
 Date Issued:
5-7-2015
 Drawn By:

Checked By:
S.D.
 Revisions:



**GULF COAST STATE COLLEGE
 PHASE 1 CAMPUS
 IMPROVEMENTS**

**IRRIGATION
 PLAN**

BID DOCUMENTS
 Sheet Number
L4.0

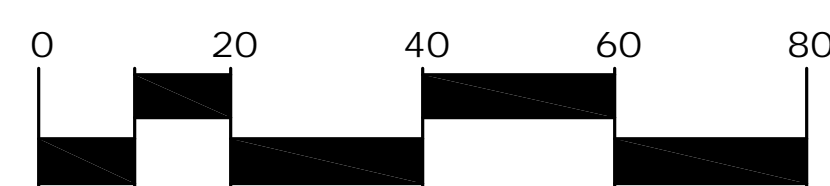
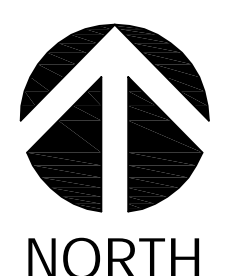
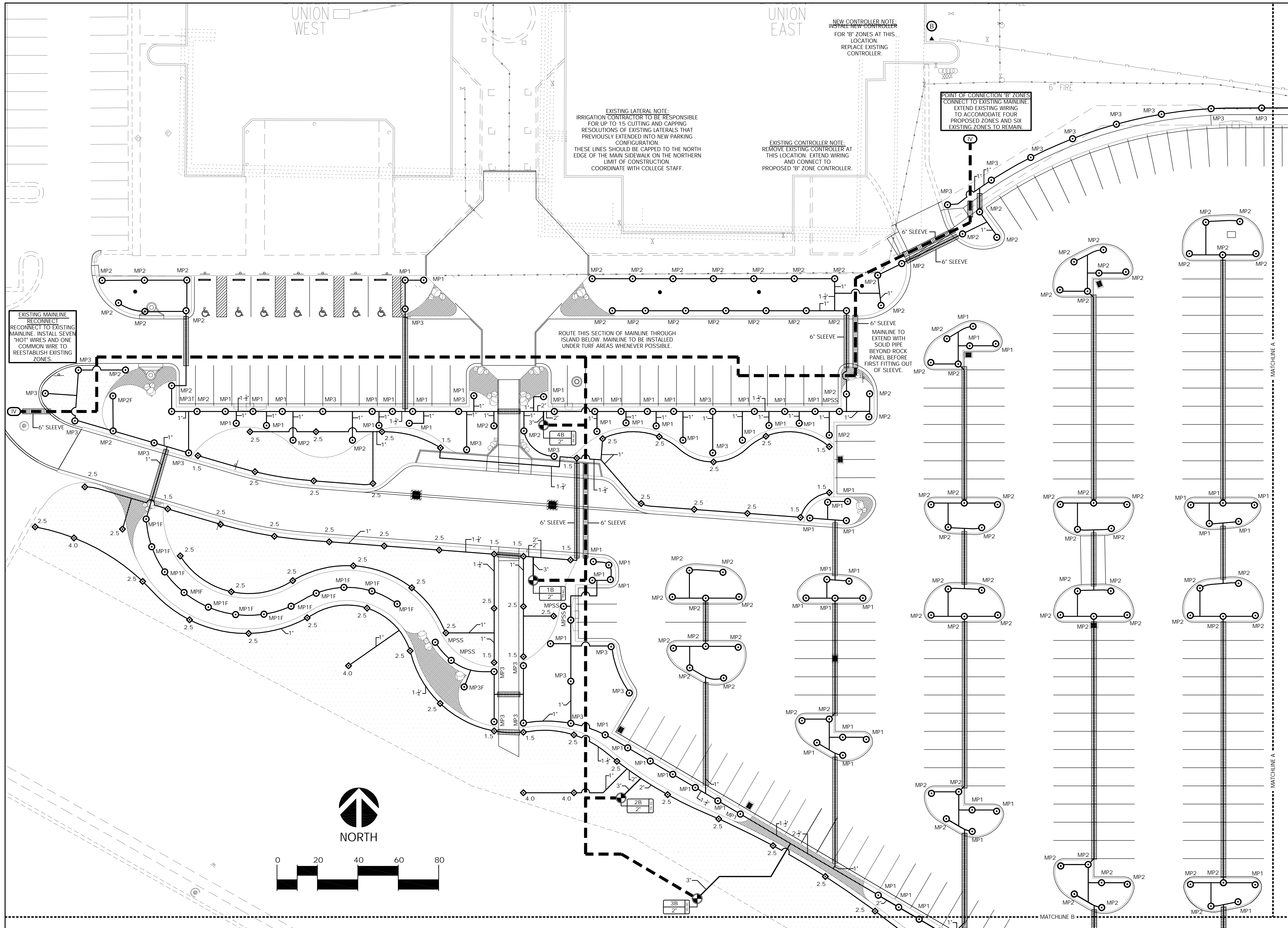

Copyright © 2015 by Florida Architects, Inc. All rights reserved. This drawing is the property of Florida Architects, Inc. and is not to be reproduced, changed or copied in any form or manner, used here, or to be assigned to any party without the architect's written consent.

**GULF COAST STATE COLLEGE
 PHASE 1 CAMPUS
 IMPROVEMENTS**

**IRRIGATION
 PLAN**

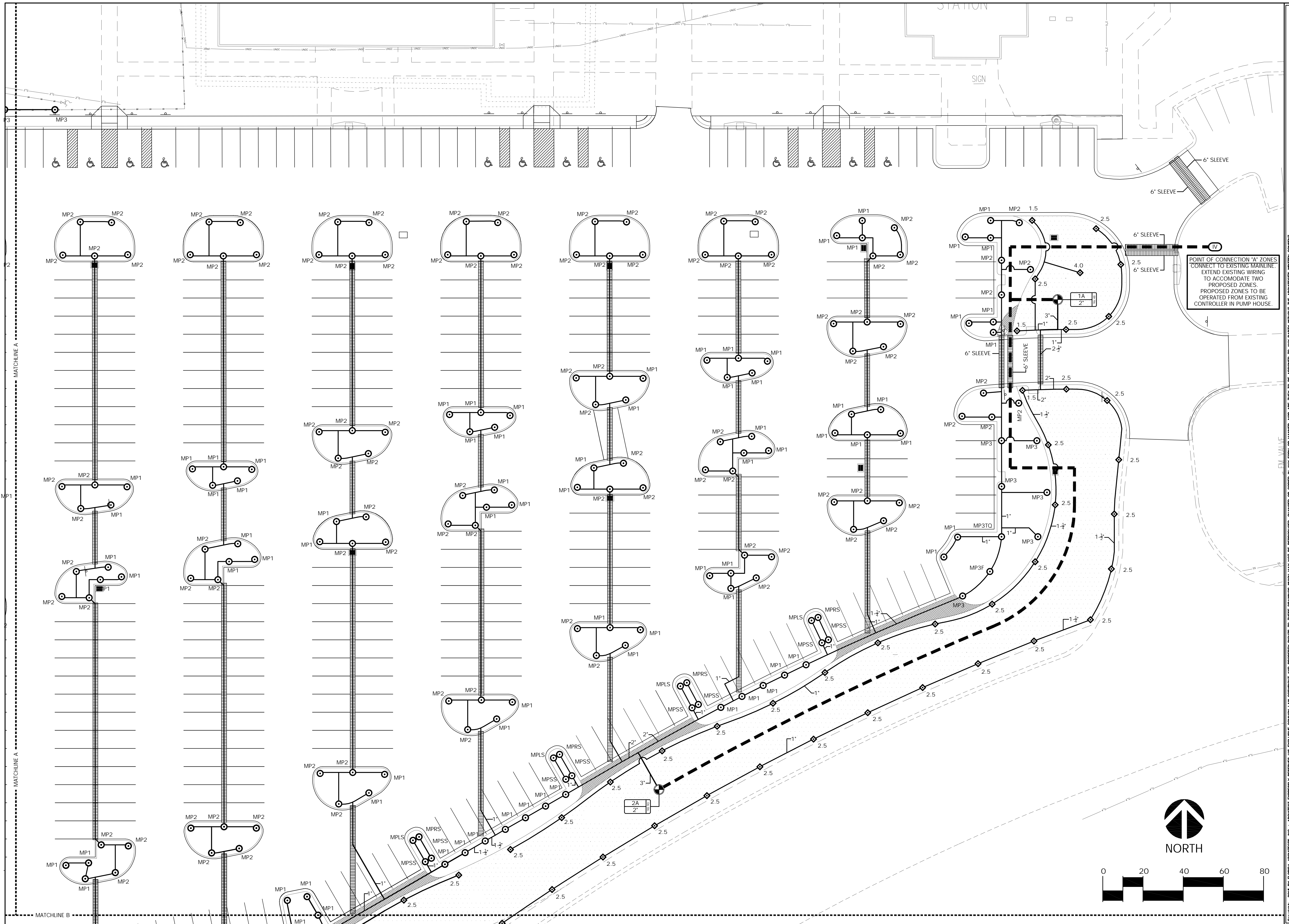

Copyright © 2015 by Florida Architects, Inc. All rights reserved. No part of this drawing may be reproduced, stored in a retrieval system, or transmitted in any form or by any means, electronic, mechanical, photocopying, recording, or by any information storage and retrieval system, without the prior written consent of Florida Architects, Inc.

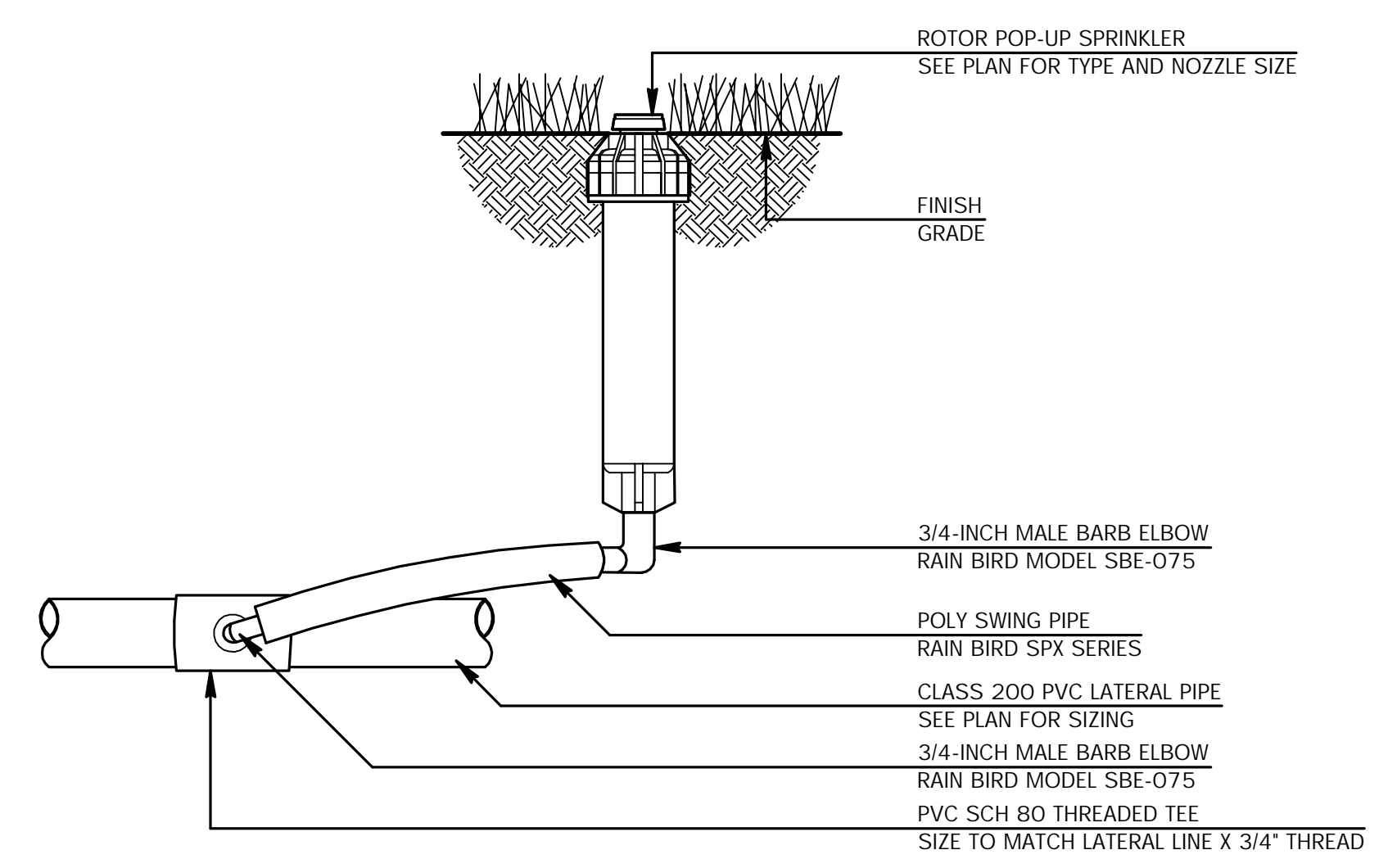
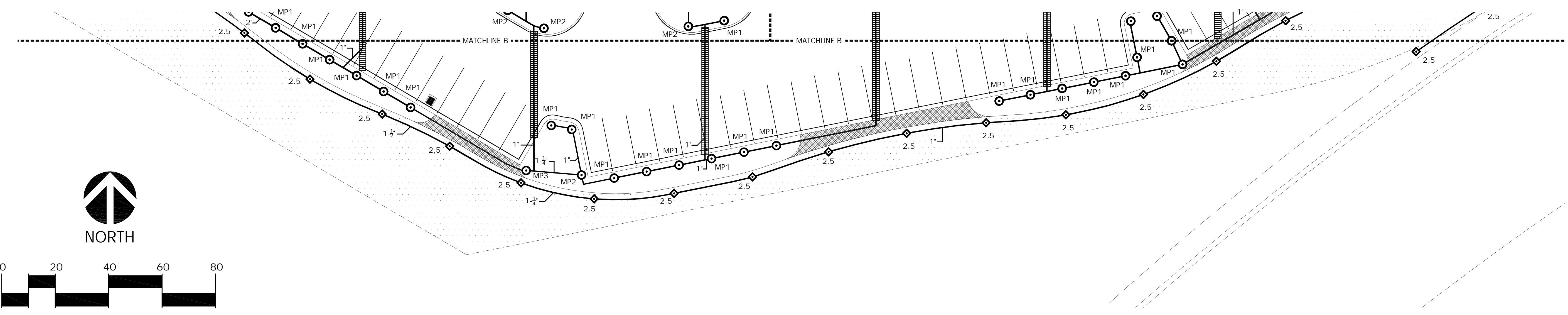

1 POP-UP ROTOR INSTALLATION
 L6.0 NOT TO SCALE

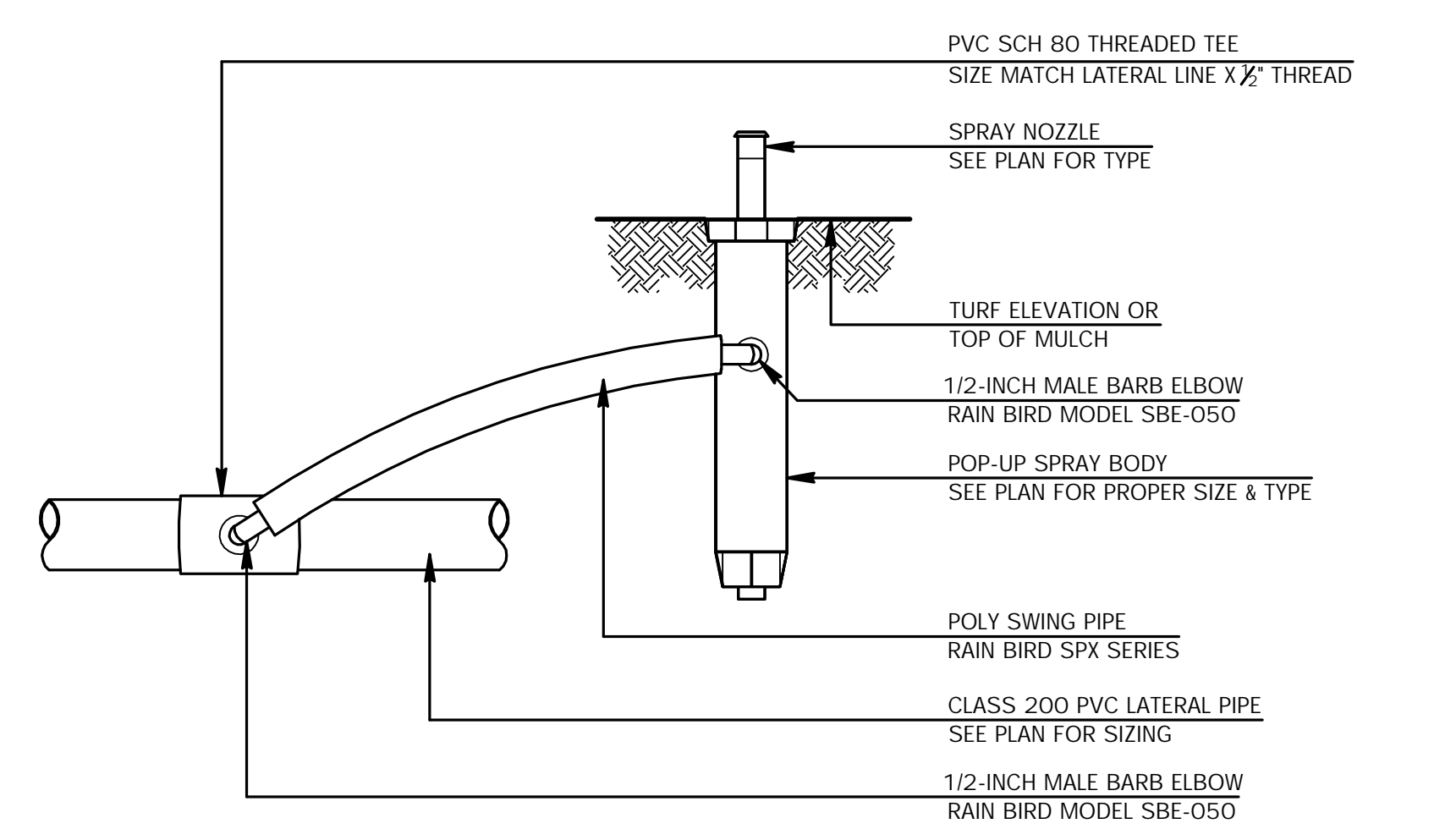

2 SPRAYHEAD INSTALLATION
 L6.0 NOT TO SCALE

GENERAL IRRIGATION NOTES: BEFORE COMMENCEMENT OF CONSTRUCTION, APPLY NECESSARY PROTECTIVE MEASURES TO REDUCE POSSIBILITY OF DAMAGE TO EXISTING UTILITIES DURING CONSTRUCTION.

- ALL CONTROL WIRE TO BE 14 GAUGE. INSTALL ONE (1) RED WIRE TO EACH CONTROL VALVE, ONE (1) COMMON WHITE TO LOOP CONTINUOUSLY THROUGHOUT THE WIRE PATH, AND ONE (1) EXTRA BLUE WIRE TO RUN PARALLEL WITH COMMON.
- ALL LATERAL LINES TO MAINTAIN A 8" MINIMUM DEPTH. ALL MAINLINE TO MAINTAIN A MINIMUM 12" DEPTH.
- ALL SPRAYS AND ROTORS TO BE MOUNTED FLUSH WITH FINAL GRADE.
- ALL WATERING ARCS TO BE ADJUSTED TO PREVENT OVERSPRAY ONTO ADJACENT BUILDINGS OR HARDSCAPE.
- DO NOT VERTICALLY STACK MULTIPLE PIPES IN A SINGLE TRENCH. ALL PIPING IN SHARED TRENCHES TO MAINTAIN A 3" MINIMUM SPACING BETWEEN PIPES.

SYSTEM DESIGN NOTES:

'A' ZONES
 WATER SOURCE: EXISTING PUMP
 DESIGN VOLUME: 100 GPM
 DESIGN PRESSURE: 60 PSI

'B' ZONES
 WATER SOURCE: EXISTING PUMP
 DESIGN VOLUME: 100 GPM
 DESIGN PRESSURE: 60 PSI

PIPING LEGEND

- 3" - CLASS 200 MAINLINE
- CLASS 200 LATERAL (SIZE AS NOTED)
- 4" SCH. 40 SLEEVE (UNLESS OTHERWISE NOTED)
- CONTROL VALVE IDENTIFICATION TAG

IRRIGATION SCHEDULE

QUANTITY	SYMBOL	SIZE / DESC.	DESCRIPTION	MANUFACTURER
167	⊙	MP1	MP-1000-90 ON 1812 BODY	HUNTER
12	⊙	MP1F	MP-1000-360 ON 1812 BODY	HUNTER
202	⊙	MP2	MP-2000-90 ON 1812 BODY	HUNTER
1	⊙	MP2F	MP-2000-360 ON 1812 BODY	HUNTER
37	⊙	MP3	MP-3000-90 ON 1812 BODY	HUNTER
2	⊙	MP3T	MP-3000-210 ON 1812 BODY	HUNTER
2	⊙	MP3F	MP-3000-360 ON 1812 BODY	HUNTER
4	⊙	MPLS	MPLCS515 ON 1812 BODY	HUNTER
4	⊙	MPRS	MPRCS515 ON 1812 BODY	HUNTER
13	⊙	MPSS	MPS530 ON 1812 BODY	HUNTER
17	◇	1.5	5004-PC W/ 1.5 NOZZLE	RAINBIRD
94	◇	2.5	5004-PC W/ 2.5 NOZZLE	RAINBIRD
5	◇	4.0	5004-PC W/4.0 NOZZLE	RAINBIRD
6	⊕	2"	2" CONTROL VALVE 200-PGA	RAINBIRD
1	⊕	-	18 STATION CONTROLLER IC-1800-M	RAINBIRD
1	▲	-	RAIN SENSOR MINI-CLIK	HUNTER
3	Ⓢ	-	3" BRASS GATE VALVE	SPEARS

Copyright © 2015 by FLORIDA ARCHITECTS, INC. ALL ARCHITECT EXPRESSLY RESERVES HIS EXCLUSIVE COMMON LAW COPYRIGHT AND PROPERTY RIGHTS TO THESE DRAWINGS WHICH MAY NOT BE REPRODUCED, CHANGED OR COPIED IN ANY FORM OR MANNER, NOR ARE THEY TO BE ASSIGNED TO ANY PARTY WITHOUT THE ARCHITECT'S WRITTEN CONSENT.

ELECTRICAL LEGEND

LIGHTING

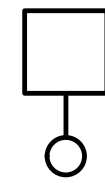

NEW SINGLE HEAD LED FIXTURE WITH 30' POLE AND 3' SQUARE (DIAMOND) BASE

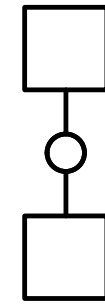

NEW DOUBLE HEAD LED FIXTURE WITH 30' POLE AND 3' SQUARE (DIAMOND) BASE

BRANCH CIRCUITING

--- RUN CONCEALED UNDER FLOOR OR IN GRADE

— RUN CONCEALED ABOVE CEILING

← HOMERUN TO PANEL. LETTERS AND NUMERALS INDICATED PANEL AND CIRCUIT NUMBER.

LA-1

PANELS AND POWER

■ ELECTRICAL PANELBOARD

□ NON-FUSIBLE DISCONNECT SWITCH; XX/YY/ZZ WHERE X INDICATES AMPERAGE, Y INDICATES # OF POLES, AND Z INDICATES NEMA RATING

MISCELLANEOUS

A.F.F.	ABOVE FINISHED FLOOR	C/L	CENTERLINE
ATS	AUTOMATIC TRANSFER SWITCH	C	CONDUIT
WP	WEATHERPROOF	GND	GROUND
GFCI	GROUND FAULT CIRCUIT INTERRUPTER	MT	MOUNT
GCSC	GULF COAST STATE COLLEGE		

ELECTRICAL GENERAL NOTES

- ENTIRE ELECTRICAL INSTALLATION SHALL BE IN ACCORDANCE WITH THE LATEST ACCEPTED EDITION OF THE NATIONAL ELECTRICAL CODE AND ALL LOCAL CODES.
- ALL ELECTRICAL WORK AND MATERIALS USED IN THIS PROJECT SHALL BE NEW, UNDERWRITERS' LABORATORIES (UL) LISTED AND LABELED, AND SHALL BE FURNISHED AND INSTALLED BY THE CONTRACTOR UNLESS NOTED OTHERWISE.
- WHERE CONFLICTS OCCUR ON ELECTRICAL DRAWINGS BETWEEN DRAWINGS, SPECIFICATIONS AND CODES, THE MOST STRINGENT REQUIREMENT THAT APPLIES SHALL BE ADHERED TO.
- NEW POLE SHALL BE FURNISHED WITH A SURGE PROTECTION DEVICE INSTALLED IN THE HANDHOLE NEAR THE BASE OF THE POLE.
- ALL WIRING SHALL BE COPPER AND INSTALLED IN CONDUIT.
- THE ELECTRICAL CONTRACTOR SHALL COORDINATE ALL WORK WITH THE CIVIL AND LANDSCAPE DRAWINGS. UTILIZE COMMON TRENCHES FOR INSTALLATION OF CONDUITS WHERE POSSIBLE. PRIOR TO INSTALLATION OF CONDUIT, THE ELECTRICAL CONTRACTOR WILL BE REQUIRED TO PLAN ALL CONDUIT ROUTING WITH THE OTHER CONTRACTORS PERFORMING SITE WORK. SUBMIT A RECORD OF THIS COORDINATION TO THE ARCHITECT PRIOR TO STARTING SITE WORK. IF ONE CONTRACTOR IS PERFORMING ALL CONDUIT SITE WORK, THEN A QUALIFIED ELECTRICIAN WILL BE REQUIRED TO BE ON SITE APPROVING THE CONDUIT INSTALLATION/ROUTING PRIOR TO COVERING THE CONDUITS.

ALL CONDUIT UNDERGROUND WORK SHALL COMPLY WITH THE GENERAL CONDITIONS BELOW:

COMPOSITION – THE CONDUITS SHALL BE CORROSION RESISTANT AND SHALL BE MADE OF EPC-80-PVC (SCHEDULE 80) IAW NEMA TC-2. THE CONDUITS SHALL BE APPROPRIATELY LABELED INDICATING THE COMPOSITION MATERIAL. CONDUITS SHALL HAVE A SLEEVE OR BELL END TYPE COUPLING AND SHALL BE WATERTIGHT WHEN ASSEMBLED.

INSTALLATION – INSTALLATION OF UNDERGROUND CONDUITS SHALL BE A MINIMUM OF 24" BELOW GRADE. INSTALL IN COMMONS TRENCH WHERE SHOWN ON THE CIVIL PLANS. IN MAINTENANCE HOLES WITH KNOCKOUTS, CONDUITS SHALL START AT THE BOTTOM KNOCKOUT, ALLOWING FOR UPWARD EXPANSION IN THE MAINTENANCE HOLES. THE CONTRACTOR SHALL PROVIDE OTHER PROTECTIVE MEASURES, CONCRETE CAP, ETC., IN THOSE AREAS WHERE THE MINIMUM GROUND COVER CANNOT BE ACHIEVED.

BENDS AND SEALING.

THE SUM OF BENDS IN ALL DIRECTIONS SHALL NOT EXCEED A TOTAL OF 180 DEGREES. CONDUITS SHALL HAVE BELL ENDS AND ENTER A MAINTENANCE HOLES PERPENDICULAR TO THE SURFACE OF THE WALL THROUGH WHICH IT IS ENTERING. ALL CONDUITS ENTERING MAINTENANCE HOLES MUST BE SEALED. UNIVERSAL CONDUIT PLUGS OR REMOVABLE PUTTY SEALANTS MAY BE USED. UPON COMPLETION OF CONDUIT SECTIONS, A TEST MANDREL 1/4" (6.4MM) SMALLER THAN THE INSIDE DIAMETER OF THE CONDUIT SHALL BE PULLED THROUGH TWO DIAGONALLY OPPOSITE CONDUITS TO ENSURE PROPER ALIGNMENT. IN ADDITION, ALL CONDUITS SHALL BE CLEARED OF LOOSE MATERIALS SUCH AS CONCRETE, MUD, DIRT, STONES, ETC.

PULL ROPE

ALL VACANT CONDUITS SHALL BE PROVIDED WITH A WATERPROOF CORROSION RESISTANT MULE TAPE FOR FUTURE CABLE INSTALLATION. THE PULL ROPE /MULE TAPE SHALL EXTEND INTO THE MAINTENANCE HOLE AND BE SECURED TO THE CABLE RACK OR PULLING IRON, ETC.

SPACERS AND TRACER WIRE

ALONG THE LENGTH OF THE CONDUIT RUN, IF THE CONDUITS ARE INSTALLED BY TRENCHING, SPACERS SHALL BE PLACED AT AN INTERVAL OF FOUR (4) SPACERS PER 20 FEET AND CABLE WARNING TAPE SHALL BE BURIED ONE (1) FOOT BELOW THE SURFACE AND SHALL FOLLOW THE DUCT ROUTE. THE TAPE SHALL BE A MINIMUM OF THREE INCHES WIDE AND ORANGE IN COLOR WITH THE APPROPRIATE WARNING MESSAGE. AT LEAST ONE CONDUIT SHALL HAVE TRACER WIRE OR BE OTHERWISE LOCATABLE FROM THE SURFACE.

UTILITY SEPARATION

COMMUNICATIONS CONDUITS AND CABLE SHALL MAINTAIN A MINIMUM SEPARATION OF 12 INCHES FROM ALL TRADES.

LIGHTING FIXTURE SCHEDULE

MARK	MANUFACTURER AND CATALOG No.	LAMPS		MOUNTING	REMARKS	EQUALS
		No.	TYPE			
PL	LITHONIA DSX2 LED 100C 700 40K T3M MVOLT RPA SF (FINISH) POLE: RTA 30 8E	1	LED	POLE ARM MOUNT 33' ABOVE GRADE	SINGLE-PIECE DIE-CAST ALUMINUM HOUSING, POWDER COAT FINISH, 4000K, UNIVERSAL VOLTAGE, PROVIDE WITH SNAP LP-250-11, ROUND TAPERED ALUMINUM POLE	GARDCO #ECF-1-3-215LA-641A-NW-UNV POLE: VALMONT #R290845805-D1
PL2	LITHONIA DSX2 LED 100C 700 40K T4M MVOLT RPA SF (FINISH) POLE: RTA 30 8E	1	LED	POLE ARM MOUNT 33' ABOVE GRADE	SINGLE-PIECE DIE-CAST ALUMINUM HOUSING, POWDER COAT FINISH, 4000K, UNIVERSAL VOLTAGE, PROVIDE TWO FIXTURES MOUNTED AT 180°, PROVIDE WITH SNAP LP-250-11, ROUND TAPERED ALUMINUM POLE.	GARDCO #ECF-2-4-215LA-641A-NW-UNV POLE: VALMONT #R290845805-D2

* ALL FINISHES AND FIXTURE COLOR TEMPERATURE SHALL BE DIRECTED BY ARCHITECT/OWNER PRIOR TO ORDERING FIXTURES
** EACH FIXTURE REQUIRES 0-10 VOLT DIMMING CAPABILITY



FLORIDA ARCHITECTS
LICENSE #AA0002730

648 Florida Avenue
Panama City, FL 32401
P 850/257-5400

Principal in Charge
David M Bagwell
Project Number:
4166-2
Date Issued:
5-7-2015
Drawn By:
D.C.
Checked By:
D.B.
Revisions:



BAGWELL ENGINEERING
216 E. Government St.
Pensacola, FL 32502
Phone: (850) 462-8040
FL Authorization No. 30167
FL PE No. 58251
Job Number: 15-019

ELECTRICAL LEGEND
GULF COAST STATE COLLEGE
PHASE 1 CAMPUS
IMPROVEMENTS

BID DOCUMENTS
Sheet Number

Copyright © 2015 BY FLORIDA ARCHITECTS, INC. ARCHITECT EXPRESSLY RESERVES HIS EXCLUSIVE COMMON LAW COPYRIGHT AND PROPERTY RIGHTS TO THESE DRAWINGS WHICH MAY NOT BE REPRODUCED, CHANGED OR COPIED IN ANY FORM OR MANNER, NOR ARE THEY TO BE ASSIGNED TO ANY PARTY WITHOUT THE ARCHITECT'S WRITTEN CONSENT.

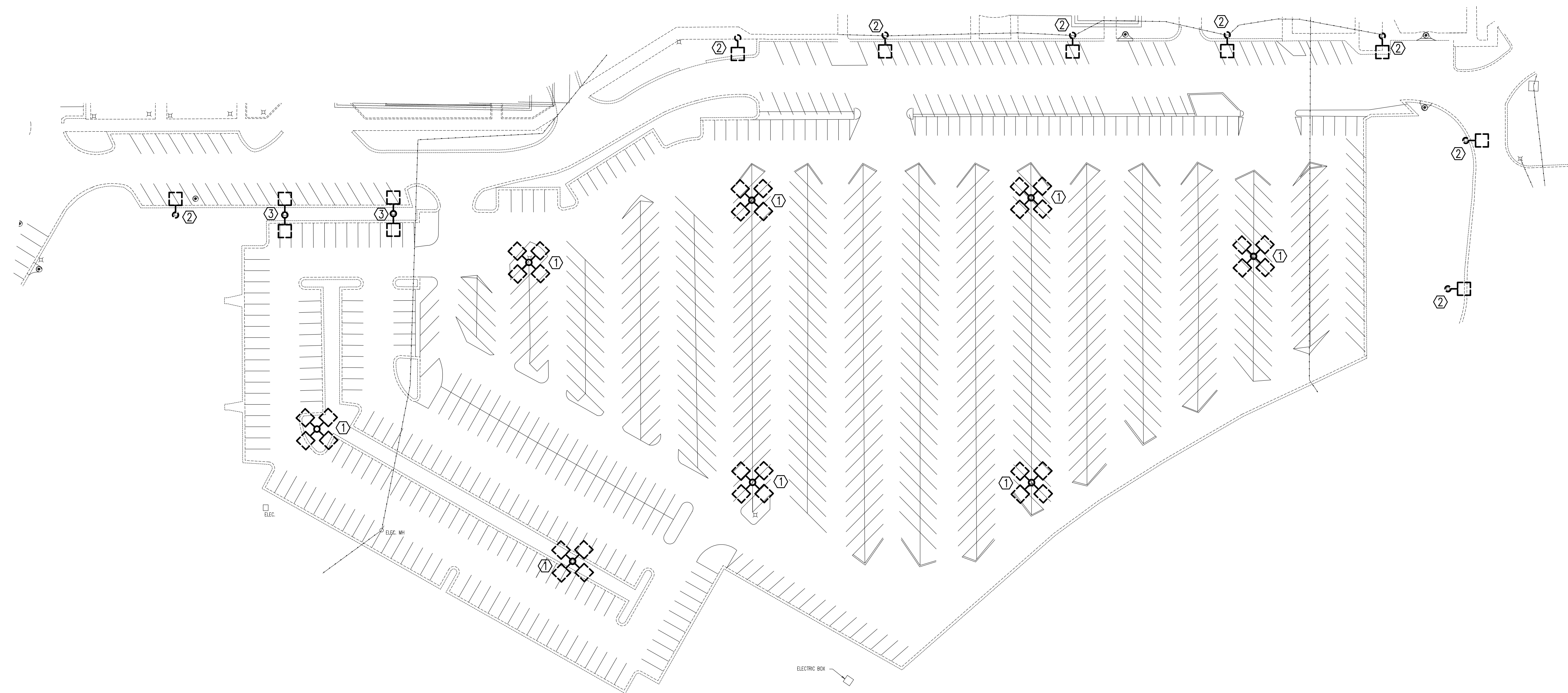

KEYNOTES:

- ① REMOVE EXISTING QUAD HEAD LIGHTING FIXTURE. REMOVE EXISTING CONCRETE BASE. REMOVE EXISTING CONDUCTORS BACK TO SOURCE. EXISTING CONDUITS SHALL BE CUT BELOW GRADE AND CAPPED AND ABANDONED IN PLACE.
- ② REMOVE EXISTING SINGLE HEAD LIGHTING FIXTURE. REMOVE EXISTING CONCRETE BASE. INFILL AND PATCH TO MATCH EXISTING. REMOVE EXISTING CONDUCTORS BACK TO SOURCE. EXISTING CONDUITS SHALL BE CUT BELOW GRADE AND CAPPED AND ABANDONED IN PLACE.
- ③ REMOVE EXISTING DUAL HEAD LIGHTING FIXTURE. REMOVE EXISTING CONCRETE BASE. INFILL AND PATCH TO MATCH EXISTING. REMOVE EXISTING CONDUCTORS BACK TO SOURCE. EXISTING CONDUITS SHALL BE CUT BELOW GRADE AND CAPPED AND ABANDONED IN PLACE.



PARKING LOT LIGHTING DEMOLITION PLAN

SCALE: 1" = 50'



FLORIDA ARCHITECTS
 LICENSE #AA0002730
 648 Florida Avenue
 Panama City, FL 32401
 P 850/257-5400

Principal in Charge
 David M Bagwell
 Project Number:
 4166-2
 Date Issued:
 5-7-2015
 Drawn By:
 D.C.
 Checked By:
 D.B.
 Revisions:



BAGWELL ENGINEERING
 216 E. Government St.
 Pensacola, FL 32502
 Phone: (850) 462-8040
 FL Authorization No. 30167
 FL PE No. 58251
 Job Number: 15-019

GULF COAST STATE COLLEGE
 PHASE 1 CAMPUS
 IMPROVEMENTS

ELECTRICAL
 DEMOLITION
 PLAN

BID DOCUMENTS

Sheet Number

E2

Copyright © 2015 by Florida Architects, Inc. All rights reserved. This drawing is the property of Florida Architects, Inc. and is not to be reproduced, changed or copied in any form or manner, nor are they to be assigned to any party without the architect's written consent.

EXISTING UTILITY LOCATION
 THE CONTRACTOR SHALL NOT BEGIN ANY DIGGING UNTIL THE EXISTING UTILITIES HAVE BEEN LOCATED AND FLAGGED BY THE COLLEGE. ALL WORK FROM EDGE OF PARKING LOT TO THE HANDHOLES AND NEAR BUILDINGS WILL REQUIRE HAND DIGGING.

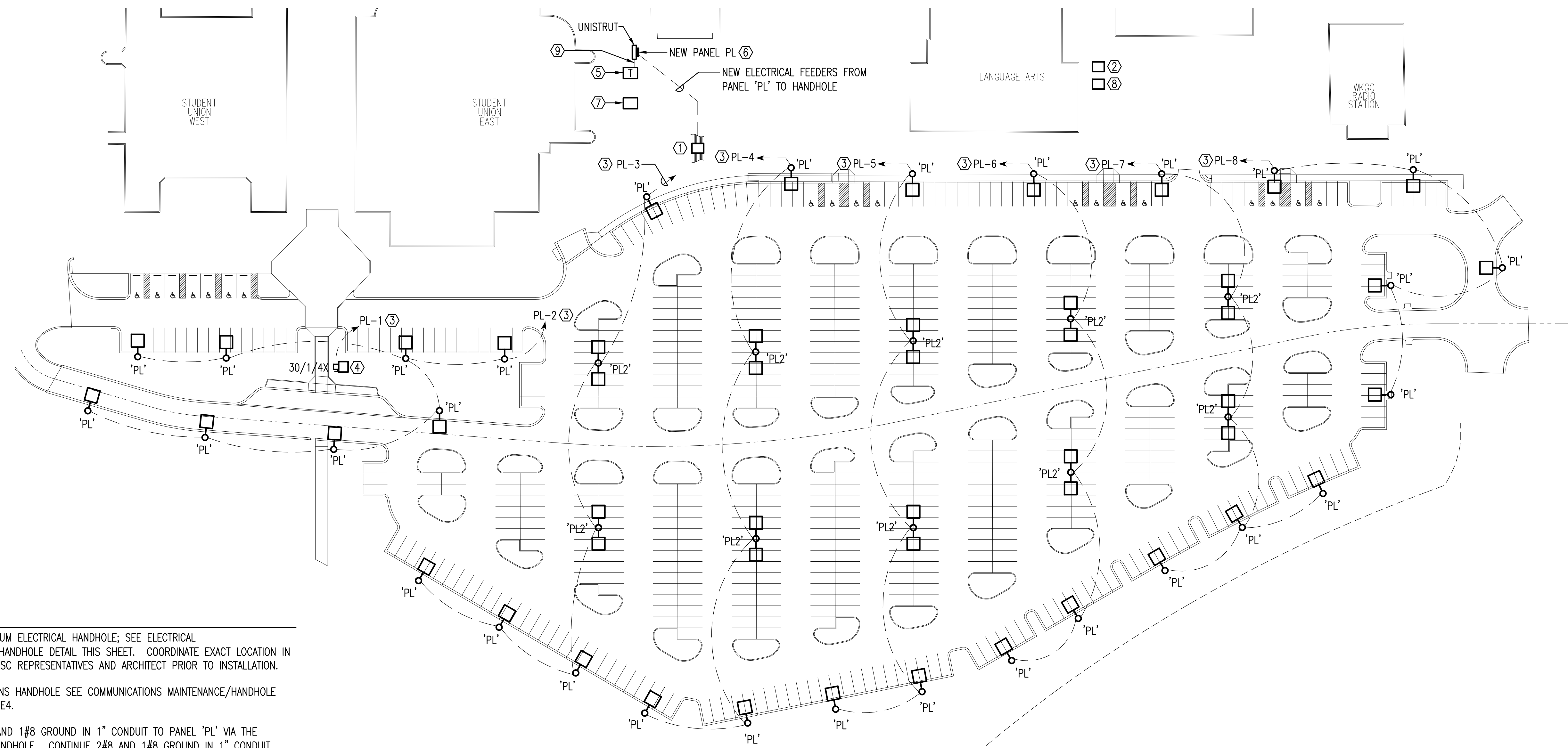

KEYNOTES:

- ① 24"x36" MINIMUM ELECTRICAL HANDHOLE; SEE ELECTRICAL MAINTENANCE/HANDHOLE DETAIL THIS SHEET. COORDINATE EXACT LOCATION IN FIELD WITH GCSC REPRESENTATIVES AND ARCHITECT PRIOR TO INSTALLATION.
- ② COMMUNICATIONS HANDHOLE SEE COMMUNICATIONS MAINTENANCE/HANDHOLE DETAIL SHEET E4.
- ③ INSTALL 2#8 AND 1#8 GROUND IN 1" CONDUIT TO PANEL 'PL' VIA THE ELECTRICAL HANDHOLE. CONTINUE 2#8 AND 1#8 GROUND IN 1" CONDUIT THROUGH THE END DEVICE OF THE CIRCUIT. WHERE POSSIBLE UTILIZE THE COMMON UTILITY TRENCH FOR ALL INSTALLATIONS THROUGH THE EXISTING PARKING AREA.
- ④ NEW ILLUMINATED SIGN/MAP LOCATION. COORDINATE EXACT LOCATION IN FIELD PRIOR TO INSTALLING CIRCUIT. INSTALL A 30/1/4X DISCONNECT AND CONNECT TO A NEW 277-120 VOLT TRANSFORMER IN WEATHERPROOF ENCLOSURE PRIOR TO CONNECTING CIRCUIT TO SIGN/MAP. CONNECT TO SIGN/MAP PER THE MANUFACTURERS REQUIREMENTS. COORDINATE THE LOCATIONS OF DISCONNECTS AND WEATHERPROOF ENCLOSURES WITH THE ARCHITECT PRIOR TO INSTALLING TO ENSURE AN AESTHETIC PRESENTATION.
- ⑤ EXISTING PAD MOUNT 277/480V, 3 PHASE TRANSFORMER TO REMAIN.
- ⑥ NEW 60 AMP 277V/3 PHASE PANEL 'PL' IN NEMA 4X ENCLOSURE. PANEL SHALL BE MOUNTED ON UNISTRUT. SEE PANEL MOUNTING DETAIL SHEET E6. LEVEL GRADE PRIOR TO INSTALLING PAD.
- ⑦ EXISTING ELECTRICAL JUNCTION CABINET TO REMAIN.
- ⑧ ELECTRICAL HANDHOLE FOR FUTURE CCTV 120 VOLT POWER. REFER TO SHEET E4 FOR ADDITIONAL INFORMATION. NO CONDUIT SHOWN ON THIS SHEET SHALL BE ROUTED TO THIS HANDHOLE. COORDINATE EXACT LOCATION IN FIELD WITH GCSC REPRESENTATIVES AND ARCHITECT PRIOR TO INSTALLATION.
- ⑨ NEW ELECTRICAL SECONDARY. REFER TO POWER RISER DIAGRAM SHEET E7 FOR WIRE AND CONDUIT SIZE.

NEW WORK PARKING LOT LIGHTING ELECTRICAL PLAN
 SCALE: 1" = 50'

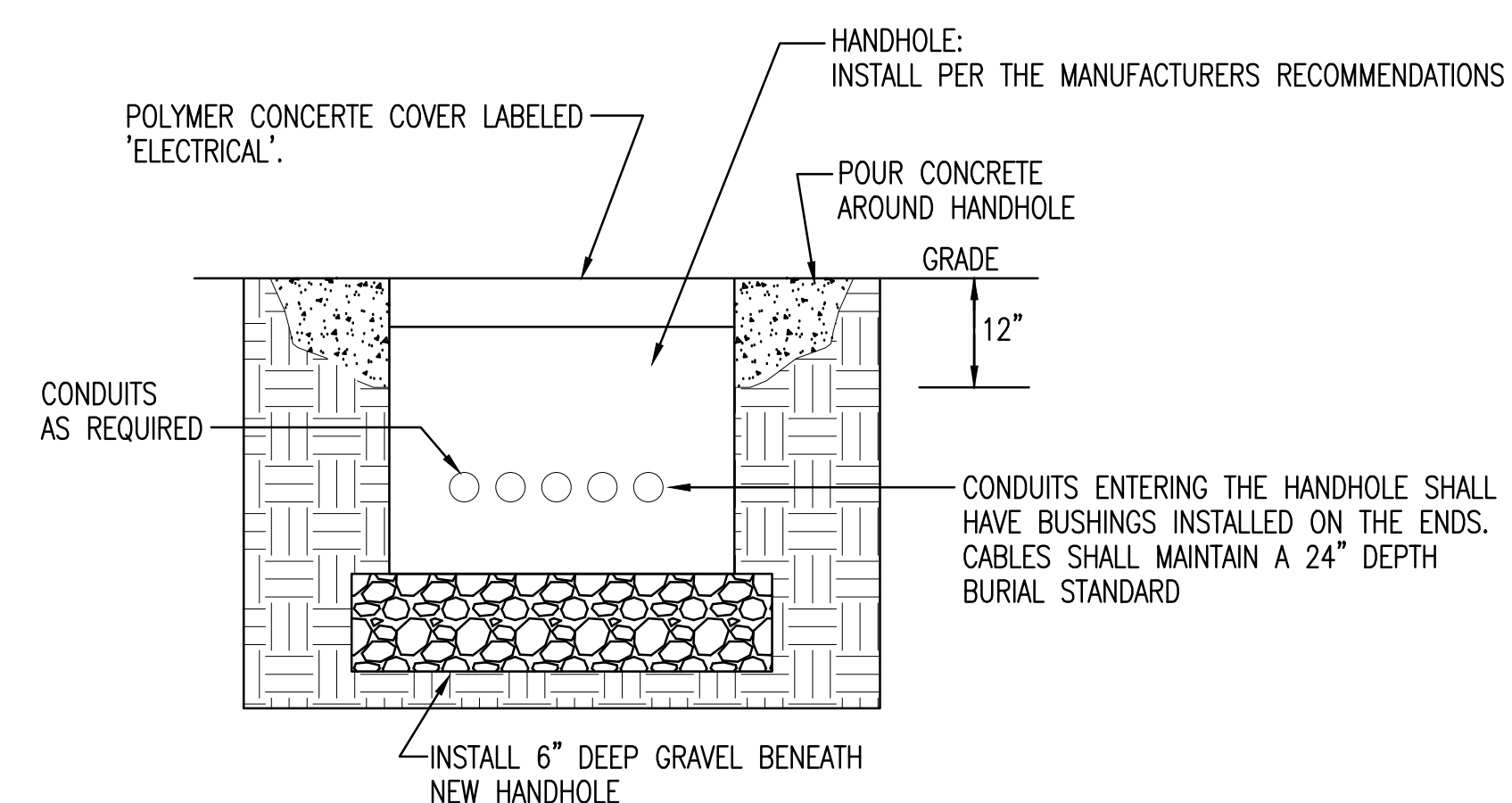

ELECTRICAL MAINTENANCE/HANDHOLE DETAIL
 NOT TO SCALE

HANDHOLE REQUIREMENTS:
 MAINTENANCE HOLES ARE REQUIRED TO MEET ANSI/SCTE 77 TIER 15. MAINTENANCE HOLES SHALL BE PRECAST CONCRETE. COVER SHALL MEET ENVIRONMENTAL CONDITIONS. EQUIP THE MAINTENANCE HOLE WITH CORROSION RESISTANT PULLING IRONS

POLE FOUNDATION NOTE:
 THE POLE FOUNDATION SHALL BE SQUARE ABOVE GRADE BUT ROTATED 45 DEGREES IN A "DIAMOND" SHAPE IN THE MIDDLE OF THE PARKING SPACE. COORDINATE EXACT ORIENTATION WITH THE ARCHITECT PRIOR TO THE FIRST FOUNDATION INSTALLATION.

CIRCUITING NOTE:
 THE CIRCUITING SHOWN IS DIAGRAMMATIC. CONDUIT AND WIRE SHALL BE INSTALLED IN COMMON TRENCHES WITH OTHER UTILITIES. COORDINATE WITH THE CIVIL PLAN FOR TRENCH DETAILS.

COPYRIGHT © 2015 BY FLORIDA ARCHITECTS, INC. ARCHITECT EXPRESSLY RESERVES HIS EXCLUSIVE COMMON LAW COPYRIGHT AND PROPERTY RIGHTS TO THESE DRAWINGS WHICH MAY NOT BE REPRODUCED, CHANGED OR COPIED IN ANY FORM OR MANNER, NOR ARE THEY TO BE ASSIGNED TO ANY PARTY WITHOUT THE ARCHITECT'S WRITTEN CONSENT.

EXISTING UTILITY LOCATION
 THE CONTRACTOR SHALL NOT BEGIN ANY DIGGING UNTIL THE EXISTING UTILITIES HAVE BEEN LOCATED AND FLAGGED BY THE COLLEGE. ALL WORK FROM EDGE OF PARKING LOT TO THE HANDHOLES AND NEAR BUILDINGS WILL REQUIRE HAND DIGGING.

REFER TO SHEET E5 FOR ENLARGED FLOOR PLAN

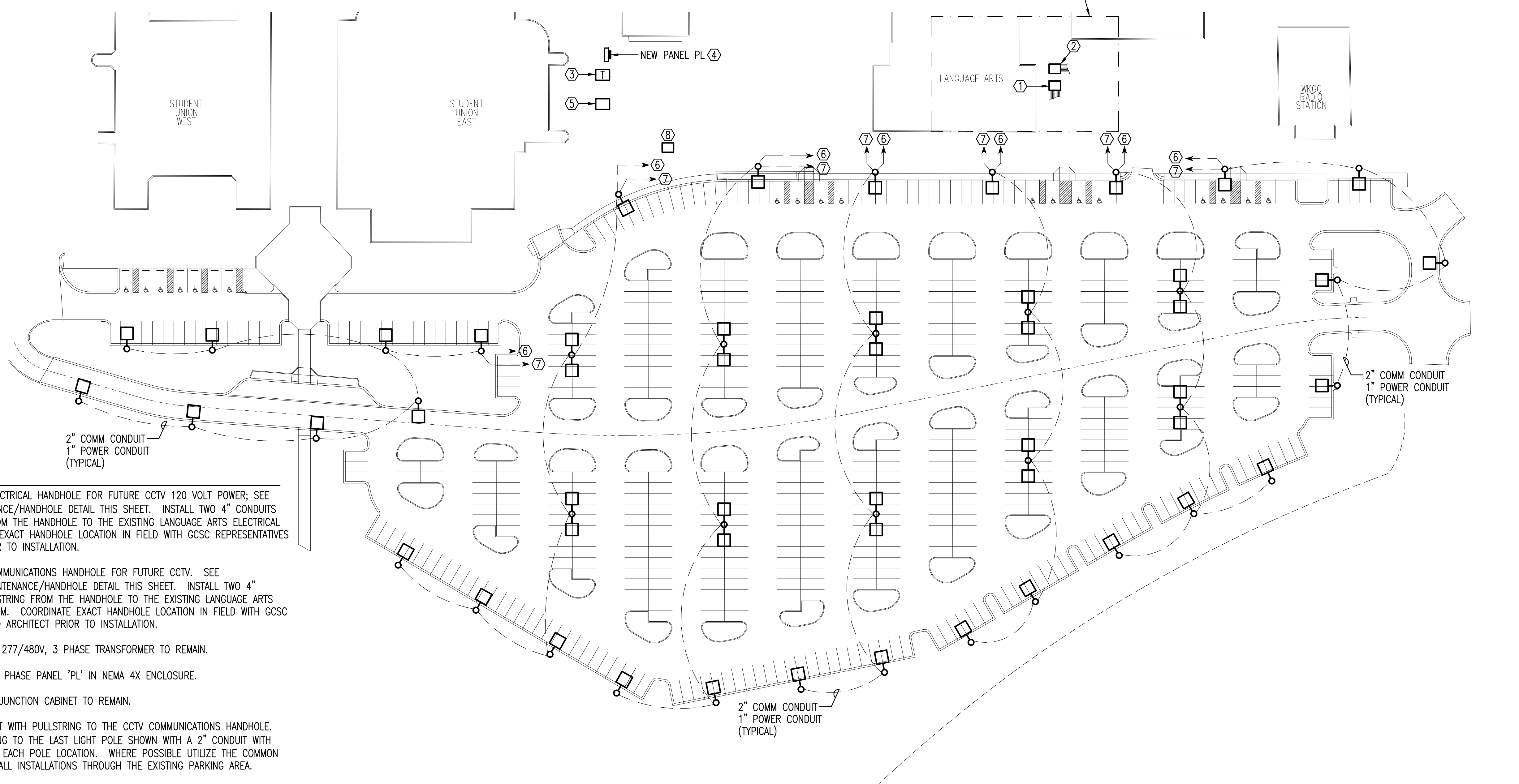

- KEYNOTES:**
- ① 24"x36" MINIMUM ELECTRICAL HANDHOLE FOR FUTURE CCTV 120 VOLT POWER; SEE ELECTRICAL MAINTENANCE/HANDHOLE DETAIL THIS SHEET. INSTALL TWO 4" CONDUITS WITH PULLSTRING FROM THE HANDHOLE TO THE EXISTING LANGUAGE ARTS ELECTRICAL ROOM. COORDINATE EXACT HANDHOLE LOCATION IN FIELD WITH GCSC REPRESENTATIVES AND ARCHITECT PRIOR TO INSTALLATION.
 - ② 24"x36" MINIMUM COMMUNICATIONS HANDHOLE FOR FUTURE CCTV. SEE COMMUNICATIONS MAINTENANCE/HANDHOLE DETAIL THIS SHEET. INSTALL TWO 4" CONDUITS WITH PULLSTRING FROM THE HANDHOLE TO THE EXISTING LANGUAGE ARTS COMMUNICATIONS ROOM. COORDINATE EXACT HANDHOLE LOCATION IN FIELD WITH GCSC REPRESENTATIVES AND ARCHITECT PRIOR TO INSTALLATION.
 - ③ EXISTING PAD MOUNT 277/480V, 3 PHASE TRANSFORMER TO REMAIN.
 - ④ NEW 60 AMP 277V/3 PHASE PANEL 'PL' IN NEMA 4X ENCLOSURE.
 - ⑤ EXISTING ELECTRICAL JUNCTION CABINET TO REMAIN.
 - ⑥ INSTALL A 2" CONDUIT WITH PULLSTRING TO THE CCTV COMMUNICATIONS HANDHOLE. CONTINUE THE ROUTING TO THE LAST LIGHT POLE SHOWN WITH A 2" CONDUIT WITH PULLSTRING BETWEEN EACH POLE LOCATION. WHERE POSSIBLE UTILIZE THE COMMON UTILITY TRENCH FOR ALL INSTALLATIONS THROUGH THE EXISTING PARKING AREA.
 - ⑦ INSTALL A 1" CONDUIT WITH PULLSTRING TO THE CCTV ELECTRICAL HANDHOLE. CONTINUE THE ROUTING TO THE LAST LIGHT POLE SHOWN WITH A 1" CONDUIT WITH PULLSTRING BETWEEN EACH POLE LOCATION. WHERE POSSIBLE UTILIZE THE COMMON UTILITY TRENCH FOR ALL INSTALLATIONS THROUGH THE EXISTING PARKING AREA.
 - ⑧ ELECTRICAL HANDHOLE FOR LIGHT POLE CIRCUITING. REFER TO SHEET E3 FOR ADDITIONAL INFORMATION. NO CONDUIT SHOWN ON THIS SHEET SHALL BE ROUTED TO THIS HANDHOLE.

NEW WORK PARKING LOT CCTV INFRASTRUCTURE PLAN
 SCALE: 1" = 50'

HANDHOLE REQUIREMENTS:
 MAINTENANCE HOLES ARE REQUIRED TO MEET ANSI/SCTE 77 TIER 15. MAINTENANCE HOLES SHALL BE PRECAST CONCRETE. COVER SHALL MEET ENVIRONMENTAL CONDITIONS. EQUIP THE MAINTENANCE HOLE WITH CORROSION RESISTANT PULLING IRONS

CIRCUITING/ROUTING NOTE:
 THE CONDUIT ROUTING SHOWN IS DIAGRAMMATIC. CONDUIT SHALL BE INSTALLED IN COMMON TRENCHES WITH OTHER UTILITIES. COORDINATE WITH THE CIVIL PLAN FOR TRENCH DETAILS.

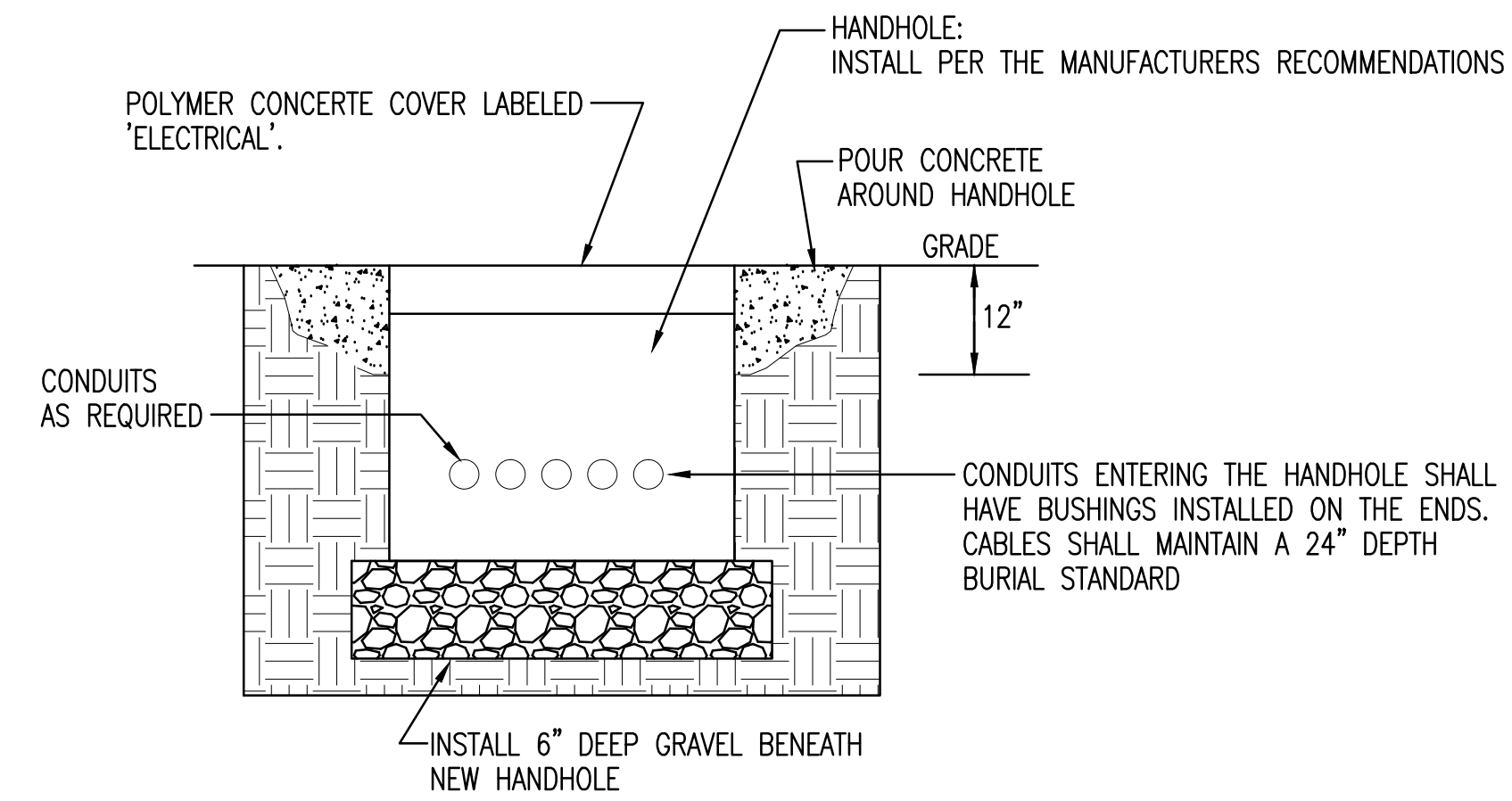
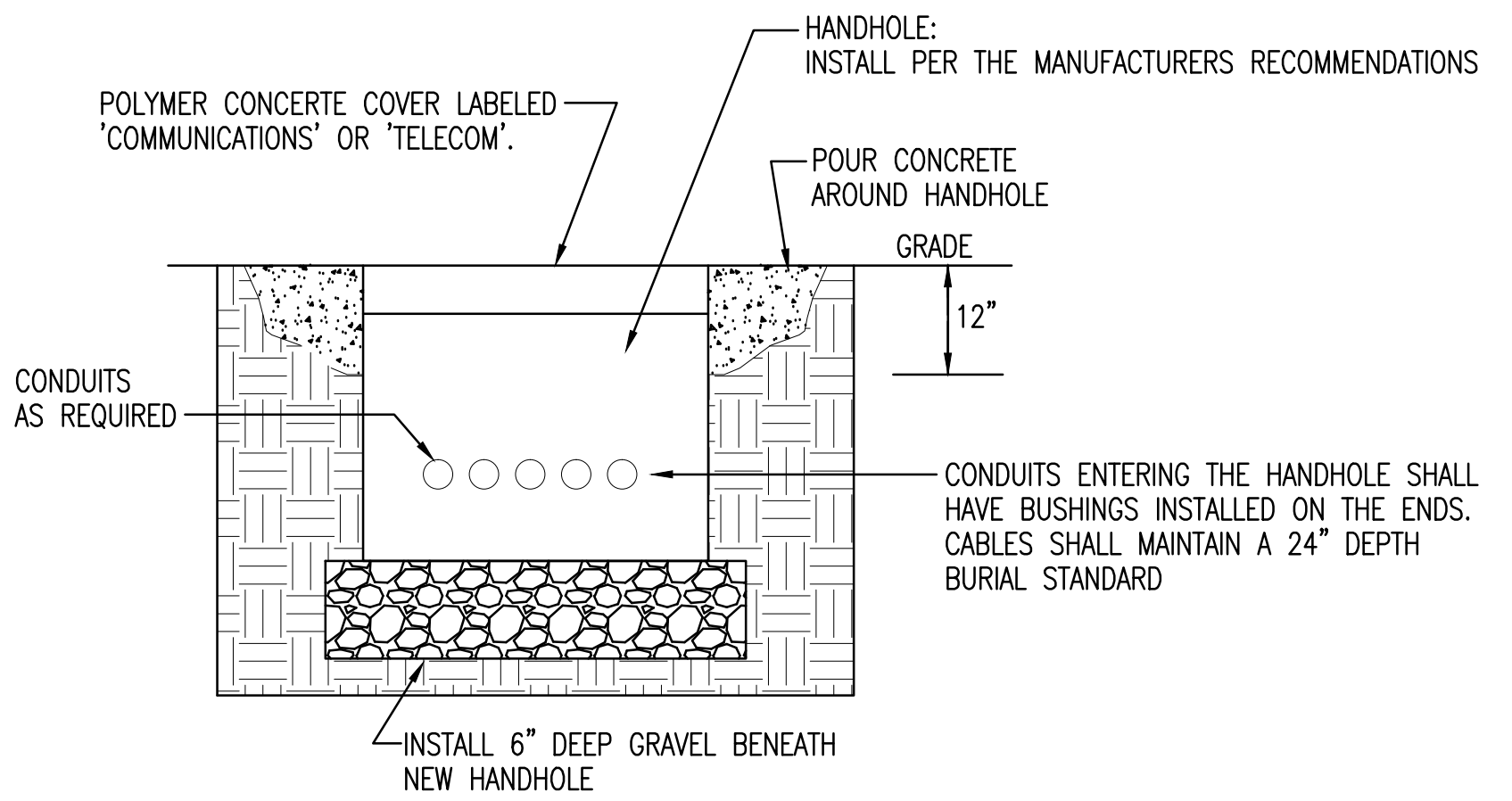

Copyright © 2015 BY FLORIDA ARCHITECTS, INC. ARCHITECT EXPRESSLY RESERVES HIS EXCLUSIVE COMMON LAW COPYRIGHT AND PROPERTY RIGHTS TO THESE DRAWINGS WHICH MAY NOT BE REPRODUCED, CHANGED OR COPIED IN ANY FORM OR MANNER, NOR ARE THEY TO BE ASSIGNED TO ANY PARTY WITHOUT THE ARCHITECT'S WRITTEN CONSENT.

Copyright © 2015 by Florida Architects, Inc. All rights reserved. This drawing is the property of Florida Architects, Inc. and shall not be reproduced, changed or copied in any form or manner, nor are they to be assigned to any party without the architect's written consent.

INTERIOR CEILING NOTE:
 THE CONTRACTOR SHALL TAKE CARE OF REMOVING/STORING CEILING TILES AND INSTALLING NEW CONDUITS. CEILING TILES WILL BE REPLACED IF DAMAGED OR STAINED DURING CONSTRUCTION.

EXISTING UTILITY LOCATION
 THE CONTRACTOR SHALL NOT BEGIN ANY DIGGING UNTIL THE EXISTING UTILITIES HAVE BEEN LOCATED AND FLAGGED BY THE COLLEGE. ALL WORK FROM EDGE OF PARKING LOT TO THE HANDHOLES AND NEAR BUILDINGS WILL REQUIRE HAND DIGGING.

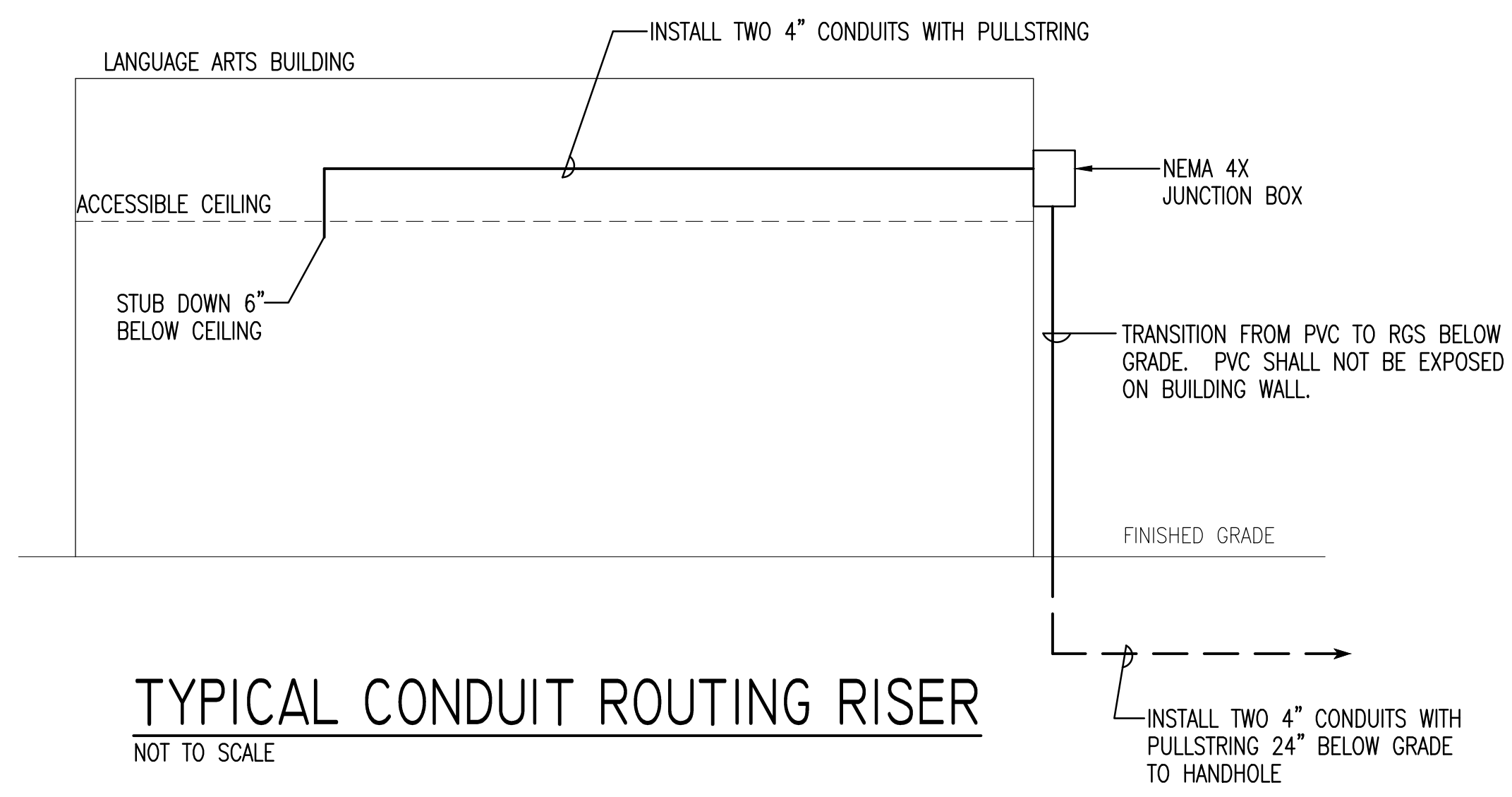

TYPICAL CONDUIT ROUTING RISER
 NOT TO SCALE

KEYNOTES:

- ① 24"x36" MINIMUM ELECTRICAL HANDHOLE FOR FUTURE CCTV 120 VOLT POWER. INSTALL TWO 4" CONDUITS WITH PULLSTRING FROM THE HANDHOLE TO THE EXISTING LANGUAGE ARTS ELECTRICAL ROOM. COORDINATE EXACT HANDHOLE LOCATION IN FIELD WITH GCSC REPRESENTATIVES AND ARCHITECT PRIOR TO INSTALLATION.
- ② 24"x36" MINIMUM COMMUNICATIONS HANDHOLE FOR FUTURE CCTV. INSTALL TWO 4" CONDUITS WITH PULLSTRING FROM THE HANDHOLE TO THE EXISTING LANGUAGE ARTS COMMUNICATIONS ROOM. COORDINATE EXACT HANDHOLE LOCATION IN FIELD WITH GCSC REPRESENTATIVES AND ARCHITECT PRIOR TO INSTALLATION.
- ③ INSTALL A 18"x18"x8" DEEP NEMA 4X JUNCTION BOX APPROXIMATELY 8" ABOVE GRADE. COORDINATE EXACT MOUNTING HEIGHT WITH GCSC PRIOR TO INSTALLING.
- ④ INSTALL TWO 4" CONDUITS WITH PULLSTRING TO THE EXISTING COMMUNICATIONS ROOM. STUB 6" INTO ROOM PER THE GCSC REPRESENTATIVES DIRECTION.
- ⑤ INSTALL TWO 4" CONDUITS WITH PULLSTRING TO THE EXISTING ELECTRICAL ROOM. STUB 6" INTO ROOM PER THE GCSC REPRESENTATIVES DIRECTION.
- ⑥ INSTALL TWO 4" CONDUITS WITH PULLSTRING FROM THE HANDHOLE TO THE NEW NEMA JUNCTION BOX. CONDUIT SHALL BE RGS WHERE EXPOSED.
- ⑦ NEW LIGHTING CONTROL SYSTEM ANTENNA; MOUNTING HEIGHT SHALL BE COORDINATED WITH GCSC. ANTENNA IS REQUIRED TO HAVE LINE OF SIGHT TO A MINIMUM OF TWO NEW LIGHTING POLES. INSTALL ASSEMBLY PER THE MANUFACTURERS REQUIREMENTS.

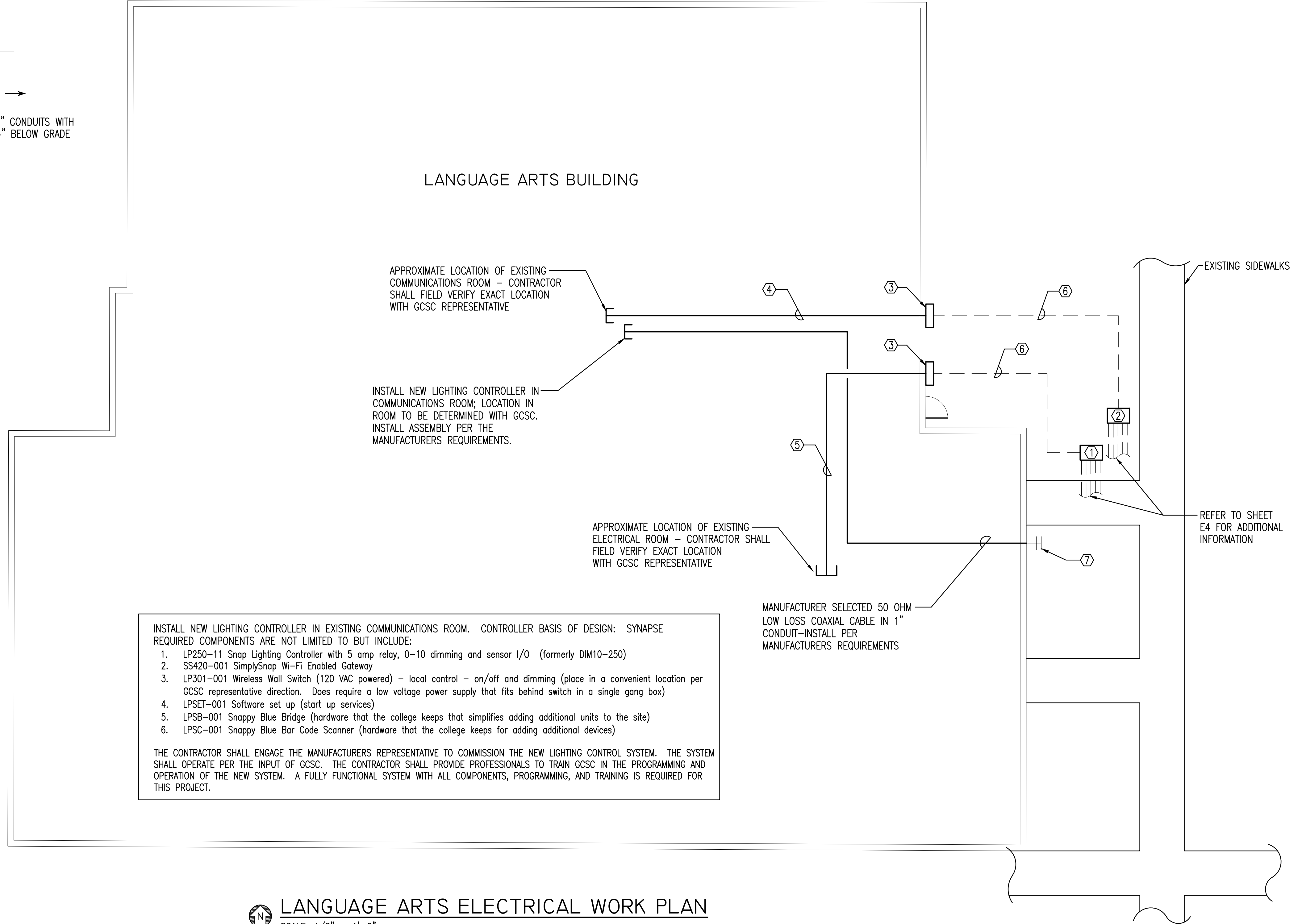

INSTALL NEW LIGHTING CONTROLLER IN EXISTING COMMUNICATIONS ROOM. CONTROLLER BASIS OF DESIGN: SYNAPSE
 REQUIRED COMPONENTS ARE NOT LIMITED TO BUT INCLUDE:

1. LP250-11 Snap Lighting Controller with 5 amp relay, 0-10 dimming and sensor I/O (formerly DIM10-250)
2. SS420-001 SimplySnap Wi-Fi Enabled Gateway
3. LP301-001 Wireless Wall Switch (120 VAC powered) - local control - on/off and dimming (place in a convenient location per GCSC representative direction. Does require a low voltage power supply that fits behind switch in a single gang box)
4. LPSET-001 Software set up (start up services)
5. LPSB-001 Snappy Blue Bridge (hardware that the college keeps that simplifies adding additional units to the site)
6. LPSC-001 Snappy Blue Bar Code Scanner (hardware that the college keeps for adding additional devices)

THE CONTRACTOR SHALL ENGAGE THE MANUFACTURERS REPRESENTATIVE TO COMMISSION THE NEW LIGHTING CONTROL SYSTEM. THE SYSTEM SHALL OPERATE PER THE INPUT OF GCSC. THE CONTRACTOR SHALL PROVIDE PROFESSIONALS TO TRAIN GCSC IN THE PROGRAMMING AND OPERATION OF THE NEW SYSTEM. A FULLY FUNCTIONAL SYSTEM WITH ALL COMPONENTS, PROGRAMMING, AND TRAINING IS REQUIRED FOR THIS PROJECT.

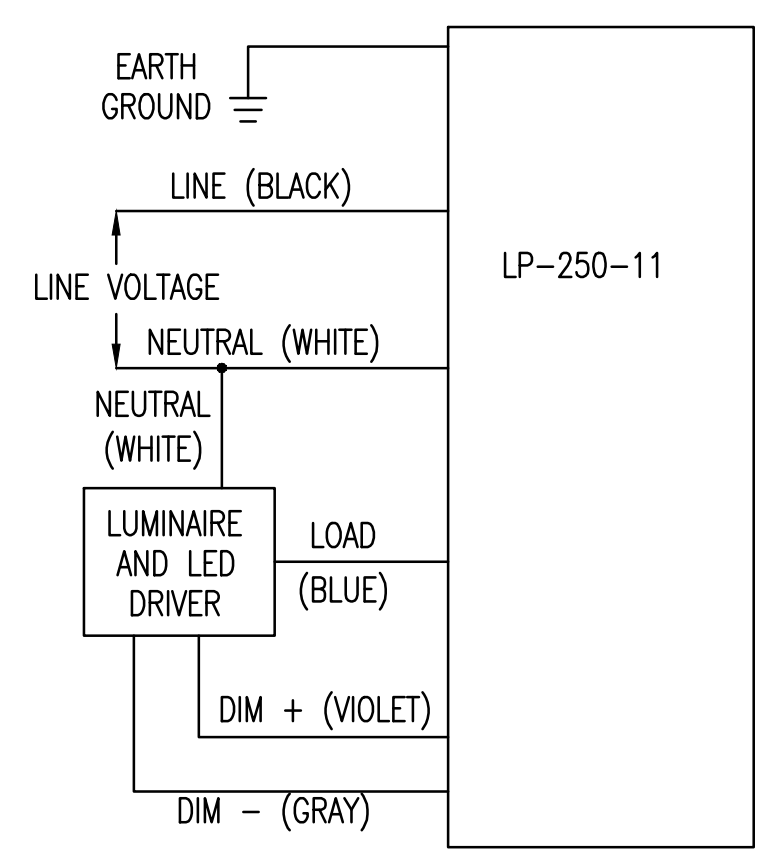

NOTE: THE DIAGRAM IS A TYPICAL SETUP PER THE MANUFACTURER TO HELP WITH BIDDING PURPOSES. THE CONTRACTOR WILL INSTALL ALL NEW DEVICES PER THE MANUFACTURERS INSTRUCTIONS.

LP-250-11 WIRING DIAGRAM
 NOT TO SCALE

LANGUAGE ARTS ELECTRICAL WORK PLAN
 SCALE: 1/8" = 1'-0"

Copyright © 2015 by Florida Architects, Inc. All rights reserved. This drawing is the property of Florida Architects, Inc. and is not to be reproduced, changed or copied in any form or manner, nor are they to be assigned to any party without the architect's written consent.

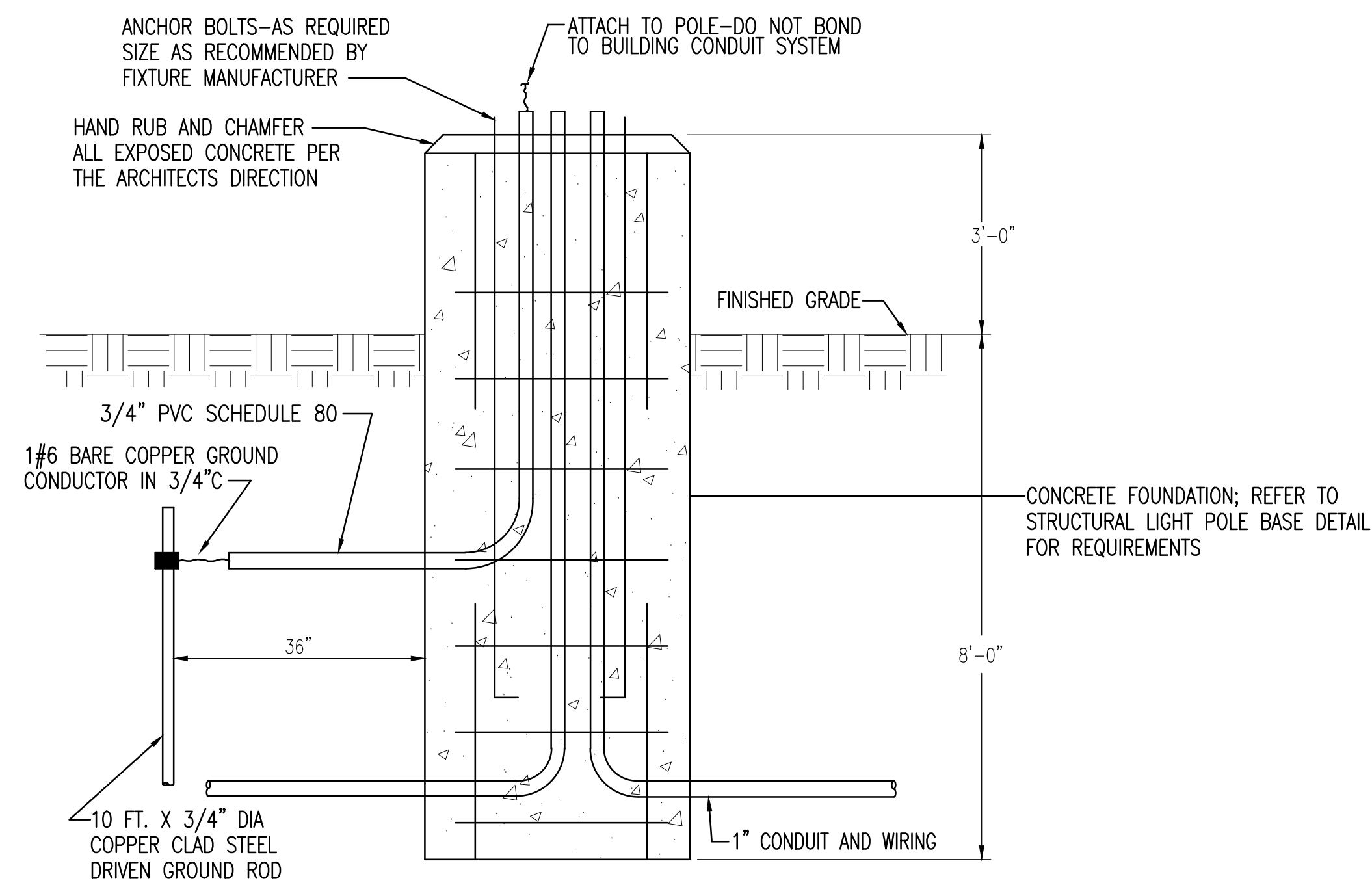

ELECTRICAL POLE BASE FOR FIXTURES 'PL', 'PL2',
 NOT TO SCALE

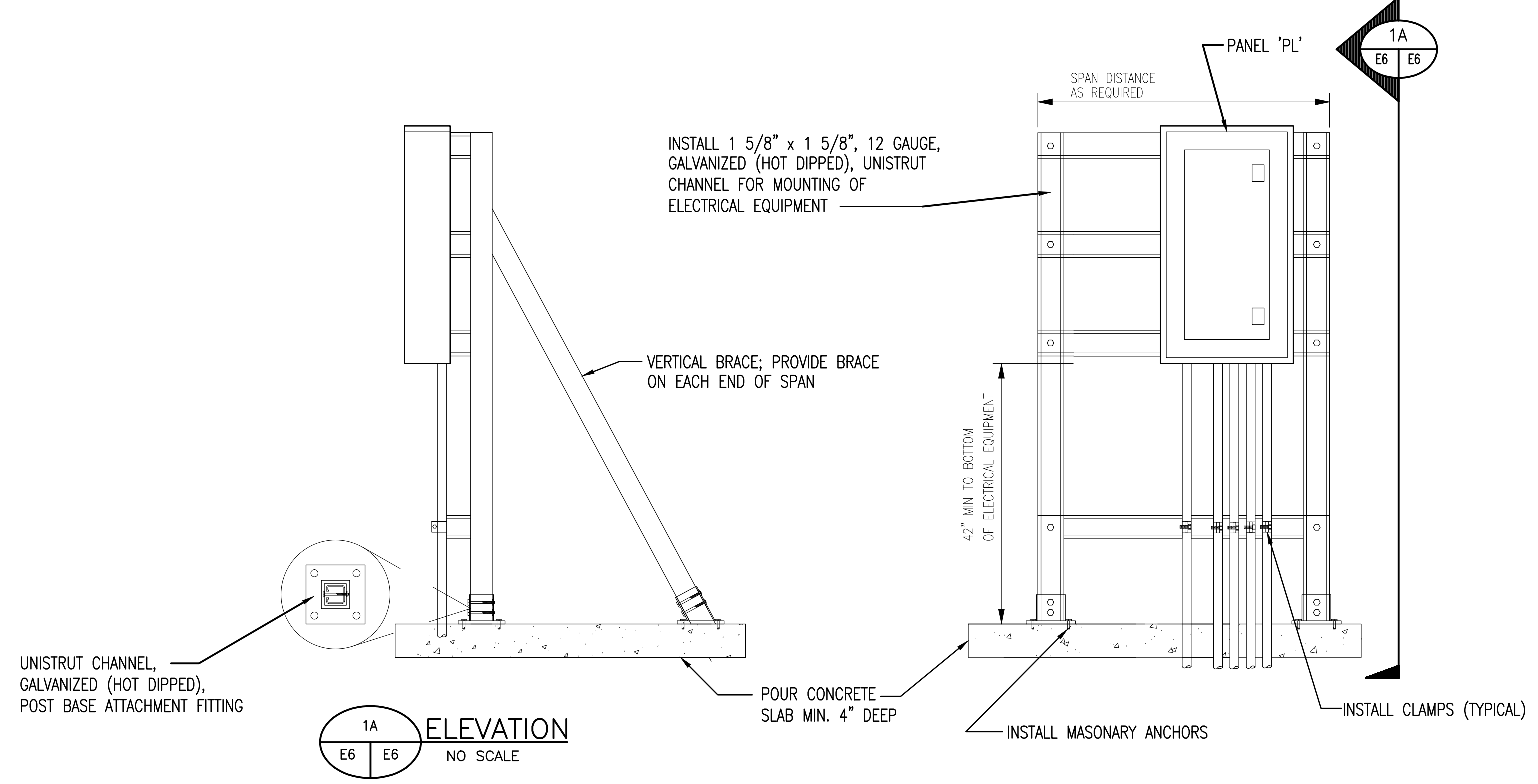

PANEL MOUNTING DETAIL
 NOT TO SCALE

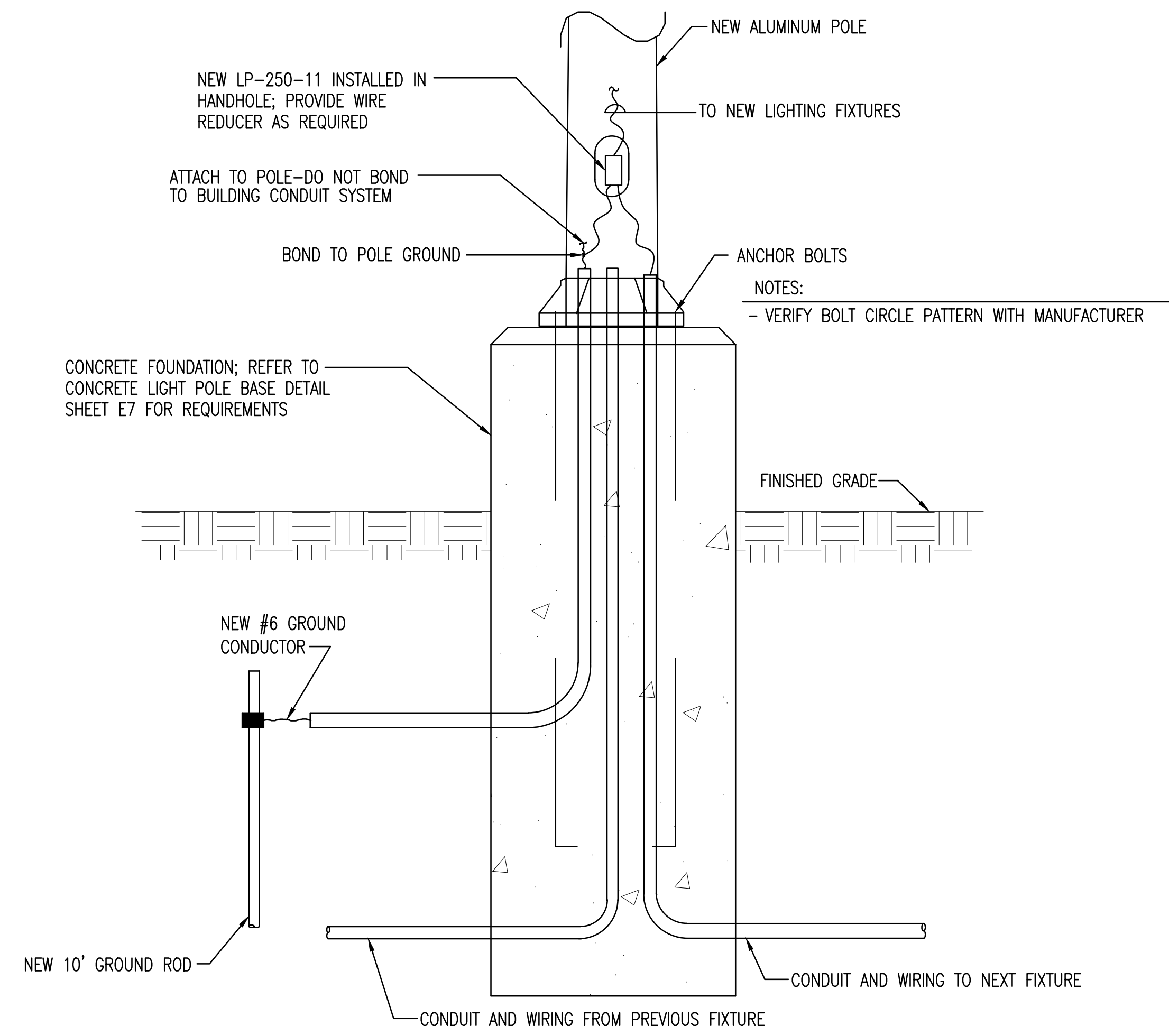

POLE INSTALLATION DETAIL
 NOT TO SCALE

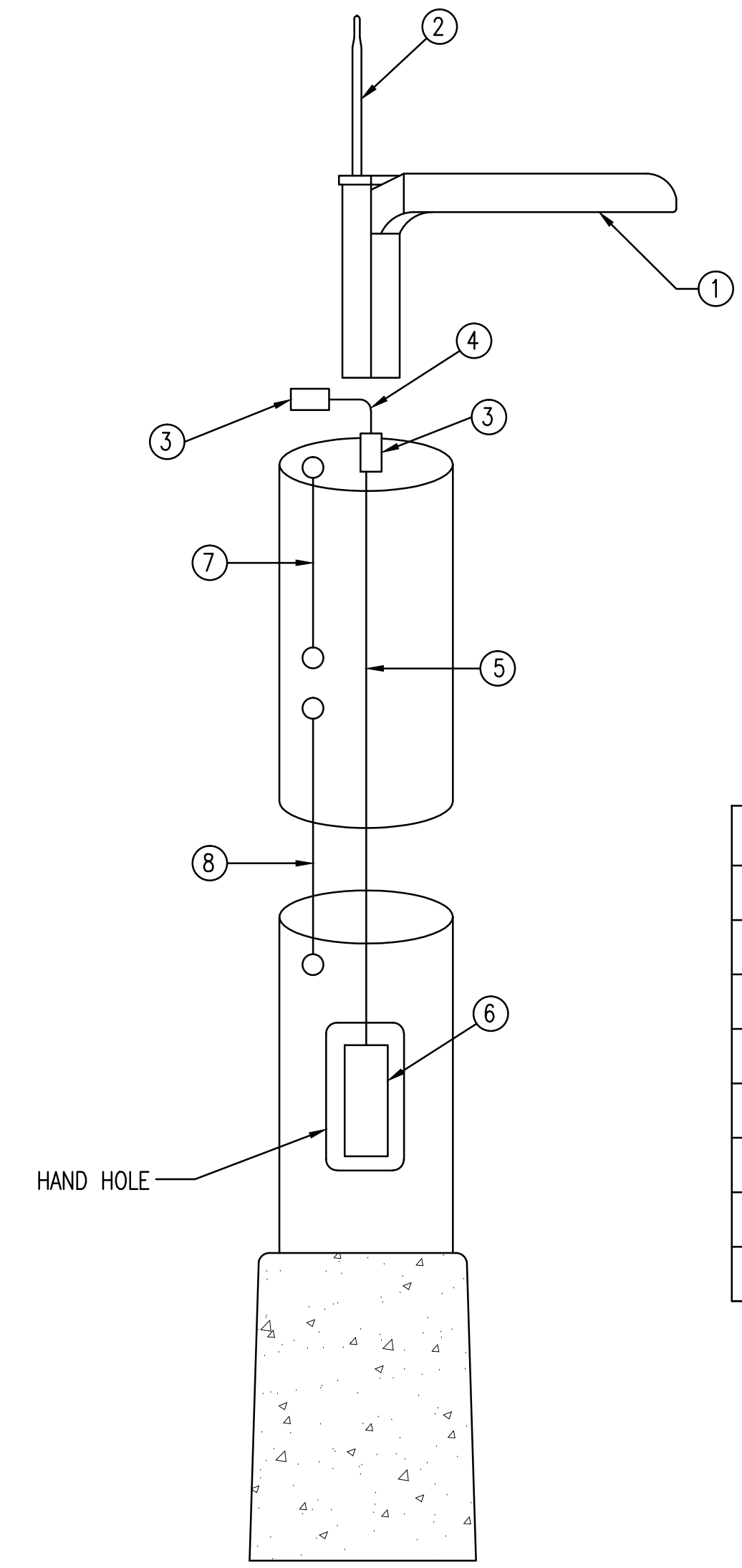

LP-250-II MOUNTING IN HAND HOLE WITH 30 FOOT POLE
 NOT TO SCALE

ITEM #	PART #	DESCRIPTION
①	LITHONIA DSX2 LED	LITHONIA DSX2 LED FIXTURE; SEE LIGHTING FIXTURE SCHEDULE FOR EXACT FIXTURE
②	HC2405RD-RSP	5 dBi RP-SMA ANTENNA L-COM
③	AXA-RSRSJB	BULKHEAD JACK - RP-SMA FEMALE TO RP-SMA FEMALE L-COM
④	CA-RSPRSPCN19	19" PIGTAIL CABLE - RP-SMA MALE TO RP-SMA L-COM
⑤	CA-RSPRSJA030	30 FOOT LOW LOSS RF CABLE L-COM ITEM
⑥	LP-250-11	250-11 LIGHT CONTROLLER SYNAPSE
⑦	DWYH08020	20 FOOT WIRE GRABBER - DUAL HOOKS - ARLINGTON
⑧	DWYH08010	10 FOOT WIRE GRABBER - DUAL HOOKS - ARLINGTON

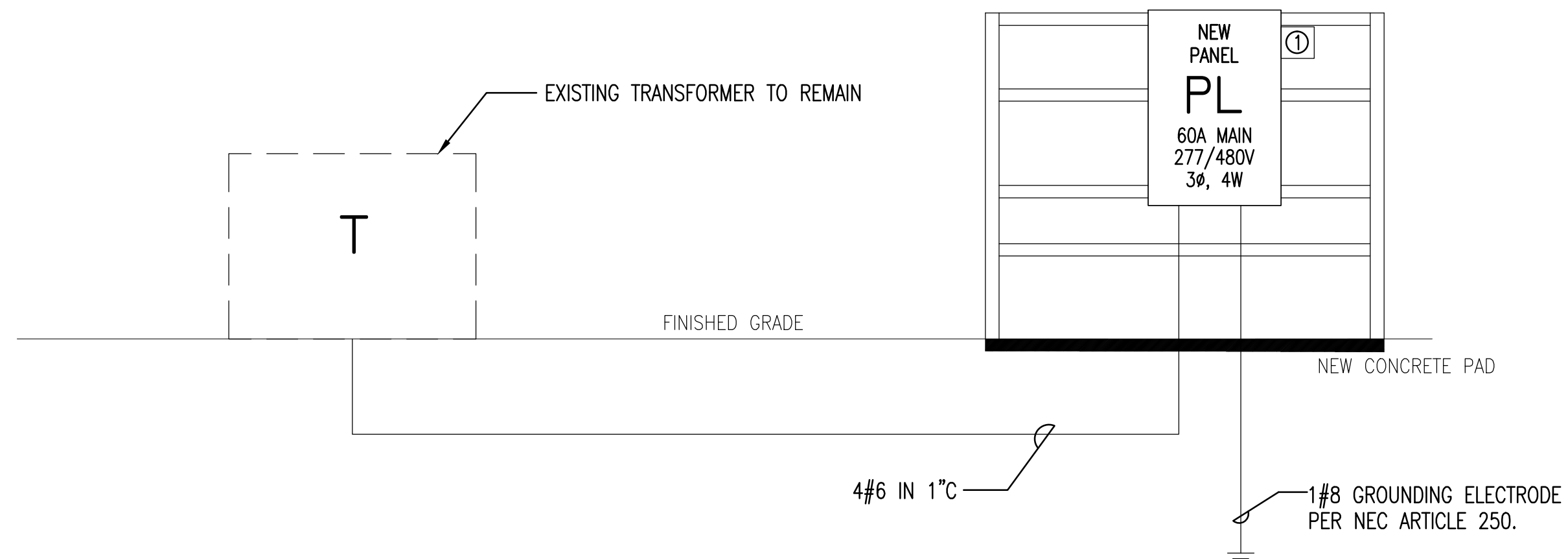

POWER RISER DIAGRAM

NOT TO SCALE

POWER RISER KEYNOTES:

- ① SURGE SUPPRESSOR; EQUAL TO SURGE SUPPRESSION INC. #SKB3Y2D3
INSTALL PER MANUFACTURER'S RECOMMENDATIONS; SURGE SUPPRESSOR SHALL BE NEMA 3R RATED.

277/480 VOLT 3φ 4W 60 AMP MAIN BREAKER PANEL SHALL BE SERVICE ENTRANCE RATED												UNISTRUT MOUNTED NEMA 4X ENCLOSURE		
CIRCUIT BREAKER PANEL SCHEDULE PANEL PL														
CKT	LOAD DESCRIPTION	BREAKER			KVA/PHASE			KVA/PHASE			BREAKER		LOAD DESCRIPTION	CKT
		POLE	AMP		A	B	C	A	B	C	AMP	POLE		
1	ILLUMINATED MAP	1	20		.1			1.16			20	1	PARKING LOT LIGHTS	2
3	PARKING LOT LIGHTS	1	20			2.55				1.62	20	1	PARKING LOT LIGHTS	4
5	PARKING LOT LIGHTS	1	20				1.62				20	1	PARKING LOT LIGHTS	6
7	PARKING LOT LIGHTS	1	20	1.86				1.16			20	1	PARKING LOT LIGHTS	8
9	SPARE	1	20								20	1	SPARE	10
11	SPARE	1	20								20	1	SPARE	12
13	SPARE	1	20								20	1	SPARE	14
15	SPARE	1	20								20	1	SPARE	16
17	SPACE ONLY	1	--								--	1	SPACE ONLY	18
19	SPACE ONLY	1	--								--	1	SPACE ONLY	20
21	SPACE ONLY	1	--								--	1	SPACE ONLY	22
23	SPACE ONLY	1	--								--	1	SPACE ONLY	24
25	SPACE ONLY	1	--								↓	↓	↓	26
27	SPACE ONLY	1	--								30	3	SURGE SUPPRESSOR	28
29	SPACE ONLY	1	--								↓	↓	↓	30

TOTAL CONNECTED KVA 4.28 4.17 3.24

MINIMUM INTERRUPTING CAPACITY: 22,000 AMPS SYMMETRICAL

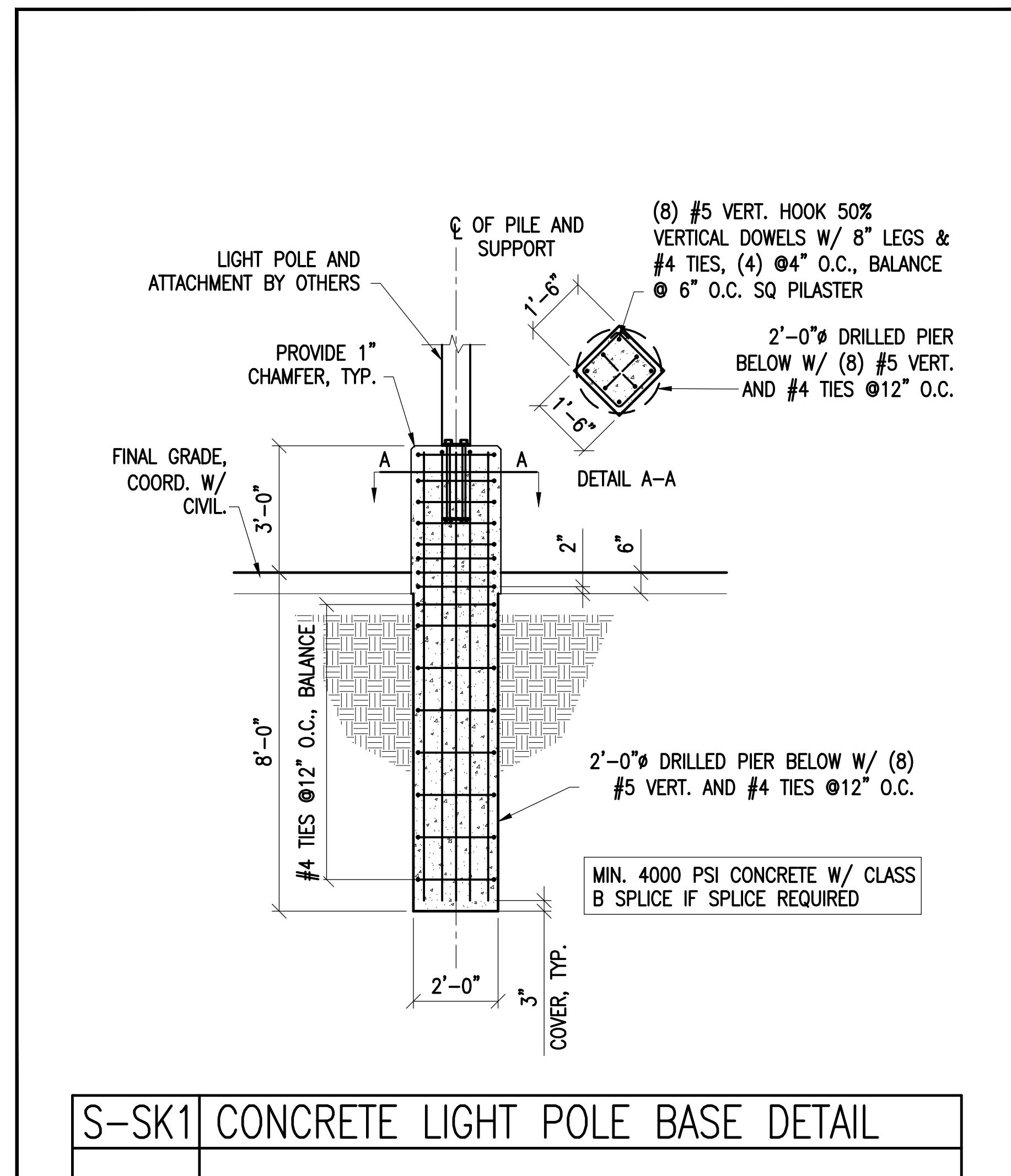

S-SK1 CONCRETE LIGHT POLE BASE DETAIL

<p>M'CARTHY ENGINEERING INC. FLORIDA CA LICENSE NUMBER #29241 216 E. GOVERNMENT ST. PENSACOLA, FLORIDA 32502 P. (850) 475-1288 F. (850) 502-4210</p>	GULF COAST STATE COLLEGE CONCRETE POLE BASE DETAIL		DATE 2015-05-03 2015-100
			DESIGNED DJM
			DRAWN WEM
			APPROVED DJM



FLORIDA ARCHITECTS
LICENSE #A00002730
648 Florida Avenue
Panama City, FL 32401
P 850/257-5400

Principal in Charge
David M Bagwell
Project Number:
4166-2
Date Issued:
5-7-2015
Drawn By:
D.C.
Checked By:
D.B.
Revisions:



BAGWELL ENGINEERING
216 E. Government St.
Pensacola, FL 32502
Phone: (850) 462-8040
FL Authorization No. 30167
FL PE No. 58251
Job Number: 15-019

ELECTRICAL RISER AND CONCRETE POLE FOUNDATION DETAIL
GULF COAST STATE COLLEGE
PHASE 1 CAMPUS IMPROVEMENTS

BID DOCUMENTS
Sheet Number

E7

Copyright © 2015 BY FLORIDA ARCHITECTS, INC. ARCHITECT EXPRESSLY RESERVES HIS EXCLUSIVE COPYRIGHT AND PROPERTY RIGHTS TO THESE DRAWINGS WHICH MAY NOT BE REPRODUCED, CHANGED OR COPIED IN ANY FORM OR MANNER, NOR ARE THEY TO BE ASSIGNED TO ANY PARTY WITHOUT THE ARCHITECT'S WRITTEN CONSENT.